

TECHNICAL MANUAL

**OPERATOR, ORGANIZATIONAL, DIRECT SUPPORT AND
GENERAL SUPPORT MAINTENANCE MANUAL**

SPRAYER, INSECTICIDE, AIRCRAFT-MOUNTED: WITH PUMP

AGRINAUTICS MODEL NO. 30000

FSN 3740-470-9811

**This reprint includes all changes in effect at the time
of publication; change 1**

**HEADQUARTERS, DEPARTMENT OF THE ARMY
21 DECEMBER 1971**

WARNING

In-flight checkout of the spray system must be carried out in an area set aside for this purpose to prevent accidental injury or contamination to personnel, animals, or vegetation. Never exceed an air speed of 120 knots with the spray system installed in the aircraft.

If spray booms vibrate or misalign during flight, reduce speed slowly, land, and adjust tension of cables. If a leak develops in flight within the sprayer system, apply pump brake at once and stop spraying. If fan blade is damaged in flight and causes vibration, apply pump brake at once and stop spraying.

WARNING

Avoid splashing insecticide fluid onto skin or into eyes. Observe precautions for handling poisonous fluids by flushing exposed areas with clean running water. Wash hands thoroughly with soap and water after handling and before eating or smoking.

WARNING

Fuel and fuel vapors are explosive mixtures. Do not use near open flame. Wash hands after using, before smoking or eating.

WARNING

Use cleaning solvent in well ventilated area. Avoid breathing of fumes and excessive contact with skin. Keep away from open flame. Wash hands before eating or smoking.

SAFETY PRECAUTIONS AND EMERGENCY PROCEDURES

A. Insecticide Sprayer

- (1) Never exceed air speed of 120 knots.
- (2) If booms noticeably vibrate or misalign during flight, reduce speed gradually, land and adjust tension of cables.
- (3) If a leak develops in flight within the aircraft, apply pump brake immediately and discontinue operation.
- (4) If fan blade becomes damaged in flight and causes vibration, apply pump brake immediately and discontinue operation.
- (5) If spray does not stop when valve control has been actuated, apply pump brake as an alternate method of control.
- (6) Do not attempt to lift by booms or braces. Lift by designated handles only.
- (7) Tank must be drained before installation or removal.
- (8) In event of contamination by chemicals, wash with soap and water.

B. Liquid Loading Pump

- (1) To prevent burns, avoid touching muffler during operation.
- (2) Do not fill fuel tank while engine is running. Set switch to OFF.
- (3) To allow for fuel expansion, never fill fuel tank to top.
- (4) When unscrewing fuel cap, keep face and eyes turned away from fuel tank. Fuel expands greatly when heated and agitated, and may be discharged from tank when cap is removed.

Change }
No. 1 }

HEADQUARTERS
DEPARTMENT OF THE ARMY
Washington, DC, 30 November 1973

**Operator, Organizational, Direct Support
and General Support Maintenance Manual
SPRAYER, INSECTICIDE, AIRCRAFT-MOUNTED:
WITH PUMP, AGRINAUTIES MODEL NO. 3000, FSN 3740-470-9811**

TM 5374021114, 21 December 1971, is changed as follows:

Page 15. Paragraph 16d(2), is superseded as follows:
(2) *Overall dimensions and weight.* See figure 41 for reduced shipping dimensions.
Weight:

As shipped..... pounds
Flight weight 200 (approx)
and substitute
"Shipping Specifications:
Weight 1020 lbs.
Cube 250.5 cu. in".

Paragraph 1-6(13), line 2. Change model No. "11/4 436TSE" to read "11/2 436RSE". Line 4 change "1-1/4 in. line size" to read "1-1/2 in. line size".

Page 2-2. Caution is added preceding paragraph 2-4a.

CAUTION

Aircraft maximum operating gross weight is limited to 8500 pounds. Maximum air speed is limited to 110 knots indicated air speed.

Page 23. Paragraph 27c, second sentence of Warning, change "120 knots" to read "110 knots".

Subparagraph (4), add the following caution.

CAUTION

If pressure gage (21, fig. 4-10) fails to register, apply brake (16, fig. 4-10). Return to base, remove pump drain plug (20, fig. 4-10) and spin pump until fluid begins to flow. Takeoff and try again.

Page 3-2. Sections VI and VII are added as follows:

Section VI. CALIBRATION INSTRUCTIONS

3-8. GENERAL

Information presented in this section is for guidance in calibrating aircraft for the dispersal of insecticides. Calibration of the aircraft spray equipment is very important when applying insecticides because of the volume applied per acre. These are specific instructions based upon field experience. Calibration is very simple, but is given in detail for inexperienced persons. General safety precautions are: a. This system should be flushed periodically to remove any trash, condensation or other foreign matter. The system should be flushed after each day of operation.

b. Follow label cautions carefully since handling insecticides presents personal hazards. Practice safety first.

c. Be aware of effects insecticides may have on structural materials.

d. Do not be alarmed if you do not see spray since

label rates are practically invisible.

e. Have pilot practice flying a desired height with a measured reference height (a building, pole, etc.) unless he has previous experience with flying in creased heights used in this type application.

f. Do not fly in winds over 8 m.p.h., or when temperature inversions will prevent droplets from going down.

g. Every formulation has its own flow rate affecting rate of application. Flow rate must be known; cutting formulation with solvent or diluent will change flow rate. Mixing two formulations of known flow rate will not necessarily result in arithmetical mean rate.

3-9. SELECTION OF CONFIGURATION

The spray system configuration to be selected for any given spray operation is based on the type of

spray, the application rate, the altitude of the air craft, the speed of the aircraft, and the effective swath width. Based upon these factors the nozzle configurations can be selected. Based on previous field experience Chart Number 1 is offered as a plot of altitude vs. effective swath width.

CHART 1. Altitude vs. Swath Width

Altitude	Effective Swath Width
75'	150'
100'	200'
150'	250'

Chart Number 2 is based on the weights of various solutions with relation to water and conversion factors that are applicable.

CHART 2. Weight and Conversion Factor

WEIGHT OF SOLUTION	SPECIFIC GRAVITY	CONVERSION FACTOR
7.0 lbs/ gallon	.84	1.09
8.0 " "	.96	1.02
8.34 " " -Water	1.00	1.00
9.0 " "	1.08	.96
10.0 " "	1.20	.91
11.0 " "	1.32	.87
12.0 " "	1.44	.83
13.0 " "	1.56	.80
14.0 " "	1.68	.77
15.0 " "	1.80	.75
16.0 " "	1.92	.73

Chart Number 3 indicates the acres per minute covered by an aircraft at various speeds and various effective swath widths and is derived from the following formula:

$$\text{Acres per minute} = \frac{2 \times \text{Effective Swath Width} \times \text{Speed (Miles Per Hour)}}{1000}$$

Chart 3. Acres 1 per Minute

SPEED	ACRES PER MINUTE						
	MPH	KNOTS	50' SWATH	75' SWATH	100' SWATH	200' SWATH	300' SWATH
70	60.9	7.0	10.5	14.0	28.0	42.0	70.0
75	65.3	7.5	11.2	15.0	30.0	45.0	75.0
80	69.6	8.0	12.0	16.0	32.0	48.0	80.0
85	73.9	8.5	11.7	17.0	34.0	51.0	85.0
90	78.3	9.0	13.5	18.0	36.0	54.0	90.0
95	82.6	9.5	14.2	19.0	38.0	57.0	95.0
100	87.0	10.0	15.0	20.0	40.0	60.0	100.0
110	95.7	11.0	16.5	22.0	44.0	66.0	110.0
120	104.4	12.0	18.0	24.0	48.0	72.0	120.0
130	113.1	13.0	19.5	26.0	52.0	78.0	130.0
140	121.7	14.0	21.0	28.0	56.0	84.0	140.0
150	130.4	15.0	22.5	30.0	60.0	90.0	150.0

3-10. FLIGHT TEST CALIBRATION

The selection of nozzle configurations and windmill blade pitch angle settings are preliminary in nature and a flight test must be performed to refine the output performance of the system with the liquid chemicals to be used before initiating an operation. The procedure for adjusting the flow is to increase the windmill blade angle to decrease flow or to decrease the blade angle to increase flow to that required. Retain blade angles between the 1.0 to 2.0 values and remove or add nozzles to fulfill further adjustments that may be required. The pressure in the system should be 40 p. s. i. when calibrating and operating. Procedures for flight testing are noted as follows:

a. With a known liquid quantity in the tank, conduct a spray test for a specific time period and determine the amount of liquid dispersed. The flow

rate is the amount dispersed in gallons divided by the time in minutes.

b. To derive the application rate, divide the flow rate by the swath width and speed factors as follows:

$$\text{Application Rate} = \frac{\text{Flow Rate (gal/min)}}{(\text{gal/acre}) \quad 002 \times \text{swath (ft)} \times \text{speed (mph.)}}$$

c. As noted above, increase windmill blade angle position to decrease application rate or decrease blade angle to increase application rate and repeat tests. Increase or decrease number of nozzles to fulfill requirements if blade angle does not remain within the 1.0 to 2.0 range.

3-11. CALCULATION PROCEDURES

Typical sprays required to effectively accomplish the mission vary between 3 and 32 ounces of application per acre, depending upon the insecticide formulation spray being utilized. Where variations in flight height become necessary, there will of course be a change in swath width. To determine new nozzle configurations to meet the new flow rate as a direct result of changes in swath width and also forward

speed, a calculation procedure is useful. The following is defined to establish the calculation procedure:

a. Establish the rate of application required in gallons per acre. For insecticide application 3 to 32 ounces per acre is required. Each gallon contains 128 ounces; therefore, the application rate varies between 3/128 to 32/128 gallons per acre. For purpose of this calculation we will use 16 ounces per acre which is equal to 16/128 gallons per acre.

b. Select an altitude at which the helicopter will fly. For the purpose of this calculation we will use 100 feet of altitude which should give us an effective swath width of 200' as per information contained in Chart 1.

c. Select a speed at which the helicopter will fly. Based on previous field experience, the normal speeds used for helicopters spraying have been between 70 and 90 knots per hour, which is equivalent to 80.5 to 103.5 miles per hour. For purposes of this calculation we will use 80 knots per hour which is equivalent to 92 miles per hour.

d. Calculate work rate (acres/minute) as follows:

$$\begin{aligned} \text{Acres/minute} &= \frac{2 \times \text{Swath Width} \times \text{Speed (mph)}}{1000} \\ \text{Acres/minute} &= \frac{2 \times 200 \times 92}{1000} = 36.8 \end{aligned}$$

Interpolation in Chart 3 at 92 miles per hour and 200 foot swath indicates the correct answer to be 36.8 acres/minute.

e. Determine the flow rate (g. p. m.) required as follows:

$$\begin{aligned} \text{Gallons/minute} &= \text{gallons/acre} \times \text{Acres/minute} \\ \text{Gallons/Minute} &= 16/128 \times 36.8 = 4.6 \end{aligned}$$

f Select a nozzle tip to fit our nozzle. For purposes of these calculations we will use Spraying System

nozzle tips. With a Spraying System nozzle, at 40 p.s.i., move 3 places from left and place decimal. This will give rate in gallons per minute using water, i.e.:

- 8001 nozzle tip = 0.1 g.p.m.
- 80015 nozzle tip = 0.15 g.p.m.
- 8002 nozzle tip = 0.2 g.p.m.
- 8003 nozzle tip = 0.3 g.p.m.
- 8004 nozzle tip = 0.4 g.p.m.

We will assume that the nozzle tip selected is an 8002, so that the flow rate/nozzle using water would be 0.2 g.p.m. If we were to use an insecticide weighing 10 lbs/gallons, it would have a conversion factor of 0.91 as per information contained in Chart 2, and there fore the actual flow rate/nozzle using the concentrated solution would be 0.2 x 0.91 or 0.182 g.p.m./ nozzle. Chart 4 provides these calculations.

g. Divide the required flow rate (4.6) by the flow rate/nozzle (0.182), to determine the number of nozzles required.

$$\begin{aligned} \text{No. of nozzles required} &= \frac{4.6}{0.182} = 25.3 \text{ use } 26 \\ \text{nozzles. (13 per boom)} & \end{aligned}$$

h. Conduct a flight test to determine the actual flow rate performance that exists.

i. If the flow is too low, increase the pressure in the system, or add additional nozzles, or increase the size of the nozzle tips.

J If the flow is too great, decrease pressure in the system, or delete nozzles, or decrease the size of the nozzle tips.

k. Final adjustments can be made after the first chemical spray operations by the same procedures outlined in steps (9) and (10).

l Record all data on a spray lot sheet (a sample of which is included as (Chart 5) to provide information for new chemical flow charts to be established from these date.

Section VII. PILOTS INSTRUCTIONS

WARNING

Aircraft maximum operating gross weight is limited to 8500 pounds.

WARNING

Maximum air speed is limited to 110 knots indicated air speed.

Chart 4. Flow Per Nozzle in Gallons Per Minute When
The Weight of the Solution Is:

7.0 LBS./GALLON

System Pressure Nozzle/Orifice Tip/Dia.	20 PSI	25 PSI	30 PSI	40 PSI	50 PSI	60 PSI
7.0 LBS./GALLON						
8001=.026	.0763	.0872	.0981	.109	.1199	.1308
80015=.031	.11445	.1308	.14715	.1635	.17985	.1962
8002=.035	.1526	.1744	.1962	.218	.2398	.2616
8003=.043	.2289	.2616	.2943	.327	.3597	.3924
8004=.052	.3052	.3488	.3924	.436	.4795	.5232
8.0 LBS./GALLON						
8001=.026	.0714	.0816	.0918	.102	.1122	.1224
80015=.031	.1071	.1224	.1377	.153	.1683	.1836
8002=.035	.1428	.1632	.1836	.204	.2244	.2448
8003=.043	.2142	.2448	.2754	.306	.3366	.3672
8004=.052	.2856	.3264	.3672	.408	.4488	.4896
9.0 LBS./GALLON						
8001=.026	.0672	.0768	.0864	.096	.1056	.1152
80015=.031	.1008	.1152	.1296	.144	.1584	.1782
8002=.035	.1344	.1536	.1728	.192	.2112	.2304
8003=.043	.2016	.2304	.2592	.288	.3168	.3456
8004=.052	.2688	.3072	.3456	.384	.4224	.4608
10.0 LBS./GALLON						
8001=.026	.0637	.0728	.0819	.091	.1001	.1092
80015=.031	.09555	.1092	.12285	.1365	.15015	.1638
8002=.035	.1274	.1456	.1638	.182	.2002	.2184
8003=.043	.1911	.2186	.2457	.273	.3003	.3276
8004=.052	.2548	.2912	.3276	.364	.4004	.4368
11.0 LBS./GALLON						
8001=.026	.0609	.0696	.0783	.087	.0957	.1044
80015=.031	.09135	.1044	.11745	.1305	.14355	.1566
8002=.035	.1218	.1392	.1566	.174	.1914	.2088
8003=.043	.1827	.2088	.2349	.261	.2871	.3132
8004=.052	.2436	.2784	.3132	.348	.3828	.4176
12.0 LBS./GALLON						
8001=.026	.0581	.0664	.0747	.083	.0913	.0996
80015=.031	.08715	.0996	.11205	.1245	.13695	.1494
8002=.035	.1162	.1328	.1494	.166	.1826	.1992
8003=.043	.1743	.1992	.2241	.249	.2739	.2988
8004=.052	.2324	.2656	.2988	.332	.3652	.3984
13.0 LBS./GALLON						
8001=.026	.056	.064	.072	.080	.088	.096
80015=.031	.084	.096	.108	.120	.132	.144
8002=.035	.112	.128	.144	.160	.176	.192
8003=.043	.168	.192	.216	.240	.264	.288
8004=.052	.224	.256	.288	.320	.352	.384
14.0 LBS./GALLON						
8001=.026	.0539	.0616	.0693	.077	.0847	.0924
80015=.031	.08085	.0924	.10395	.1155	.12705	.1386
8002=.035	.1078	.1232	.1386	.154	.1694	.1848
8003=.043	.1617	.1848	.2079	.231	.2541	.2772
8004=.052	.2156	.2464	.2772	.308	.3388	.3696
15.0 LBS./GALLON						
8001=.026	.0525	.060	.0675	.075	.0825	.090
80015=.031	.07875	.090	.10125	.1125	.12375	.135
8002=.035	.1050	.120	.1350	.150	.1650	.180
8003=.043	.1575	.180	.2025	.225	.2475	.270
8004=.052	.2100	.240	.2700	.300	.3300	.360
16.0 LBS./GALLON						
8001=.026	.0511	.0584	.0657	.073	.0803	.0876
80015=.031	.07665	.0876	.09855	.1095	.11045	.1314
8002=.035	.1022	.1168	.1314	.146	.1606	.1752
8003=.043	.1533	.1752	.1971	.219	.2409	.2628
8004=.052	.2044	.2336	.2628	.292	.3212	.3504

CHART 5. System Log (Sample)

GENERAL	PRE-FLIGHT DATA	
1. Flight Test No. _____	1. Nozzle Configuration _____	
2. Date _____	(a) Nozzle Type _____	
3. Location _____	(b) No. Of Nozzles _____	
4. Purpose _____	(c) Core _____	
5. Aircraft Cmdr. _____	(d) Orifice _____	
6. Spray Controller _____	2. Windmill Blade Setting _____ deg	
7. System Serial No. _____	3. Fluid Quantity _____ gal	
8. Aircraft Serial No. _____	4. Name Of Fluid _____	
IN-FLIGHT DATA		
1. Mission Duration _____ min	5. Concentration _____	
2. Time Spray Is On _____ min.	6. Bypass Position _____	
3. Amount Sprayed _____ gal	7. Desired Swath Spacing _____ ft	
4. Spray Pressure _____ ft	8. Desired Flight Height _____ ft	
5. Actual Flight Height _____ ft	9. Desired Air Speed _____ knots	
6. Actual Air Speed _____ knots	10. Application Rate _____ gal/acre	
7. Actual Swath Spacing _____ ft	SPECIAL COMMENTS	
8. Wind Velocity _____ mph	_____	
9. Wind Direction _____ deg	_____	

NOZZLE PLACEMENT



○ Booming Opening

■ Nozzle Position

Page 46. Paragraph 43a(6) is changed to read as follows:

(6) Control panel should always be placed in UH-1B position (fig. 45) to assure that the helicopter console is cleared. In some model helicopters the map case must be removed to permit clearance of the control panel. Installation required that the folding

brace (1) be attached in the uppermost position on the tank support center brace (2). The control panel must be in its innermost position in the control panel support (3). Use short valve rod (10) and connect. between valve lever (11) and lever on control valve (25, fig. 12). Refer to paragraph 424, step e(3) for instructions on attaching valve rod.

Page 4-15. Add the following to table 4-3.

Table 4-3. Organizational troubleshooting chart

Malfunction	Probable, Cause	Corrective Action
10. Windmill pump fails to build up pressure.	Pump requires priming.	Remove pump drain plug, spin pump until fluid flows and remove boom ends until fluid flows.

By Order of the Secretary of the Army:

CREIGHTON W. ABRAMS
General, United States Army
Chief of Staff

Official:

VERNE L. BOWERS
Major General, United States Army
The Adjutant General

Distribution:

To be distributed in accordance with DA Form 1225A (qty rqr block No. 149) operator maintenance requirements for Insect and Pest Control Equipment.

**OPERATOR, ORGANIZATIONAL, DIRECT SUPPORT AND
 GENERAL SUPPORT MAINTENANCE MANUAL
 SPRAYER, INSECTICIDE, AIRCRAFT MOUNTED: WITH
 PUMP, AGRINAUTICS MODEL NO. 30000**

FSN 3740-470-9811

			Paragraph	Page
CHAPTER	1.	INTRODUCTION		
Section	I.	General.....	1-1-1-3	1-1-1-1
	II.	Description and data	1-4-1-6	1-1-1-5
CHAPTER	2.	OPERATING INSTRUCTIONS		
Section	I.	Service upon receipt of materiel	2-1	2-1
	II.	Controls and instruments	2-2, 2-3	2-2-2-2
	III.	Operation under usual conditions	2-4-2-7	2-2-2-3
	IV.	Operation under unusual conditions	2-8, 2-9	2-5-2-5
CHAPTER	3.	OPERATOR'S MAINTENANCE INSTRUCTIONS		
Section	I.	Basic issue items	3-1, 3-2	3-1-3-1
	II.	Lubrication instructions	3-3	3-1
	III.	Preventive maintenance checks and services	3-4, 3-5	3-1-3-1
	IV.	Troubleshooting	3-6	3-1
	V.	Maintenance of aircraft-mounted insecticide sprayer	3-7	3-1
CHAPTER	4.	ORGANIZATIONAL MAINTENANCE INSTRUCTIONS		
Section	I.	Service upon receipt of materiel	4-1-4-5	4-1-4-11
	II.	Movement to a new worksite	4-6, 4-7	4-1-4-14
	III.	Repair parts, special tools and equipment	4-8-4-10	4-15-4-15
	IV.	Preventive maintenance checks and services	4-11, 4-12	4-15-4-15
	V.	Troubleshooting	4-13	4-15
	VI.	Maintenance of tank, hoses, coupling, strainer, valves, and tubing	4-14-4-19	4-16-4-22
	VII.	Maintenance of boom spray system.....	4-20, 4-21	4-22-4-23
	VIII.	Maintenance of pump and brake assembly	4-22, 4-23	4-23-4-24
	IX.	Maintenance of control system	4-24	4-25
CHAPTER	5.	DIRECT SUPPORT AND GENERAL SUPPORT MAINTENANCE INSTRUCTIONS		
Section	I.	Repair parts, special tools and equipment	5-1--5-3	5-1-5-1
	II.	Troubleshooting	5-4	5-1
	III.	General maintenance	5-5-5-7	5-1-5-2
	IV.	Removal and installation of major components.....	5-8-5-17	5-2-5-6
CHAPTER	6.	REPAIR OF BOOM SPRAY SYSTEM		
Section	I.	Spray boom removal and disassembly	6-1-6-3	6-1 6-1
	II.	Cleaning, inspection, and assembly.....	6-4-6-6	6-4-6-4
CHAPTER	7.	REPAIR OF PUMP AND BRAKE ASSEMBLY		
Section	I.	Synchromatic windmill assembly.....	7-1-7-6	7-1-7-3
	II.	Brake assembly	7-7-7-10	7-3-7-5
	III.	Pump assembly	7-11-7-16	7-5-7-8
CHAPTER	8.	REPAIR OF VALVES, COUPLING, AND TANK		
Section	I.	Flow control and bypass valves	8-1-8-5	8-1-8-4
	II.	Valved quick-disconnect coupling	8-6--8-8	8-5--8-5
	III.	Tank assembly	8-9-8-14	8-5-8-6
CHAPTER	9.	REPAIR OF TANK SUPPORT ASSEMBLY		
Section	I.	Tank support assembly	9-1-9-4	9-1-9-2
	II.	Tank straps, struts, and tiedown lugs	9-5-9-8	9-2-9-2

			Paragraph	Page
CHAPTER	10.	REPAIR OF MANUAL CONTROL PANEL		
Section	I.	General.....	10-1	10-1
	II.	Removal and disassembly.....	10-2, 10-3	10-1-10-1
	III.	Cleaning, inspection, repair, and assembly.....	10-4	10-1
CHAPTER	11.	MAINTENANCE OF LIQUID LOADING SYSTEM		
Section	I.	General	11-1, 11-2	11-1-11-5
	II.	Operator's maintenance instructions	11-3-11-5	11-5-11-5
	III.	Organizational maintenance instructions	11-6-11-8	11-7-11-8
	IV.	Direct support and general support maintenance instructions	11-9	11-13
CHAPTER	12.	ADMINISTRATIVE STORAGE AND INSTRUCTIONS FOR DESTRUCTION OF MATERIEL TO PREVENT ENEMY USE		
Section	I.	Administrative storage	12-1	12-1
	II.	Destruction of materiel to prevent enemy use	12-2	12-1
APPENDIX	A.	REFERENCES		A-1
	B.	MAINTENANCE ALLOCATION CHART		B-1, B-2
	C.	BASIC ISSUE ITEMS LIST AND MAINTENANCE AND OPERATING SUPPLIES		C-1, C-2
INDEX.....				I-1, I-2, I-3, I-4

LIST OF ILLUSTRATIONS

<i>Number</i>	<i>Title</i>	<i>Page</i>
1-1	Insecticide sprayer in UH-1B helicopter	1-2
1-2	Insecticide sprayer - assembled view	1-4
1-3	Insecticide sprayer system - block diagram	1-6
4-1	Aircraft-mounted insecticide sprayer - shipping and storage	4-2
4-2	Insecticide sprayer -- installation details	4-5
4-3	UH-1B installation details	4-7
4-4	UH-1D installation details	4-8
4-5	Alternate control panel positions	4-9
4-6	Turnbuckle safetying diagram	4-10
4-7	Insecticide spray nozzle	4-12
4-8	Blade angle pitch setting.....	4-13
4-9	Tank installation -- exploded view	4-19
4-10	Manual control panel -- exploded view	4-27
6-1	Spray boom assembly - exploded view	6-3
7-1	Sychromatic windmill assembly -- exploded view	7-2
7-2	Brake assembly - exploded view	7-4
7-3	Pump assembly -- exploded view	7-6
8-1	Valve assembly -- exploded view	8-3
8-2	Valve quick-disconnect coupling	8-5
11-1	Liquid loading system	11-1
11-2	Pump assembly	11-3
11-3	Liquid loading system pump engine - wiring schematic	11-4
11-4	Inlet strainer -- exploded view	11-7
11-5	Fabrication of muffler cleaning tool	11-8
11-6	Muffler cleaning	11-11
11-7	Carburetor adjustment controls	11-12
11-8	Fabrication of rotor locking tool	11-14
11-9	Fabrication of offset wrench	11-15
11-10	Fabrication of needle bearing assembly tool	11-16
11-11	Fabrication of bearing and seal tool	11-17
11-12	Fabrication of seal assembling plug	11-18
11-13	Fabrication of seal assembling sleeve	11-18
11-14	Fabrication of piston pin removal tool.....	11-19
11-15	Starter fan housing and ignition parts - exploded view	11-22
11-16	Using rotor locking tool to hold shaft	11-23
11-17	Removal of magneto rotor	11-25
11-18	Starter finger and torsion spring position	11-29
11-19	Carburetor chamber -- exploded view	11-30
11-20	Engine -exploded view	11-32
11-21	Carburetor assembly -- exploded view	11-37
11-22	Pump assembly - exploded view	11-39
11-23	Ball shutoff valve -- exploded view	11-40

LIST OF TABLES

<i>Number</i>	<i>Title</i>	<i>Page</i>
3-1	Operator's Preventive Maintenance Checks and Services	3-2
3-2	Operator's Troubleshooting Chart	3-2
4-1	Nozzle Orifice Data	4-12
4-2	Organizational Preventive Maintenance Checks and Services	4-15
4-3	Organizational Troubleshooting Chart	4-15
5-1	Direct Support and General Support Troubleshooting Chart	5-1
11-1	Operator's Preventive Maintenance Checks and Services	11-5
11-2	Operator's Troubleshooting Chart - Liquid loading System	11-6
11-3	Organizational Preventive Maintenance Checks and Services	11-9
11-4	Organizational Troubleshooting Chart - Liquid Loading System	11-9, 11-10
11-5	Repair and Replacement Standards	11-13
11-6	Fabricated Special Tools	11-17
11-7	Direct Support and General Support Troubleshooting Chart - Liquid Loading System	11-20

CHAPTER 1 INTRODUCTION

Section I. GENERAL

1-1. Scope

a. This manual provides instructions for operation and maintenance of the Agrinautics Model 30000 aircraft mounted insecticide sprayer. Chapters 1 and 2 provide information and operating instructions. Chapters 3 through 5 provide maintenance instructions for operator, organizational, and direct and general support maintenance. Chapters 6 through 10 provide repair information for direct support and general support maintenance. Chapter 11 provides maintenance instructions for the liquid loading system. Chapter 12 provides administrative storage instructions and instructions for destruction of materiel to prevent enemy use.

b. Appendix A contains a list of publications applicable to this equipment. Appendix B contains the maintenance allocation chart. Appendix C contains the basic issue items list (BIIL) authorized

for this equipment, and the list of maintenance and operating supplies required for initial operation.

1-2. Forms and Records

Maintenance forms, records, and reports which are to be used by maintenance personnel at all maintenance levels are listed in and prescribed by TM 38-750.

1-3. Reporting of Errors

Report of errors, omissions, and recommendations for improving this publication by the individual user is encouraged. Reports should be submitted on DA Form 2028, (Recommended Changes to Publications) and forwarded direct to Commanding General, U. S. Army Mobility Equipment Command, ATTN: AMSMEMPP, 4300 Goodfellow Boulevard, St. Louis, Mo. 63120.

Section II. DESCRIPTION AND DATA

1-4. Description

a. *General.* The aircraft mounted insecticide sprayer with pump (fig. 1-1) consists of the insecticide sprayer (fig. 1-2), liquid loading system (fig. 11-1), skid (fig. 4-1), and Government furnished field chest (fig. 4-1). The sprayer is designed for easy installation in a helicopter. Two spray booms extending from the doors on each side of the helicopter are used during operation to spray insecticide from a tank assembly through nozzles in the booms. The tank assembly is mount

ed inside the helicopter on a support structure. Insecticide from the tank assembly is pumped to the spray booms by a windmill type pump controlled by the operator. The tank assembly and other insecticide sprayer components are mounted on a skid to facilitate moving and tiedown. Filling the tank assembly with insecticide is accomplished by use of the liquid loading system interconnected between the tank assembly and external insecticide supply.

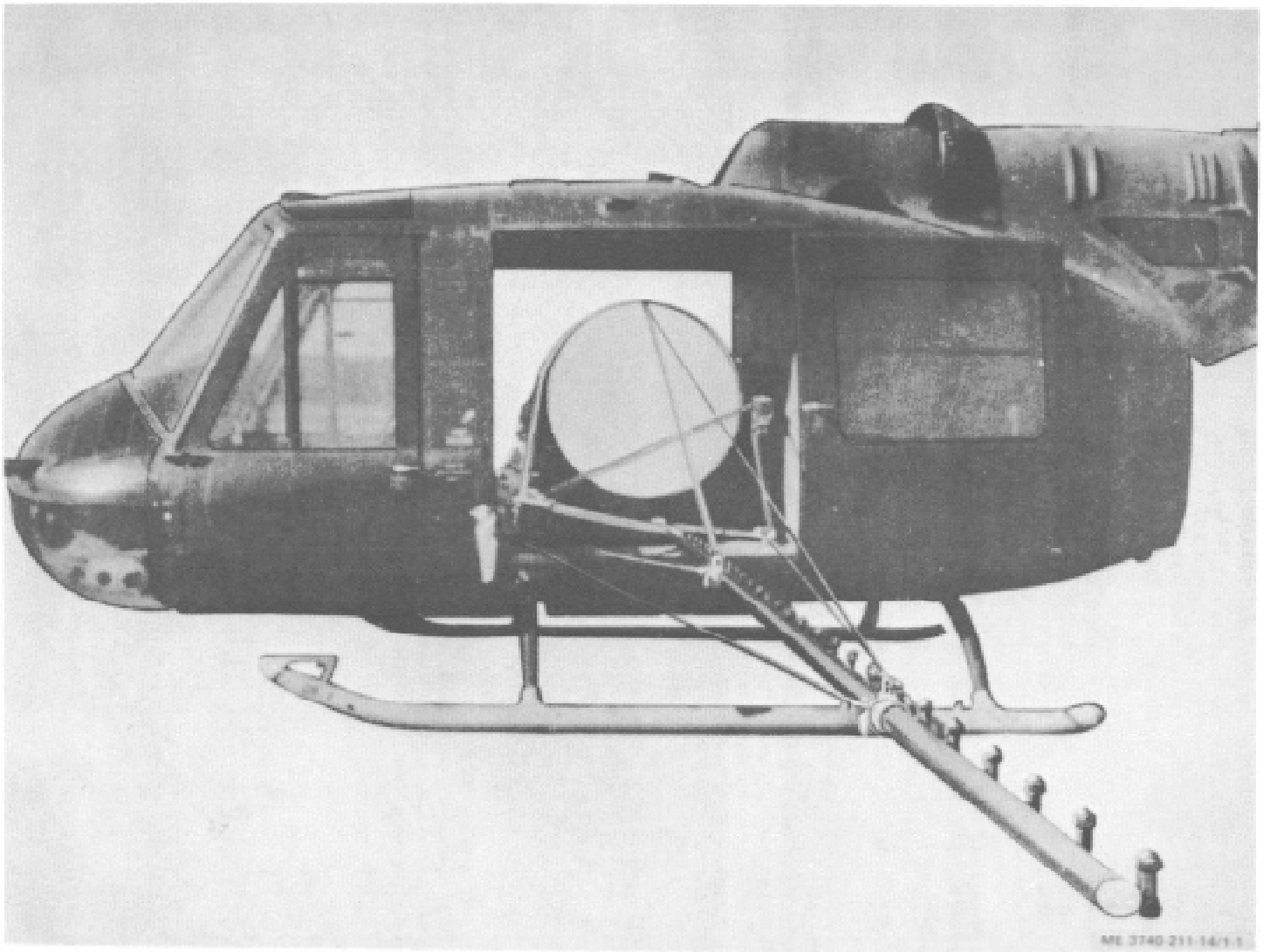

Figure 1-1. Insecticide sprayer in UH-1B helicopter.

b. *Insecticide Sprayer.* The insecticide sprayer (fig. 12) consists of a support structure, tank, windmill driven pump, valves, spray booms and nozzles, and a control system. Normally, the sprayer is not in the helicopter, but is maintained

ready for use. It can be installed in a helicopter by four men in about 1 hour.

Note:

Initial loading, including uncrating, inventory, assembly, and loading, may require about 6 hours.

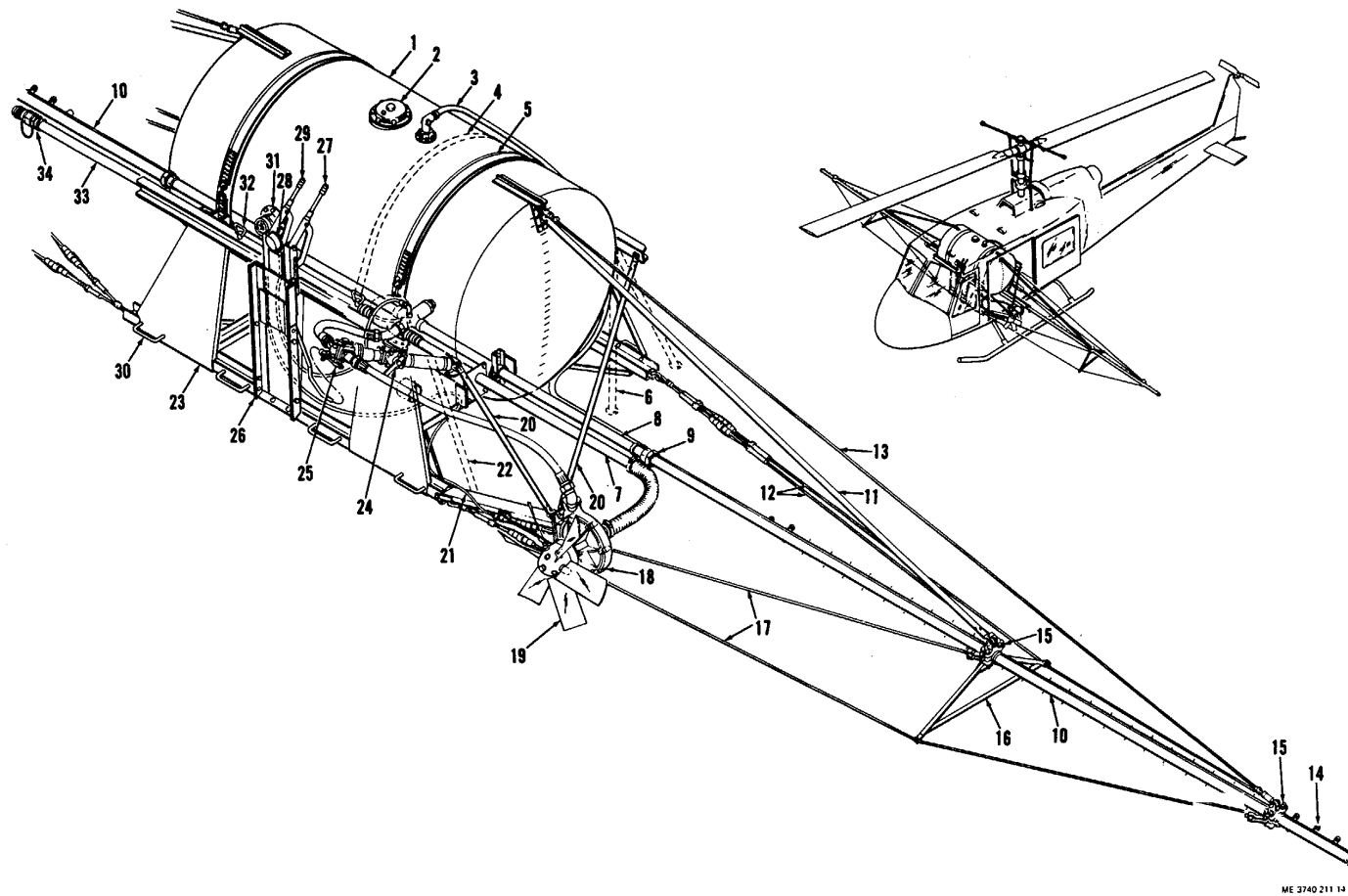

ME 3740 211 14 1 2

- | | | | | | | | |
|----|---|-----|--|-----|---------------------------------|-----|------------------------------------|
| 1. | Tank assembly | 7. | Pump inlet tube | 16. | Boom brace | 25. | Control valve |
| 2. | Filler cap and strainer | 8. | Center boom (with tee strainer assembly) | 17. | Front boom cable | 26. | Manual control panel |
| 3. | Vent and overflow tube | 9. | Boom attaching nut | 18. | Pump and brake assembly | 27. | Valve control lever |
| 4. | Web safety strap-UH-1B installation (WB661-1-52N) | 10. | Boom tube | 19. | Sychromatic windmill | 28. | Pressure gage |
| 5. | Tank strap assembly | 11. | Boom support strut | 20. | Pump strut | 29. | Pump brake lever |
| 6. | Web safety strap-UH-1D installation (WB661-1-25N) | 12. | Rear boom cable | 21. | Pump cable | 30. | Handle |
| | | 13. | Boom support cable | 22. | Web safety strap (WB661-1-52-N) | 31. | Liquid level gage |
| | | 14. | Nozzle assembly | 23. | Tank support | 32. | Strap tiedown end fitting |
| | | 15. | Boom clamp | 24. | Bypass valve | 33. | Ground loading tube |
| | | | | | | 34. | Valved nipple (male)-with dust cap |

Figure 1-2. Insecticide sprayer - assembled view.

c. *Liquid Loading System.* The liquid loading system (fig. 11-1) is used to load insecticide spray fluid into the insecticide sprayer. It is made up of gasoline operated pump with a pump inlet strainer, an outlet ball valve, and three lengths of hose. The hoses and pump inlet and outlet are provided with quick disconnect couplings.

d. *Skid.* The entire insecticide sprayer and liquid loading system is shipped attached to a skid (fig. 41). Included with each sprayer is a field chest holding spare parts and tools. The skid and mounted parts are contained in a specially designed packing crate.

e. *Field Chest.* The field chest (fig. 4-1) is Army supplied and is shipped with the insecticide sprayer. It is used to store spare parts and tools for the sprayer.

1-5. Differences Between Models

The insecticide sprayer may be mounted on either the UH1B or UH1D helicopters with slight changes in the mounting procedure. Refer to paragraph 4-3, step a for details.

1-6. Identification and Tabulated Data

a. *Identification.* The aircraft mounted insecticide sprayer has two identification plates.

(1) *Insecticide sprayer plate.* Located on the right front panel. Specifies nomenclature, manufacturer, model and serial numbers, and tank capacity.

(2) *Liquid loading system pump plate.* Located on the engine fan housing. Specifies nomenclature manufacturer, model and serial numbers, and pump rating.

b. *Instruction.* The aircraft mounted insecticide sprayer has 10 instruction plates.

(1) *Manual control plates.* Eight instruction plates are located on the manual control panel (26, fig. 12). They identify control positions of the control valve and pump brake levers (27 and 29).

(2) *Liquid loading system.* Two instruction plates are located on the liquid loading system pump: switch ON/OFF plate (13, fig. 11-15), and a decal on the pump outlet stating to prime pump before starting engine.

c. *Tabulated Data.*

(1) *Aircraft mounted insecticide sprayer.*

Manufacturer AGRINAUTICS

Model 30000

Serial number range 101 through 128

(2) *Overall dimensions and weight.* See figure 4-1 for reduced shipping dimensions.

Weight:

As shipped 100 pounds

Flight weight (empty) 200 (approx)

Size (without booms) 10 ft (w) x4 ft (d) x38 ft (h):

Length (each boom) 11 ft, 7.78 in.

Length (overall) 31 ft, 5.56 in.

(3) *Pump drive.*

Type Operation Direct coupled, variable pitch, air driven windmill

(4) *Pump.*

Type Centrifugal

Bearing Sealed

(5) *Pump drive brake.*

Type Operation Manually operated

(6) *Spray tank assembly.*

Capacity 195 gallons maximum

Weight Empty: 100 lb (approx)

Filled: Determined by density of fluid used

Size 62 in. (w) by 32 in. (dia)

Material Fiberglass reinforced polyester resin

(7) *Valve control.*

Type Lever, push-pull rod

Type operation Manually operated

(8) *Control valve.*

Type Ball rotor valve, operated manually

(9) *Bypass valve.*

Type Ball rotor valve

Type operation Set manually on ground

(10) *Spray boom.*

Type Hollow aluminum extrusions

Inside diameter 1-5/16 in.

Outside diameter 1 1/2 in.

(11) *Nozzles.*

Type Diaphragm tee-jet

Quantity (both booms) As required (nominally, 60)

(12) *Liquid loading system pump.*

Manufacturer Homelite

Model No XLS 1-3

Type Two-cycle, gasoline powered, manually started, self-priming

(13) *Liquid loading system valve.*

Manufacturer Worcester

Model No 14-436T-SE

Type Manually operated ball

Size 1Y in. line size

(14) *Valved couplers.*

Manufacturer Snap-Tite, Inc.

Model No.

Female AVKC24-24F (TEF)

Male AVKN24-24F (TEF)

Type Double shutoff, quick-disconnect, ball lock, manually operated (15) Insecticide sprayer system. Refer to figure 1-3 block diagram.

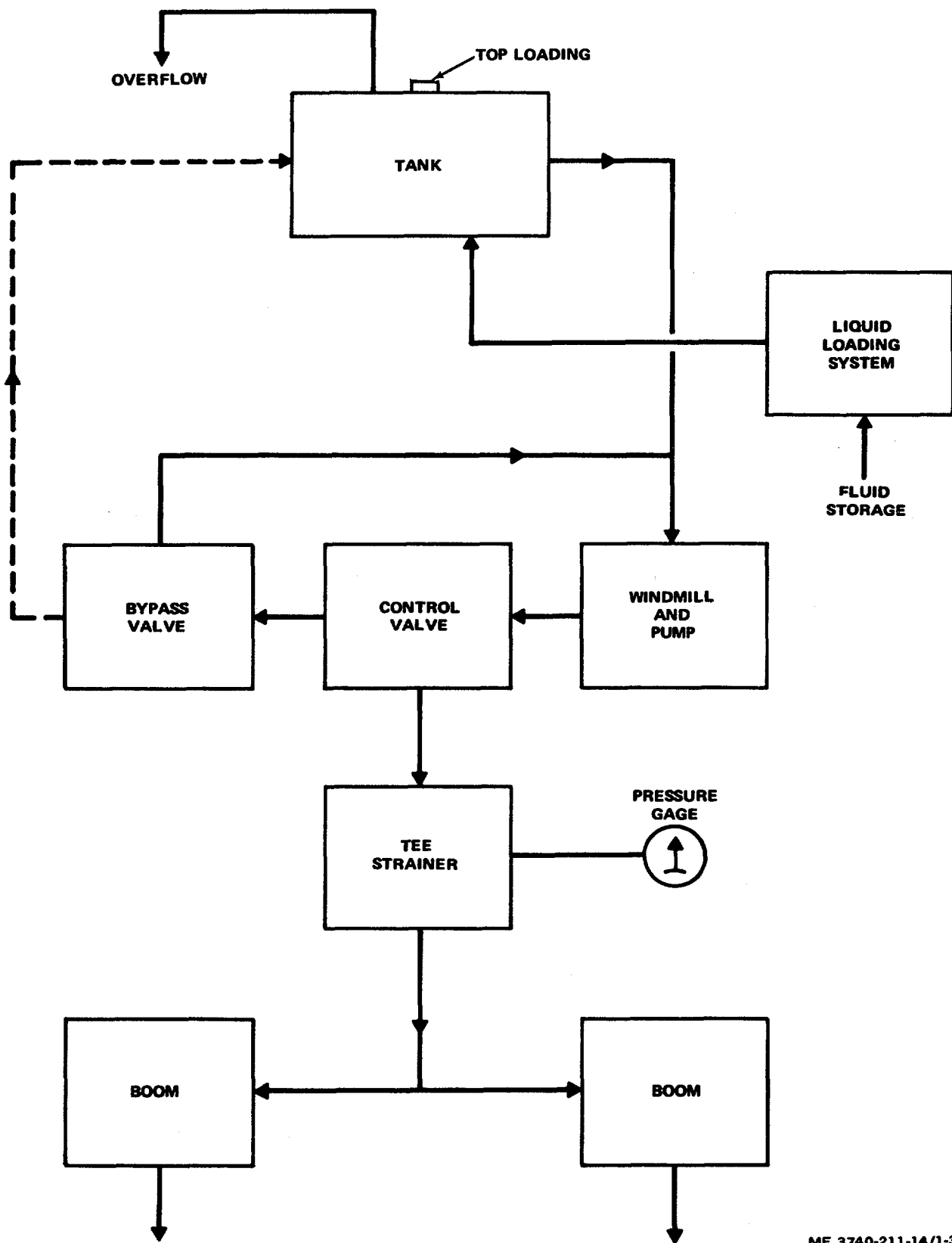

ME 3740-211-14/1-3

Figure 1-3. Insecticide sprayer system - block diagram.
1-6

CHAPTER 2
OPERATING INSTRUCTIONS

Section I. SERVICE UPON RECEIPT OF MATERIEL

2-1. Inspecting and Servicing the Equipment

a. *Insecticide Sprayer.* Prior to each flight, with the insecticide sprayer (fig. 1-2) installed in the helicopter, perform the following preflight checks specified by the Maintenance Allocation Chart (app. B):

- (1) Check all hoses for condition and tightness.
- (2) Check all fluid couplings for tightness.
- (3) Check tank assembly (1) for damage, leaks, and alignment.
- (4) Check vent and overflow tube (3) for condition and tightness.
- (5) Check tank straps (4 or 6, and 22), pump struts (20), and tiedown lugs (28, fig. 4-2) for tightness.
- (6) Check boom tubes (10, fig. 1-2), boom support struts (11), braces (16), struts (20), and cables (12, 13, and 17) for wear, damage, proper tension, and tightness.
- (7) Check all nozzles (14) to assure that tips are clean and are properly aligned.
- (8) Check attach fasteners for pump and brake assembly (18), for tightness.
- (9) Check blades of synchromatic windmill (19) for proper angle setting, as called out in flight and spray plan.
- (10) Check handle of bypass valve (24) for proper position as called out in flight and spray plan.

Note:

Handle is closed in pull position, with flow going back to pump.

(11) Check control valve (25) for operation by using valve control lever (27). If faulty, check for binding in fittings at end of connecting rod.

(12) Check that manual control panel (26) is in proper position.

(13) Check fan brake in locked and unlocked positions by using pump brake lever (29).

Note:

Fan should spin freely by hand when unlocked.

(14) Listen to pump bearings when fan is hand spun to assure freedom from friction.

b. *Liquid Loading System (fig. 11-1).* Prior to using the liquid loading system to load fluid into the insecticide sprayer, perform the following checks:

(1) Check strainer assembly (11), fluid coupler and nipple (4 and 5), hoses (8), and ball valve (2) for tightness and condition.

(2) Check fuel level of pump engine. Add fuel if needed.

WARNING

Fuel and fuel vapors are explosive mixtures. Do not use near open flame. Wash hands after using, before smoking or eating.

CAUTION

Mix fuel in exact amounts. Use only clean, fresh gasoline, and clean mixing cans. Mix oil and fuel well before pouring into fuel tank to insure constant oil content.

(a) Thoroughly mix fuel in a clean fuel can, using the following table as a guide:

Fuel Mixing Table

(1:16 ratio of OE-30 motor oil to regular gasoline)

Oil	% pint	1 pint	1 quart
Gasoline	1 gal	2 gal	4 gal

WARNING

Do not fill gas tank when engine is running, as to do so might cause a fire.

(b) Fill tank to within 1/4 inch of top of filler neck. Use a filler spout or funnel to prevent spillage. Replace gas cap and wipe up any spilled fuel before starting engine.

(3) Inspect engine and pump for general condition. Inspect ignition cable for security.

(4) Check that ball valve (2), is in closed position (handle across tube).

CAUTION

Before starting engine, be sure the pump contains fluid (insecticide or water).

(5) Remove pump filler cap (3, fig. 112) and fill pump body with fluid through opening. Replace cap and gasket.

Note:

Always replace filler cap and gasket after priming pump. The pump cannot self-prime when dry. However, once filled with fluid, the pump will retain fluid for automatic priming and need not be refilled except if overturned or drained.

(6) Start the pump engine and run for about 30 seconds to test for proper operation. Stop engine after this test. Refer to paragraph 2-5, step b for engine starting and stopping.

Section II. CONTROLS AND INSTRUMENTS

2-2. General

This section describes the controls and instruments of the insecticide sprayer and liquid loading system. It also provides information needed to insure proper operation of the equipment.

2-3. Controls and Instruments

a. Insecticide Sprayer. The following controls and instruments are installed on the insecticide sprayer for use in flight operations.

(1) *Manual control panel.* A manual control panel (26, fig. 1-2) is mounted on the front side of the tank assembly, between the pilot and copilot seats. The control panel contains a pump brake lever (29), a valve control lever (27), and a pressure gage (28). The pump brake lever is used to hold or free the windmill for operation, as required. The valve control lever is used to control flow of liquid to the spray booms. Instruction plates showing the control positions are placed next to both valve levers. The pressure gage, within a range of 8 to 100 psi in 2 psi steps, is mounted on top of the manual control panel. The pressure gage reads insecticide fluid pressure at the center of the spray booms.

(2) *Bypass valve.* A bypass valve (24, fig.1-2) is installed partly beneath the tank, between and behind the crew seats. The bypass valve is attached to the tank and opens into the tank. It is used to direct spray fluid back into the tank

or to the pump when the control valve (25) is closed. It is set prior to flight as stated in the flight and spray plan. The valve is hand set to one of two positions, closed or open. The handle position is marked on the valve casting.

b. Liquid Loading System. The following controls used in pump operation are mounted on the pump engine (fig. 11-2):

(1) *Starting rope grip.* The starter grip (9) is attached to a starting cord. Pulling the starter grip turns the engine for starting.

(2) *Choke button.* The choke button (20) is used when starting a cold engine. Pulling the choke button partly out decreases air supply to the engine.

(3) *Ignition ON/OFF switch.* The ignition ON/OFF switch (24) must be ON for starting engine. Placing switch to OFF stops engine.

(4) *Throttle button.* The throttle button (28) is used to control gas flow to the engine. Pushing button in causes engine to speed up. Pulling button out slows engine speed.

(5) *Pump outlet ball valve.* The pump outlet ball valve (2, fig. 11-1) is set by hand to block the pump outlet port. It is used to control insecticide flow when filling tank on insecticide sprayer. Closing this valve also keeps fluid in the pump when test running the engine. The valve is closed when the handle is across the tube.

Section III. OPERATION UNDER USUAL CONDITIONS

2-4. General

a The instructions in this section are to inform and guide personnel operating the aircraft mounted insecticide sprayer and liquid loading system.

b. The operator must know how to perform every operation of which the insecticide sprayer and liquid loading system are capable. This section contains instructions on starting, stopping, and operating the insecticide sprayer and liquid loading system, and on coordinating the basic motions to perform the specific tasks for which the equipment is designed. Since nearly every job presents a different problem, the operator may have to vary given procedures to fit the individual job.

2-5. Starting

a. Insecticide Sprayer. No specific preflight starting procedures are required for the insecticide sprayer. However, the preflight check list of paragraph 21, step *a* must be performed. Perform any preventive maintenance checks and service functions found necessary as listed in

paragraph 34. Refer to paragraph 2-7 for operating procedures.

b. Liquid Loading System. Before starting the liquid loading system pump, perform the check list of paragraph 2-1, step *b*. Perform any preventive maintenance checks and services found necessary as listed in paragraph 11-4. Start the liquid loading system pump as outlined in the following steps (fig. 11-2):

CAUTION

Before starting the engine for the first time after unpacking (refer to para 4-2, step *b*), remove spark plug and turn engine over several times to prevent hydrostatic lock.

(1) If engine is cold, loosen fuel filler cap (8). This will relieve a vacuum which may have formed in a cold fuel tank.

(2) Set ignition switch (24) to ON.

(3) If engine is cold, pull choke button (20) outward. If engine is warm, little or no choking should be needed.

(4) Pull starter grip (9) upward with quick, short pulls. Do not pull the starting rope out to the end or allow it to snap back by itself. Hold the cord so it will rewind properly on the pulley.

CAUTION

If you need to stop engine prematurely, flip ignition switch to OFF position.

(5) When engine fires, push choke button halfway in. Continue to crank until engine starts. The engine should start within one to five cranking attempts.

(6) If the engine does not start after several cranking attempts, pull the choke button out and try again.

(7) As the engine warms up, push choke button slowly inward. Always operate the warm engine with the choke all the way in.

(8) Tighten fuel filler cap after engine has started.

Note:

Although the pump engine starts easily at any throttle setting, including idle, supply the engine with all the fuel it wants for "cold starting." After the pump is running and has primed, you can set the throttle to desired pump ing speed by pulling throttle button (28) outward.

2-6. Stopping

a. Liquid Loading System. The liquid loading system pump can be stopped after filling the insecticide sprayer tank or when desired, by performing the following steps (fig. 112):

(1) Pull pump engine throttle button (28) out to slow engine speed.

(2) Place ignition ON/OFF switch (24) to OFF to stop pump engine.

(3) Close pump outlet ball valve (2, fig. 11-1) to stop insecticide flow. Valve is closed when handle is across tube.

b. Insecticide Sprayer. Operation of the insecticide sprayer is stopped as follows (fig. 12):

(1) Place valve control lever (27) to VALVE CLOSED position to stop spray operation.

(2) Place pump brake lever (29) to BRAKE ON position to stop pump operation.

2-7. Operation of Equipment

a. General. Operation of the insecticide sprayer and liquid loading system consists of loading, in-flight checkout, in-flight operation, and post flight operations. Adjustment of the windmill blade angle and changes in nozzle parts are done at the organizational level and are covered in paragraph 45, step b.

b. Loading Procedure. Prepare the insecticide sprayer and liquid loading system for operation

by performing the steps described in paragraph 25. Load liquid into sprayer tank in the following manner (fig. 11-1):

WARNING

Insecticides are poisonous, and should be handled with care. Avoid splashing fluid and excessive contact and breathing of fumes. Wash hands before smoking or eating, after contact with insecticides.

CAUTION

r

(1) Place the liquid loading system on right side of aircraft (pilot side). Place the spray fluid drums within 10 feet of the pump.

CAUTION

Check contents of drum before loading. Be sure contents are in liquid state, and not clotted into lumps. Do not mix water or water-base fluids with oil-base fluids, as mixing will cause the fluids to jell.

(2) Remove large cap from top of fluid drum and place suction pipe (9, fig. 11-1) into drum.

(3) Check that ball valve (2) is in closed position (handle across tube).

(4) Start pump engine and verify that pump is primed. (Refer to paragraph 25, step *b* for starting procedure, and paragraph 21, step *b* (5) for pump priming procedure.)

Note:

A sign that pump is primed is slowdown or laboring of engine.

(5) Remove dust caps from valved coupler (4) and mating valved nipple (34, fig. 12) on insecticide sprayer.

(6) Engage coupler halves, open ball valve (2, fig. 11-1), and start filling sprayer tank. A sealing valve in each coupler half opens upon engagement to allow fluid to flow.

CAUTION

As tank fills, check for leaks. Shut down filling operation at once if any leaks are observed.

(7) Fill tank to desired level, as noted on liquid level gage (31, fig. 1-2), or markers on ends of tank. Do not fill above 195 gallons.

Note:

Tank end markings may not be the same if helicopter is not parked on level pad. In this case, average readings of both ends of tank.

(8) Stop fluid flow by turning ball valve (2, fig. 11-1) so handle is across tube.

CAUTION

Close input valve before detaching hose from sprayer.

(9) Detach hose from aircraft by releasing ball holding ring (fig. 82) with one hand and pulling hose away with other hand.

(10) Replace dust caps on coupler halves.

Place hose end on top of barrel or other place to protect from dirt. Replace cap on fluid drum.

CAUTION

Do not attempt to load insecticide sprayer before mounting and securing sprayer in helicopter.

(11) A second method of filling the tank is through the top filler cap on tank (2, fig. 1-2). A hand pump or bucket and funnel may be used. In either case, use care not to damage the filler neck or strainer, or contaminate the helicopter.

c. In-flight Checkout. Prior to carrying out actual spraying operations, conduct an in-flight checkout of the sprayer system. Perform checkout as follows (fig. 1-2):

WARNING

In-plate checkout of the spray system must be carried out in an area set aside for this purpose to prevent accidental injury or contamination to personnel, animals, or vegetation.

Never exceed an air speed of 120 knots with the spray system installed in the aircraft.

If spray booms vibrate or misalign during flight, reduce speed slowly, land, and adjust tension of cables (ref para 43, steps a(7)(h) through a(7)(l)).

If a leak develops in flight within the sprayer system, apply pump brake at once and stop spraying.

If fan blade is damaged in flight and causes vibration, apply pump brake at once and stop spraying.

CAUTION

Do not allow pump to run without fluid in actual operation.

(1) Subject to flight plan, pump brake lever (29) may be released (BRAKE OFF position) soon after takeoff. This will permit stirring or heating of fluid.

(2) When planned altitude and speed have been reached and aircraft has arrived at test or operational area, proceed with in-flight checkout.

(3) If pump brake has not yet been released, release at this point. Place valve control lever (27) to VALVE OPEN position and observe nozzles for spray.

(4) Observe pressure gage (28) for proper

reading (as stated in flight plan). Observe nozzles for proper operation and flow, and check for system leaks.

(5) After about 30 seconds, close valve control lever (27).

(6) Check nozzles for drip, and again check system for leaks.

(7) Repeat in-flight spray system checkout of steps 3 through 6, above.

(8) Record any troubles noted for future action.

(9) Place pump brake lever (29) in BRAKE ON position, or permit pump to run as stated in flight plan.

Note:

On successful completion of the in-flight checkout, the spray system is ready for operation.

d. In-flight Operation. Conduct in-flight operation as stated in flight plan. Observe safety precautions listed on inside front cover of this manual. Use the following steps and figure 12 as a guide:

(1) Prior to reaching spray area, place pump brake lever (29) in BRAKE OFF position.

(2) At the desired point, move valve control lever (27) to VALVE OPEN position.

(3) Conduct spray operation as stated in flight plan.

(4) At the end swath (pass), move valve control lever to VALVE CLOSED position to stop spray operation.

(5) On completion of spray operation, place brake control lever in BRAKE ON position to prevent overheating of pump.

e. Post Flight Operation. At end of spray mission, the following post flight operations must be performed:

CAUTION

Be sure you drain any fluid still in tank into a drum that contains the same type fluid being used. Do not mix oil-base fluids with water-base fluids.

(1) Tank holds some spray fluid at end of flight and must be drained. Use one length of hose from liquid loading system to connect to valved nipple (34, fig. 1-2) of insecticide sprayer. Drain fluid from tank back into fluid drum.

(2) Using the liquid loading system so that it may be cleaned out also, fill the spray tank with water, or non-corrosive mineral oil. Use water if spray fluid was water-base; use mineral oil if spray fluid was oil-base.

(3) Fly helicopter to an area set aside for dumping, and permit system to unload. Empty tank by spraying in a manner like that described for normal operation in paragraph 2-7, step *d*.

Note:

If desired for cleaning operation, remove nylon plugs from end of spray booms prior to flushing operations to speed up the cleaning and flushing process.

(4) A second but less thorough method of cleaning and flushing the spray system is to dump cleaning fluid by gravity feed while aircraft is on ground. Place valve control lever (27, fig. 12) in VALVE OPEN position for this operation. You

Section IV. OPERATION UNDER UNUSUAL CONDITIONS

2-8. General

Use of the insecticide sprayer system under unusual weather conditions depends much on the capabilities and limitations of the aircraft with which it is used. Refer to the documents which apply to UH1B and UH1D helicopters for special procedures.

2-9. Procedures

a. *General.* To insure proper operation, keep the equipment clean and operate and maintain it as instructed in this manual. The following additional steps are provided for conditions under which the equipment may be expected to operate:

b. *Operation in freezing weather.* Using the system in freezing weather poses the problem of liquids freezing in the pumps, containers, tank, lines, spray booms, and nozzles. Generally, operations will not be carried out when daytime temperatures are at such extremes. However, overnight freezing may be encountered in areas where the equipment is required to operate. It is best to allow the equipment to thaw out naturally, without applying external heat. Thoroughly draining the equipment and covering overnight will reduce the effects of short term freezing weather. The following steps will help protect the liquid loading pump engine from freezing.

(1) Keep fuel tank of liquid loading pump full at all times to prevent moisture buildup. Keep fuel tank cap securely closed except just before starting, when it is loosened to break a possible vacuum.

(2) Use winter grade gasoline in fuel mixture for easier starting.

(3) Before starting engine, check to see if pump is frozen. Pull starter cord just enough to see if crankshaft will turn freely. If pump impeller is frozen fast, heat the pump slowly, until the ice melts.

(4) Start the engine as described in paragraph 25, step b. You may need to crank the engine a few extra times to start. Use extra care to insure that the engine warms up completely before pumping fluid.

(5) Operation in cold weather. Use of the

may also remove the plug from spray boom ends to speed the flushing and draining.

(5) Clean and decontaminate the helicopter, spray system, and liquid loading system as required.

(6) Leave both the control valve (25) and bypass valve (24) in the middle (unlocked) position when the system is not in use.

sprayer system in cold weather may require warming the spray fluid prior to spraying operations. To preheat the fluid, place handle of bypass valve (24, fig. 12) in TANK OPEN position to direct fluid back into tank. Place valve control lever (27) in CLOSED position to direct fluid to the bypass valve. Place the pump brake lever (29) in BRAKE OFF position to permit fluid to circulate for warming.

c. *Operation in extreme heat.* When using the liquid loading system pump in extreme heat, observe the following:

(1) Check the cooling fins on the engine cylinder often to be sure they are clean and not damaged.

(2) If possible, provide shade to protect the unit from the direct rays of the sun.

d. *Operation in dusty areas.* Using the spraying system in dusty areas will require careful inspection and cleaning procedures. Use the following as a guide (refer also to preventive maintenance checks and services, paragraph 34):

(1) Oily surfaces attract dust quite readily.

Therefore, since the insecticide spray in itself may be an oil-base fluid, the spray nozzles and other parts must be inspected and cleaned often.

(2) Keep outer portions of all equipment clean to prevent dirt buildup.

(3) Inspect and repair all leaks and loose connections promptly when leakage is noted.

(4) Inspect and clean filters and strainers often. The liquid loading engine air filter may require weekly or even daily cleaning.

CAUTION

Never run engine with a clogged air filter or with air filter removed.

(5) Always use dust caps provided with liquid loading system quick disconnect couplings. Never drop hoses in dirt.

(6) Keep spray fluid, gasoline, and oil cans covered to prevent dirt getting into these fluids.

(7) Use only clean gasoline and oil in pump engine to prevent clogging of fuel filter wick.

e. *Operation in salt water areas.*

(1) Salt water and sea air are very corrosive. If the equipment is used in a salt water area,

flush often with fresh water. Then wipe dry and protect the finish by wiping with an oily rag. (2) Paint exposed metallic surfaces if paint has been removed. Coat exposed ferrous metal surfaces with a standard issue rust-proofing material if available, or cover parts with a light film of grease.

f Operation at high altitudes.

(1) Operation of the insecticide sprayer at high altitudes may require insecticide tank to be only partially filled. Consult UH1B or UH1D manuals for takeoff weight restrictions.

(2) Liquid loading system pump engine power output will decrease at a rate of 31/2 percent for each 1000 foot increase in elevation. Pump output will decrease accordingly as engine output decreases.

(3) Maintain maximum performance of pump engine by following all service instructions carefully. Be sure the air cleaner element is not clogged.

(4) Pump engine carburetor may require readjustment for high altitude operation. Refer to paragraph 118, step *f* for instructions.

CHAPTER 3 OPERATOR'S MAINTENANCE INSTRUCTIONS

Section I. BASIC ISSUE ITEMS

3-1. General

a. Tools, equipment, and repair parts issued with or authorized for the aircraft-mounted insecticide sprayer are listed in the basic issue items list, appendix C.

b. Refer to chapter 11 for Operator's maintenance instructions for the liquid loading system.

3-2. Repair Parts and Special Tools List

Refer to the Repair Parts and Special Tools List Manual, TM 5-3740-211-24P for a complete list-ing and illustrations of repair parts and special tools used with the aircraft-mounted insecticide sprayer.

Section II. LUBRICATION INSTRUCTIONS

3-3. Detailed Lubrication Information

a. General. Keep all lubricants in closed containers and store in a clean, dry place away from external heat. Allow no dust, dirt, or other foreign material to mix with the lubricants. Keep all lubrication equipment clean and ready to use.

b. Cleaning. Keep all external parts not requiring lubrication clean of lubricants. Before lubricating the equipment, wipe all lubrication points free of dirt and grease. Clean all lubrication points after lubricating to prevent accumulation of foreign matter.

c. Insecticide Sprayer. Most components of the insecticide sprayer are adequately lubricated at assembly for the life of the system. Therefore, no scheduled lubrication periods have been established.

d. Windmill Pump and Brake Assembly. Lubrication of the windmill driven pump is accomplished by the fluid being pumped.

CAUTION

Never allow the pump to operate dry. If fluid is not being pumped, apply pump brake.

Section III. PREVENTIVE MAINTENANCE CHECKS AND SERVICES

3-4. General

Insure that the aircraft mounted insecticide sprayer system is ready for use at all times. Inspect the equipment following a regular plan so that defects may be found and corrected before they result in serious damage or failure. Perform the needed preventive maintenance checks and services listed in paragraph 35. Item numbers indicate the sequence of minimum inspection requirements. Record any defects found during

operation of the unit for correction to be made as soon as operation has ceased. Stop operation at once if a defect is noted during operation which would damage the equipment if operation is continued.

3-5. Operator's Preventive Maintenance Checks and Services

Table 3-1 lists the operator's preventive maintenance checks and services and functions.

Section IV. TROUBLESHOOTING

3-6. Troubleshooting Chart

Table 3-2 lists the Operator's troubleshooting activities for the insecticide sprayer. The chart

serves only as a guide and does not preclude the possibility of other troubles existing.

Section V. MAINTENANCE OF AIRCRAFT MOUNTED INSECTICIDE SPRAYER

3-7. General

Maintenance duties of the operator/crew of the insecticide sprayer consist primarily of inspecting the equipment to determine its serviceability and keeping the equipment clean. Discrepancies are logged for service by higher level maintenance activities. Exceptions to this procedure are as follows:

a. *Servicing.* Service liquid loading system pump engine by cleaning air filter, intake strainer, and exterior, and by filling the fuel tank with the proper fuel/oil mixture.

b. *Cleaning.* Cleaning the equipment is accomplishing by draining, flushing, and decontaminating the sprayer system, aircraft, and liquid load-ing system components promptly upon completion of spraying operations.

Table 3-1. Operator's Preventive Maintenance Checks and Services.

Item No.	Daily Interval			Item to be inspected	Procedure	Reference
	B	D	A			
01 02	X			Insecticide sprayer Pump assembly	Perform pre-light check Do not allow to run dry	2-1 2-7c 3-3d
03		X	X	Insecticide sprayer	Perform post flight check	2-7e

¹B = before operation; D = during operation; A = after operation.

Table 3-2. Operator's Troubleshooting Chart.

Malfunction	Probable cause	Corrective action
1. Booms noticeably vibrate or misalign in flight	Cable tension out of adjustment.	Land aircraft and adjust tension (4-3a (7)).
2. Leak develops in system during flight.	Faulty fluid system components.	Apply pump brake; stop operations (2-7d).
3. Use of pump causes vibration.	Fan blade damaged, or pump bearings faulty.	Apply pump brake; stop operations (2-7d).
4. No response to start spray command.	a. Loose connection or connector on control valve.	Cancel mission; return to base (2-7d).
b. Inlet or outlet couplings split.	Cancel mission; return to base (2-7d).	Stop pump at once using pump brake (2-7d).
5. No response to stop spray command.	Loose connection or connector on control valve.	
6. Spray intermittent.	a. Brake cable or cable connector loose.	See footnote at end of table.
	b. Faulty windmill drive on pump.	See footnote at end of table.
7. Spray uneven	a. Contamination in spray nozzle.	See footnote at end of table.
	b. Faulty pump.	See footnote at end of table.
	c. Boom tee strainer clogged.	See footnote at end of table.

For intermittent or uneven spray, record condition for service. Depending upon severity of condition, complete or discontinue mission.

CHAPTER 4
ORGANIZATIONAL MAINTENANCE INSTRUCTIONS

Section I. SERVICE UPON RECEIPT OF MATERIAL

4-1. Inspecting and Servicing the Equipment

a. General. Each aircraft mounted insecticide sprayer is shipped and stored in a skid (fig. 41). The sprayer and skid are enclosed within a shipping crate. The insecticide sprayer is shipped fully assembled, except with the spray booms, nozzles, and windmill fan detached, as shown in figure 4-2. The spray nozzles are to be installed

in the spray booms upon field assembly of the equipment. Included on the skid are the liquid loading system and a field chest containing tools and spare parts.

b. Uncrating and Inventory of Equipment (fig. 41). Uncrate the insecticide sprayer, liquid loading system, and field chest. Check for missing parts.

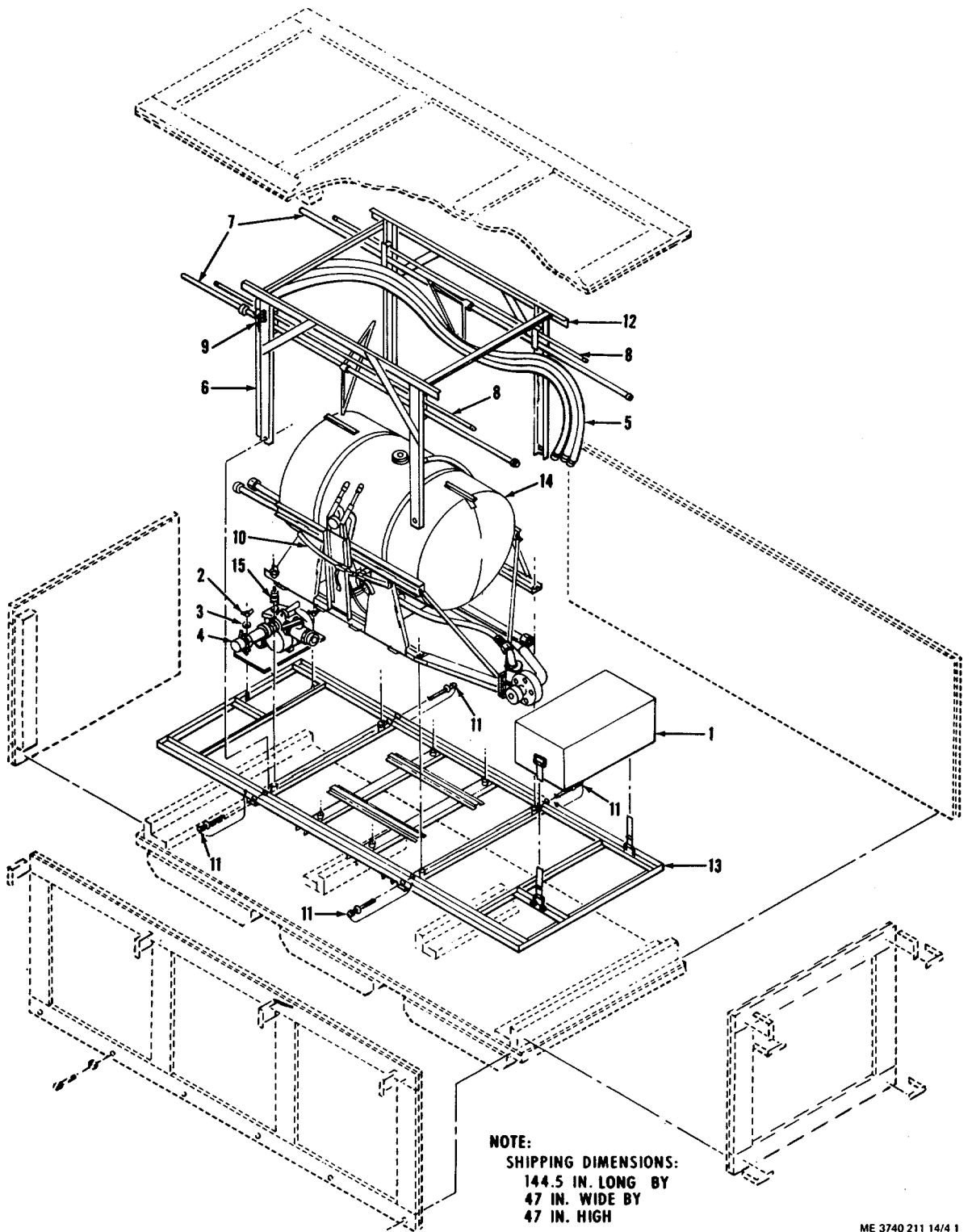

- | | | | |
|-------------------------------|---|---------------------------------|---------------------------|
| 1. Field chest | 5. Liquid loading system hoses (4 reqd) | 8. Boom braces | 12. Skid frame |
| 2. Nut (2 reqd) | 6. Liquid loading system suction pipe | 9. Control valve rods | 13. Skid base |
| 3. Washer (2 reqd) | 7. Spray booms and cables | 10. Web straps | 14. Tank installation |
| 4. Liquid loading system pump | | 11. Quick release pins (4 reqd) | 15. Tiedown lugs (8 reqd) |

Figure 4-1. Aircraft-mounted insecticide sprayer - shipping and storage.

(1) Remove shipping crate in sequence marked on outside of the removable side panel of the crate (ref. Military Specification MILS 52623 (ME)).

(2) Remove field chest (1). Count all parts enclosed in chest and check against basic issue items list (app C). Record any shortages noted. Use tools from chest as needed for removal of remainder of equipment.

(3) Remove wing nuts and washers (2 and 3) and liquid loading system pump (4).

(4) Remove liquid loading system hoses (5) and suction pipe (6).

(5) Remove spray booms and cables (7) and boom braces (8).

(6) Remove control valve rods (9), web straps (10) holding control panel in place, and all small components from skid frame.

(7) Detach quick release pins (11) and remove skid frame (12) from skid base (13).

(8) Remove cotter pins from each of eight tiedown lugs (15), and remove lock nuts and washers.

CAUTION

Four men are needed to lift tank installation. Lift by handles only; do not lift by braces or spray booms.

(9) Remove tank installation from skid.

(10) Reattach all attachment hardware not part of the insecticide sprayer to the skid. Retain shipping crate and skid for later storage and re shipment use.

c. Initial Inspection and Servicing of Equipment. Prior to installing insecticide sprayer into aircraft, perform all inspections allocated to the Operator maintenance level. Perform these inspections to insure that the equipment is in operable condition. Perform the tasks listed in table 4-2.

4-2. Assembly

a. Assemble Insecticide Sprayer (fig. 42). The insecticide sprayer is shipped partly disassembled. Prior to initial installation of the insecticide sprayer into helicopter (refer to P3), install nozzles and synchromatic windmill assembly.

CAUTION

Spray boom tubes may be assembled to tank installation for initial assembly if desired. However, the spray boom tubes must be removed for installation of the insecticide sprayer into the helicopter. Refer to 43 for installation procedures for spray boom assemblies.

(1) Install nozzles (16) to boom tubes of spray boom assemblies (19) as follows:

1. Lockwire, or turnbuckle locking clip, MS21256 (Used for shipping and storage only)
2. Nut, MS 21044C3
3. Washer, MS15795-808
4. Screw, MS51958-66
5. Shackle, wire-rope, MS20115-5
6. Nut, MS21044C3
7. Washer, MS15795-808
8. Screw, MS51958-67
9. Nut, MS21044C3
10. Washer, MS15795-808
11. Screw, MS51958-67
12. Nut, MS21044C4
13. Washer, MS15795-810
14. Clevis bolt, AN24-18A
15. Boom support strut
16. Nozzle
17. Nipple, SAE J530, fig. 1
18. Elbow, SAE J530, fig. 14
19. Spray boom assembly (ref fig. 6-1)
20. Bolt, AN3-22A (3 requd)
21. Nut (1)
22. Washer (1)
23. Bolt (1)
24. Synchromatic windmill assembly (ref fig. 6-1)
25. Cotter pin
26. Lock nut
27. Washer
28. Tiedown lug
29. Tank installation (ref fig. 4-9)
30. Cap, AN929-a4D(1)
31. Plug, AN806-24D(1)
32. Plug, SAE J531

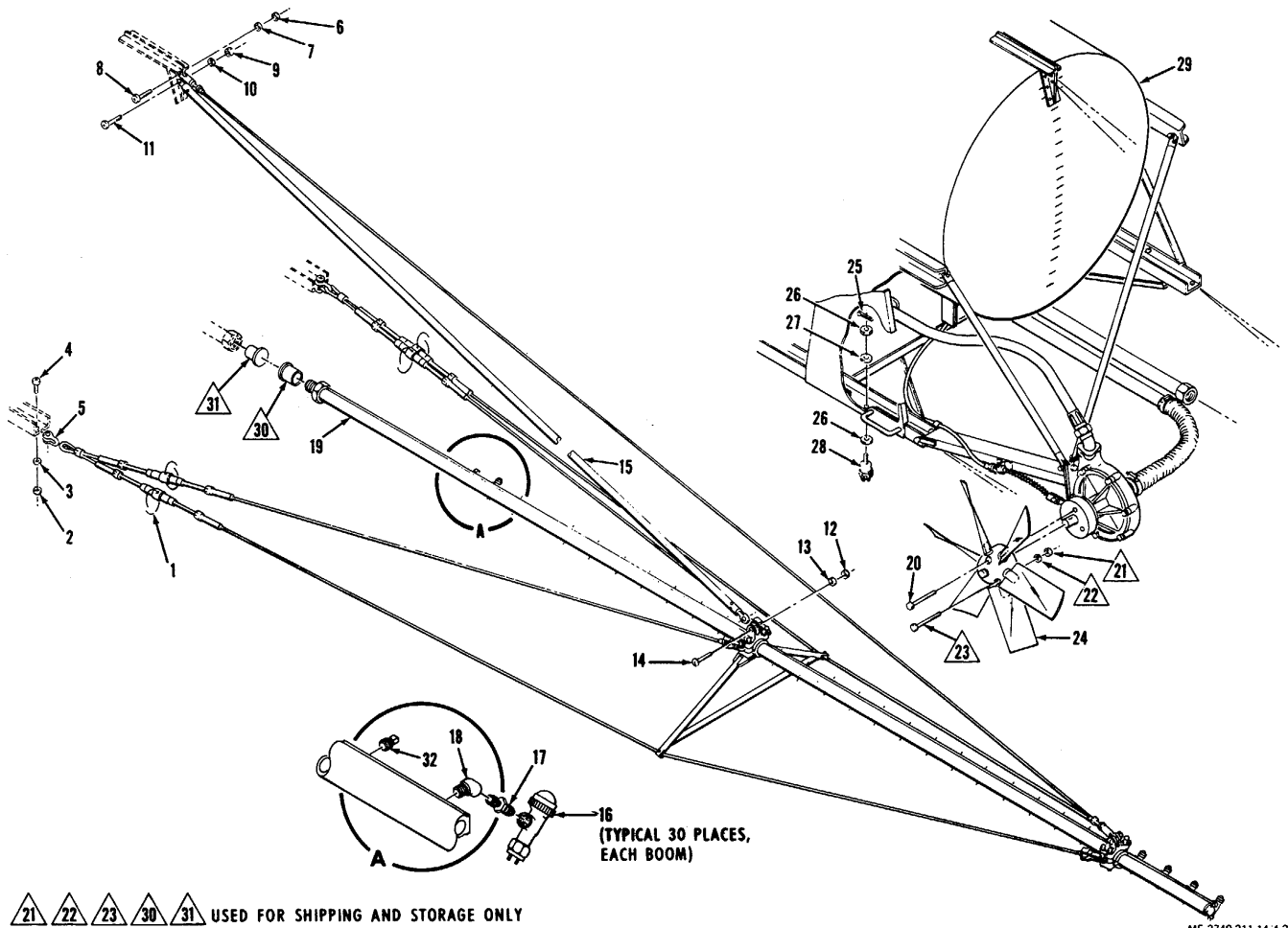

Figure 4-2. Insecticide sprayer - installation details.

- (a) Install elbow (18) in spray boom.
- (b) Install nipple (17) into elbow.
- (c) Attach nozzle (16) to nipple. Tighten

parts snug only.

Note:

Boom tubes have holes for 30 nozzles each.

If nozzles are not required for all holes, use plug (32) in holes not used.

(d) Position all nozzles so that spray orifices face down and forward.

(2) Attach synchromatic windmill assembly (24) to pump and brake assembly of tank installation (29) as follows:

(a) Remove nut (21), washer (22), and bolt (23) used to hold windmill assembly together for shipping or storage.

CAUTION

Do not overtighten bolts when attaching windmill fan to pump and brake assembly.

(b) Attach windmill assembly to pump and brake assembly using three bolts (20). Use a 3/8-inch socket wrench to tighten the attachment bolts. Tighten bolts snug only.

b. Assemble and Test Liquid Loading System.

Assemble the liquid loading system and test run the pump engine using the following steps as a guide:

(1) Assemble the liquid loading system, using figure 11-1 and the following steps as a guide.

(a) Remove dust plugs and caps from the respective valved coupler (4) and valved nipple (5).

(b) Attach hose (8), connected to suction pipe (9), to strainer assembly (11).

(c) Connect remaining hoses (8) together and attach to ball valve (2), using appropriate couplers (4) and nipples (5).

(2) Remove the warning tag attached to the engine, which reads: "Caution: Prior to starting the engine, the spark plug shall be removed and the engine turned over several times to eliminate possibility of hydrostatic lock.

CAUTION

Do not pull starter cord out to end, or let it snap back by itself.

(3) Remove spark plug from engine. Using the starting cord, turn the engine over several times.

CAUTION

Do not allow pump engine to run for more than a few minutes without pumping fluid.

Refer to paragraph 2-1, steps b(4) and b(5) for pump priming procedures.

(4) Install spark plug and start engine using steps described in paragraph 2-5, step b. Allow pump to run for about 30 seconds.

4-3. Installation

a. Install the insecticide sprayer into the UH-1B or UH-1D helicopter, using figure 4-2 and the following steps as a guide:

Note:

Installation is identical for UH-1B or UH-1D helicopter models, except where noted.

(1) Remove tiedown lugs (28) from skid base (13, fig. 4-1).

(2) Place tiedown lugs on studs in cargo deck of the helicopter. See figure 4-3 (UH-1B) or figure 4-4 (UH-1D) to find correct stud locations.

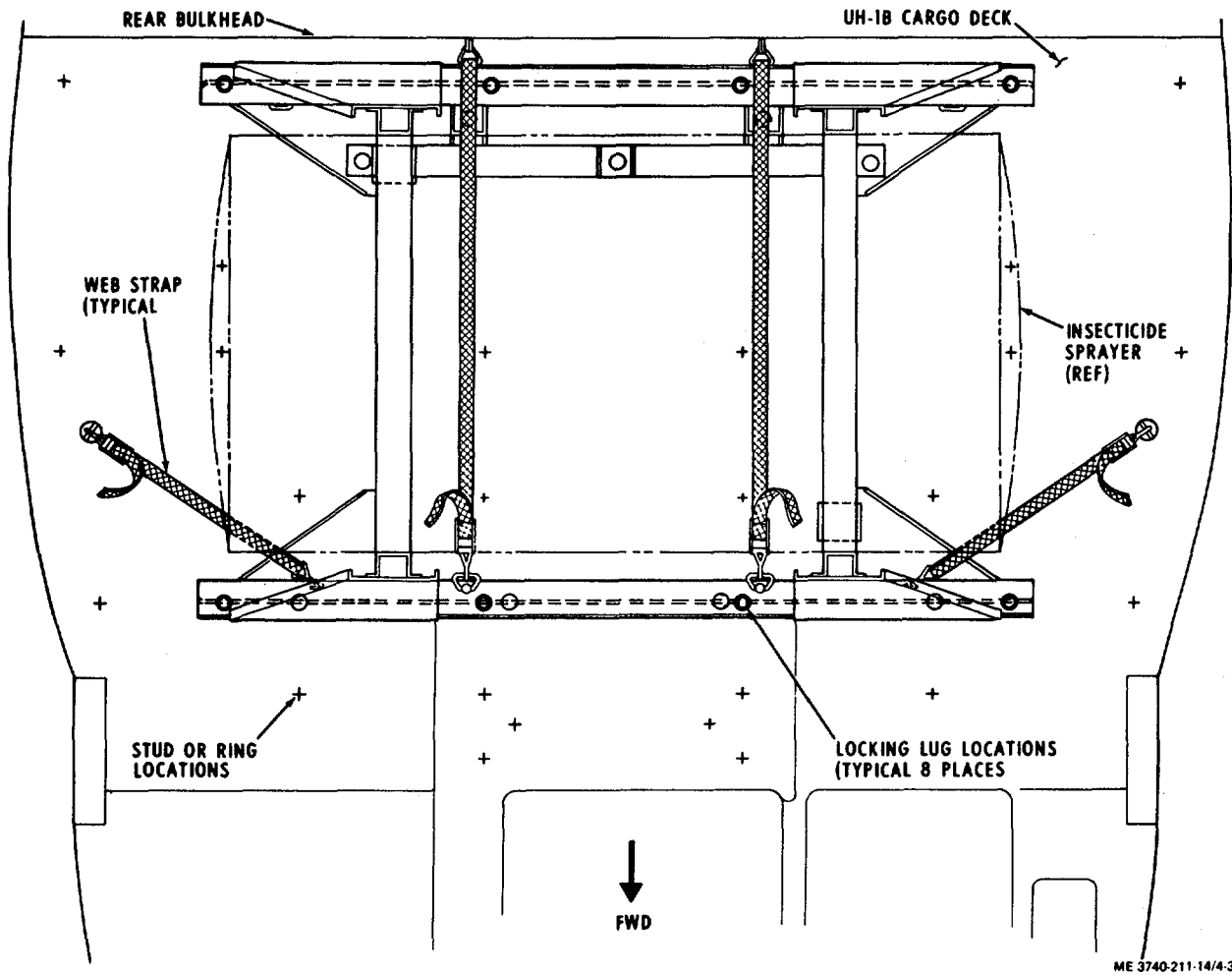
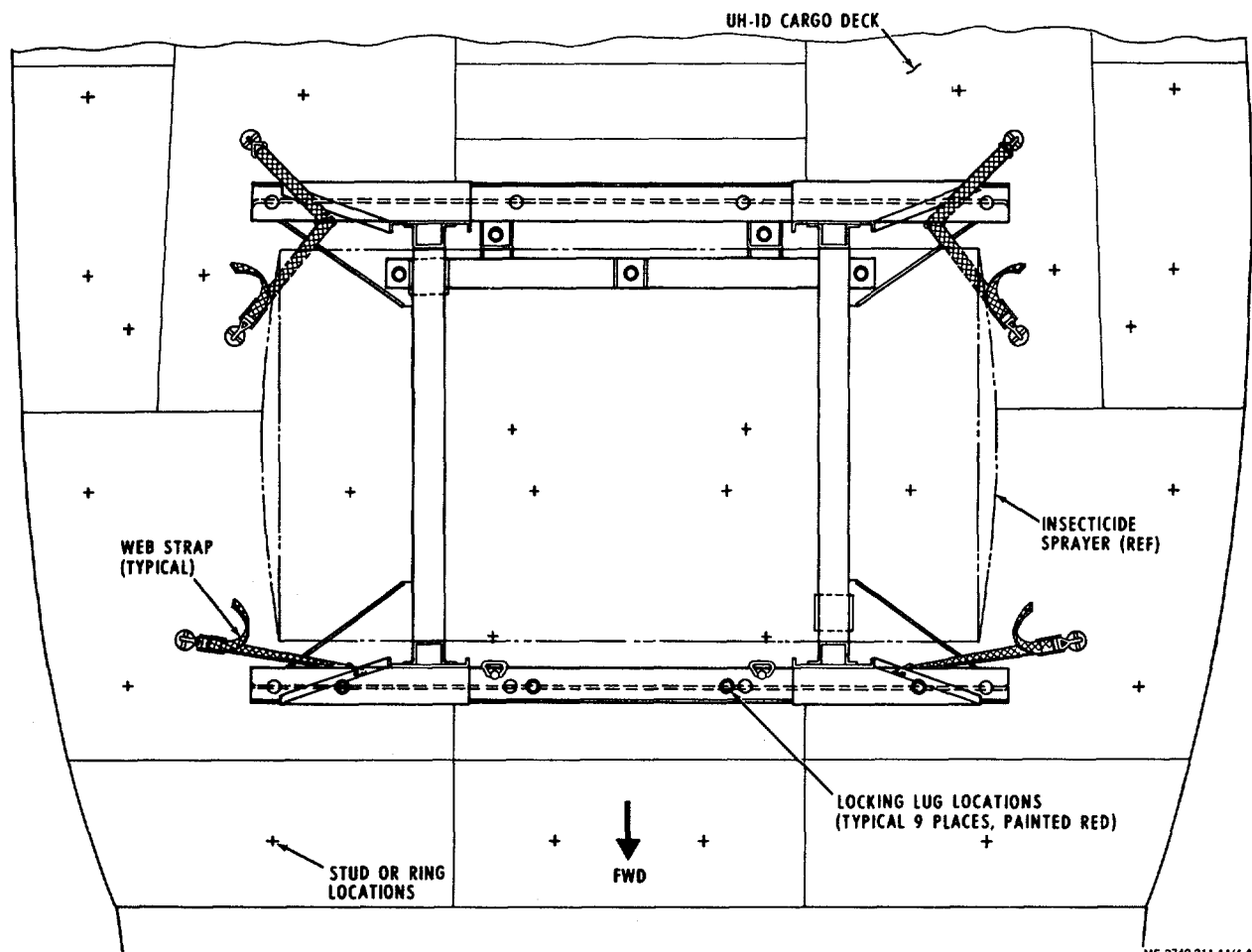

Figure 4-3. UH-1B installation details.



ME 3740-211-14/4-4

Figure 4-4. UH-1D installation details.

CAUTION

Four men are required to load tank installation into aircraft. Do not attempt to lift by booms or braces. Lift by designated handles only. Tank installation must be secured to aircraft prior to attaching spray booms.

(3) Place tank installation (29, fig. 4-2) into aircraft with pump facing forward.

(4) Verify that tiedown lugs (28) are properly placed. Secure lugs to tank support and tank support to aircraft with washers (27), lock nuts (26), and cotter keys (25).

(5) Attach and secure tiedown straps as follows:

(a) UH-1B installation. Attach web safety straps (22, fig. 1-2) between holes in upper channel on front of tank support (23) and cargo rings in stud locations as shown in figure 4-3. Place web safety straps (4, fig. 1-2) over tank. Attach one end to strap tiedown end fittings (32) on front of tank installation.

Attach other end of strap to the lower, center cargo rings attached to helicopter rear bulkhead. Cinch straps down tight.

(b) UH-1D installation. Attach web safety straps (22, fig. 1-2) between holes in upper channel on front of tank support (23) and cargo rings in stud locations as shown in figure 4-4. Attach web safety straps (6, fig. 1-2) to cargo rings of cargo deck as shown in figure 4-4. Run other end of strap through strap tiedown fittings (32, fig. 1-2) on rear of tank installation, and attach to tiedown rings of cargo deck as shown in figure 4-4. Cinch straps down tight.

(6) Extend and adjust manual control panel (fig. 4-5). Control panel position depends upon helicopter model into which insecticide sprayer is installed. The UH-1B installation requires that folding brace (1) be attached in the uppermost position on tank support center brace (2). The control panel must be in its innermost position in control panel support (3). UH-1D installation requires that folding brace be in lower position

and that control panel be in its outer position in control panel support (shown in phantom on figure 4-5). Adjust control panel position as follows:

(a) Remove nuts (4) and bolts (5) securing control panel (6) into control panel support (3). Slide control panel to alternate position (determined by alternate bolt hole positions in panel and panel support). Secure with bolts and nuts.

(b) Remove nuts (7) and bolts (8) securing folding brace (1) to center support of tank support structure. Move folding brace connecting bracket (9) to

alternate position (determined by alternate bolt hole positions in center support). Secure with bolts and nuts.

(c) Place control panel in extended position.

Be sure tang of spring-loaded lock in folding brace arm seats in slotted detent on other brace arm.

(d) Select correct valve rod (10) to go between valve lever (11) and lever on control valve (25, fig. 1-2). Short rod is used on UH-1B; long rod is used on UH-1D. Refer to paragraph P24, step e(3) for instructions on attaching valve rod.

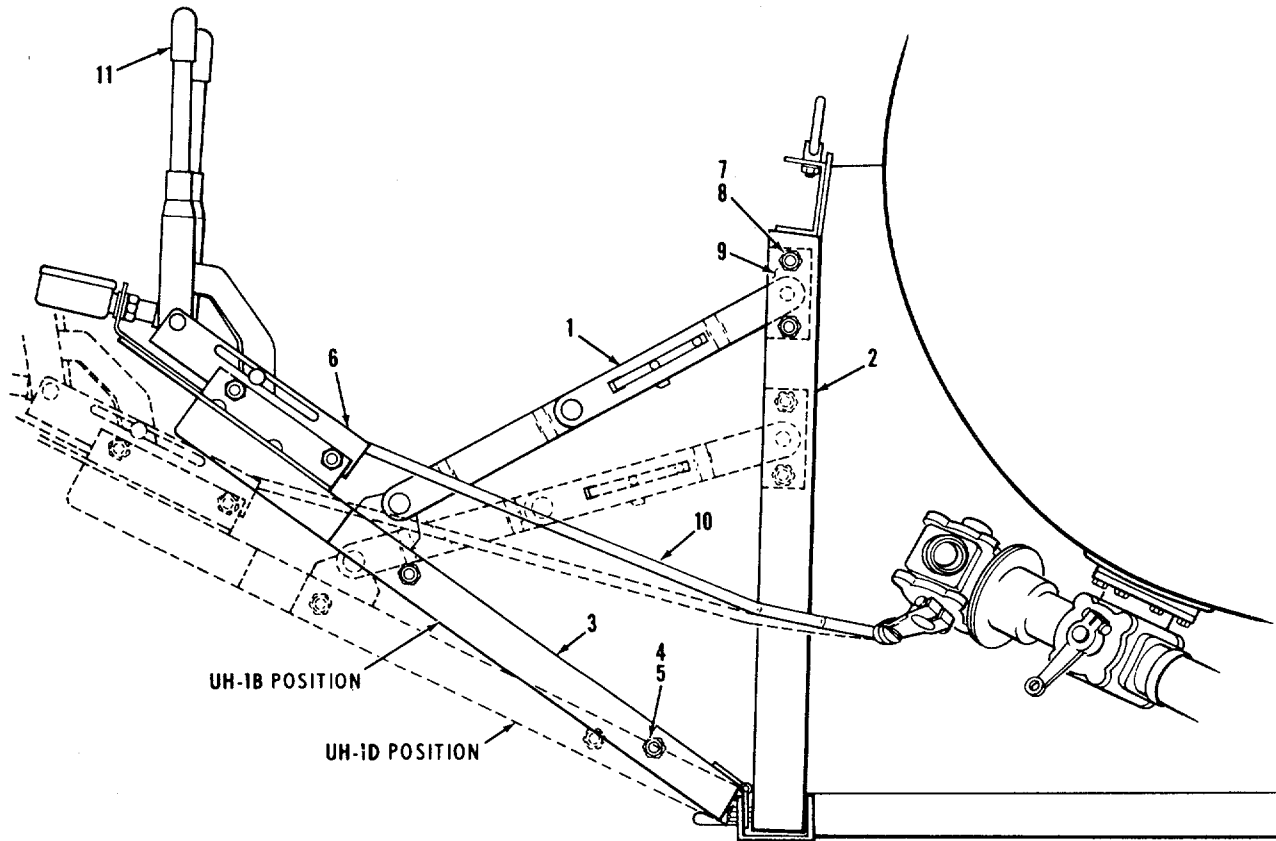

ME 3740-211-14/45

- | | |
|------------------------------|--|
| 1. Folding brace | 8. Nut, folding brace |
| 2. Tank support center brace | 9. Folding brace connecting bracket |
| 3. Control panel support | 10. Valve rod: (for UH-1B, length 25 in.) (for UH-1D, length 38 in.) |
| 4. Nut, control panel | 11. Valve lever |
| 5. Bolt, control panel | |
| 6. Control panel | |
| 7. Wing nut, folding brace | |

Figure 4-5. Alternate control panel positions.

(7) Install spray boom assemblies to tank installation, using figure 4-2 and the following steps as guides:

(a) Remove cap (30) from end threads of boom tube.

(b) Remove plug (31) from end of center section boom on tank installation (29).

(c) Lightly lubricate threads on connector of spray boom tube with suitable thread lubricate.

(d) Attach boom tube to center section boom with nozzles aft. Tighten boom attaching nut handtight only at this time.

(e) Attach boom support strut (15), with rivet heads up, to inboard tube clamp of spray boom assembly (19). Secure with clevis bolt (14), washer (13), and nut (12). Attach other end of strut to lower hole in end bracket located at upper end of tank installation (29). Secure with screw (11), washer (10), and nut (9).

(f) Attach upper boom cable of spray boom assembly (19) to upper hole in tank end bracket of tank installation (29). Secure with screw (8), washer (7), and nut (6).

(g) Attach front and rear boom cables of spray boom assembly (19) to tank installation as follows:

Note:

Front boom cable passes under pump support strut on tank installation (29).

1. Insert wire-rope shackle (5) through loop in end of cable assembly.

2. Secure wire-rope shackle to holes in end of lower channel rail of tank installation (29) with screw (4), washer (3), and nut (2).

(h) Make sure rear boom cables have slack.

Tighten turnbuckle on inboard forward cable until tip of boom is about 3 inches forward of boom centerline.

Then tighten turnbuckle on inboard rear cable to adjust boom back to centerline position.

(i) Repeat the process of step (h) preceding for outboard cables, except reduce boom deflection for this step to 2 inches.

(j) Firmly tighten boom tube to boom center section. Hold boom tube securely with strap wrench, while tightening boom attaching nut.

(k) Check to see if boom tubes are straight.

If not, repeat preceding steps as required.

(l) Upon completion of cable adjustment, if available, use MS 21256 lock clips to secure turnbuckles or 0.041-inch diameter stainless steel lockwire (1, fig. 4-2).

Attach lockwire per figure 4-6, in accordance with MS 33540.

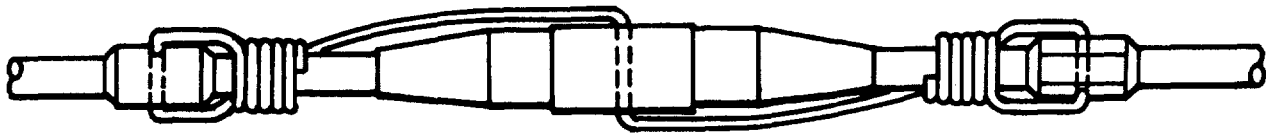

ME 3740-211-14/4-6

Figure 4-6. Turnbuckle safetying diagram.

4-4. Removal from Helicopter

a. Usage of the insecticide sprayer is such that it normally is removed from the helicopter immediately after use. Removal consists of thoroughly flushing and cleaning the system, as well as removal from the helicopter. Use figure 4-2 and the following steps as guides:

(1) Thoroughly drain and clean the tank and all fluid lines as described in the post flight operation (ref para. 2-7, step e). Flush the system thoroughly.

Use noncorrosive mineral oil following use of oil-base spray fluid. Use water following use of water-base spray fluid. Use the liquid loading system for this operation to clean that system at the same time.

(2) Remove spray boom assemblies as follows:

(a) Support spray boom assembly (19) to prevent damage.

(b) Remove lockwire (1) or clips from all turnbuckles. Loosen turnbuckles as needed to provide cable slack.

Note:

Retain all attaching hardware by replacing in attachment points from which removed.

(c) Remove nuts (2), washers (3), and screws (4), retaining wire-rope shackles (5) to tank installation (29). Remove wire-rope shackles from front and rear boom cable assemblies of spray boom assembly (19).

(d) Remove nut (6), washer (7), and screw (8) to detach upper boom cable of spray boom assembly (19) from tank installation (29).

(e) Remove nut (9), washer (10) and screw (11) to detach boom support strut (15) from tank installation (29).

(f) Remove nut (12), washer (13), and clevis bolt (14) to remove boom support strut (15) from spray boom assembly (19).

Note:

Do not remove nozzles from spray booms unless necessary.

(g) Remove nozzles (16), nipples (17), and elbows (18) from spray boom assemblies (19) only if required.

(h) Using a strap wrench to keep spray boom assembly (19) from turning, unscrew boom attaching nut to release spray boom from tank installation.

(i) Cap open ends of spray boom tubes with caps (30). Plug open ends of center section boom on tank installation with plugs (31).

Note:

Do not remove synchromatic windmill assembly (24) from tank installation unless required.

(3) Remove three bolts (20), and remove synchromatic windmill assembly (24) from pump and brake assembly of tank installation. Remove only if required. If removed, secure hubs together using bolt (23), washer (22), and nut (21).

(4) Retract manual control panel of tank installation (29) using the following steps as a guide:

(a) Remove cotter pin, washer, and clevis pin (10, 11, and 12, fig. 4-10), to detach valve rod (15), from lever of control valve assembly (47, fig. 4-9).

Leave attaching hardware in valve control lever.

Lay loose end of valve rod in drip pan beneath tank installation.

(b) Firmly depress locking button on brace arm of control panel, and push control panel to retracted position.

(5) Detach web safety straps (4 or 6, and 22, fig. 1-2) from cargo rings in helicopter cargo compartment (fig. 4-3 or 4-4).

(6) Remove cotter pins, lock nuts and washers (25, 26, and 27, fig. 4-2) from all tiedown lugs (28).

CAUTION

Four men are required to remove tank installation from helicopter. Lift by handles only, never by booms or braces. Do not attempt to remove tank installation with fluid remaining in tank. Refer to paragraph 2-7, step e for tank draining

procedures.

(7) Remove tank installation (29) and tiedown lugs (28) from helicopter.

4-5. Equipment Conversion

a. *Replace in Alternate Aircraft.* The insecticide sprayer may be installed in either the UH-1B or UH-1D helicopters with only slight modification required.

Installation details are described in 4-3. Steps required are:

(1) If not yet removed from helicopter, remove insecticide sprayer (para 4-4).

(2) Attach tiedown lugs to helicopter cargo deck.

Note:

UH-1B requires use of eight tiedown lugs.

UH-1D requires use of nine tiedown lugs.

When not in use, ninth tiedown lug is kept in field chest (1, fig. 4-1).

(3) Install insecticide sprayer into helicopter (refer to para 4-3).

b. *Alteration of Spray Pattern.* Alteration of the spray pattern, as defined by flight and spray plans, may call for alteration of the system in one or more of the following ways:

WARNING

Avoid excessive contact with insecticide spray fluid. Avoid breathing fluid vapors. Following contact with fluid and before eating or smoking, wash hands with soap and water.

CAUTION

Install nozzles and plugs handtight only.

(1) *Quantity of nozzles.* Remove and reinstall spray nozzles and plugs in threaded holes of spray boom tubes as required. Refer to paragraph 4-2, step a(1) for details.

(2) *Orifice size.* The size of orifice in each individual nozzle may be changed as required by the flight and spray plans. Use figure 4-7 and the following steps as guides:

(a) Unscrew cap (1) from body assembly (8).

(b) Remove spray tip (2).

(c) Install new spray tip with orifice size selected from those listed in table 4-1.

(d) Secure nozzle components with cap (1).

Table 4-1. Nozzle Orifice Data.

Dash No. Spray	Vendor part No.	Approx equiv orifice dia	Capacity, gpm, and spray angle at:											
			20 PS		25 PS		30PS		40 PS		50 PS		60 PSI	
			GPM	Spray angle	GPM	Spray angle	GPM	Spray angle	GPM	Spray angle	GPM	Spray angle	GPM	angle
-1	30399-7	0.026	0.07	68	0.08	71	0.09	75	0.10	80	0.11	82	0.12	85
-2	30399-9	0.031	0.11	68	0.12	71	0.13	75	0.15	80	0.17	82	0.18	85
-3	30399-11	0.035	0.14	69	0.16	72	0.17	76	0.20	80	0.23	82	0.25	84
-4	30399-13	0.043	0.21	70	0.24	73	0.26	76	0.30	80	0.34	82	0.37	84
-5	30399-15	0.052	0.28	71	0.32	74	0.35	77	0.40	80	0.45	81	0.49	83

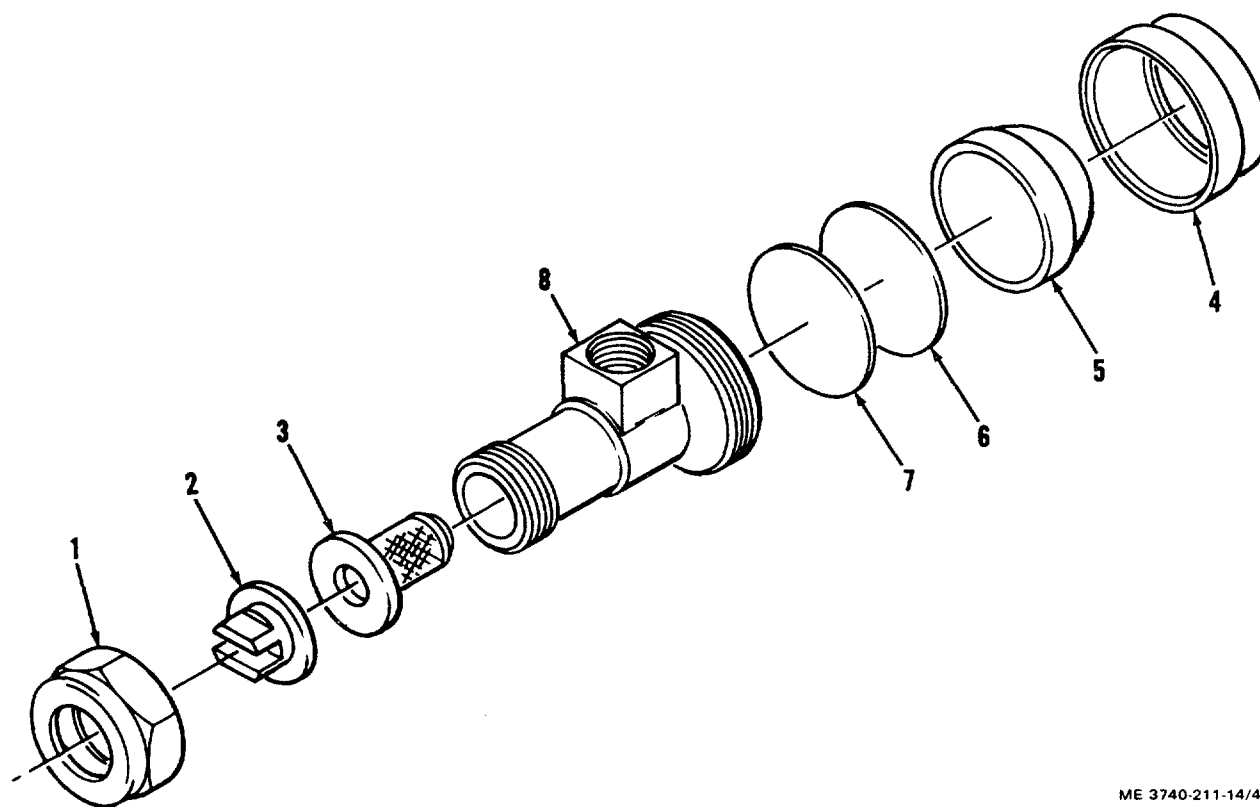

ME 3740-211-14/4-7

- | | |
|----------------------|------------------------|
| 1. Cap | 5. End cap assembly |
| 2. Spray tip | 6. Diaphragm |
| 3. Strainer assembly | 7. Secondary diaphragm |
| 4. Retainer | 8. Body assembly |

Figure 4-7. Insecticide spray nozzle.

(3) Windmill blade angle adjustment. Adjust the blade angle of the synchronic windmill assembly (24, fig. 4-2) as called for in spray plan. Use figure 4-8 and the following steps as guides:

CAUTION
Do not attempt to adjust blades beyond position 1 on hub if you feel resistance when turning adjusting nut. Internal damage to mechanism will result if you do so when parts are binding.

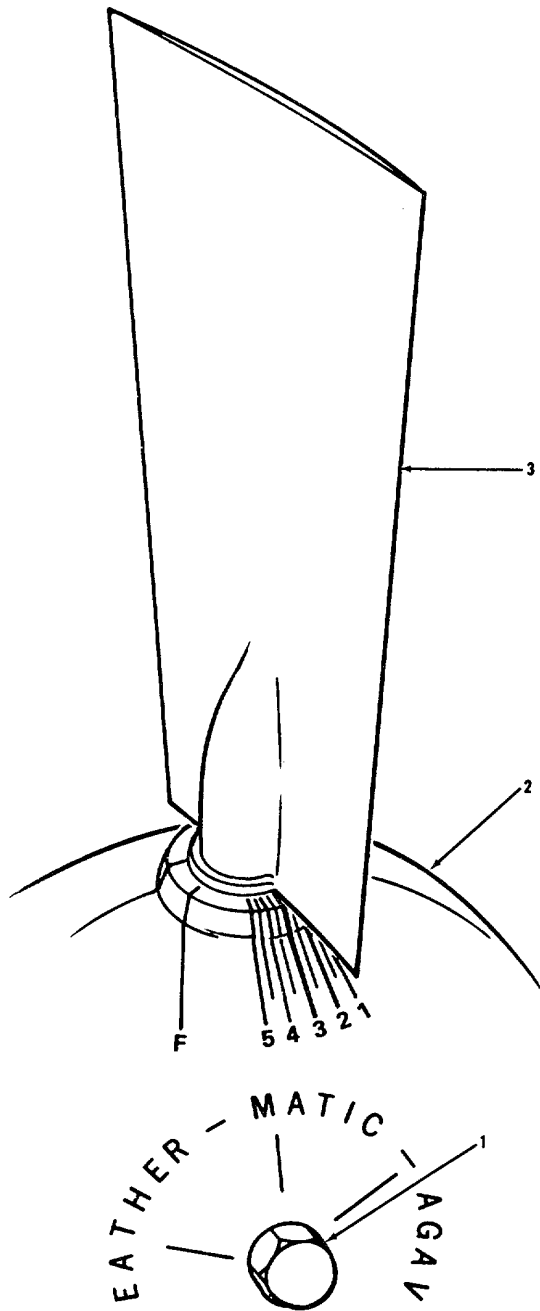

ME 3740-211-14/4-8

1. Adjusting nut
2. Cap hub
3. Blade

Figure 4-8. Blade angle pitch setting.

(a) Turn adjusting nut (1) in center of cap hub (2) clockwise to a setting less than the number you want.

The blade settings is determined when the root edge of blade (3) matches the value marked on the cap hub boss.

(b) Turn adjusting nut in counterclockwise direction and stop at the exact setting. If you overshoot the setting, return blades in clockwise direction to a value less than the desired number then repeat counterclockwise adjustment to the desired setting.

(c) The following list may be used to select blade tip angles:

Actual tip angle	Pitch setting number
350	2 ½ pitch
300	2 pitch
250	1 ½ pitch
200	1 pitch

(d) To feather the blades, turn the adjusting nut until the blade root is in line with the letter F on the hub.

Section II. MOVEMENT TO A NEW WORKSITE

4-6. Dismantling for Movement

a. *Insecticide Sprayer.* Dismantle the insecticide sprayer and prepare for packaging. Use figure 4-2 and the following steps as guides:

(1) If insecticide sprayer is installed in helicopter, remove from helicopter (para 4-4).

Note:

Disassemble components only as necessary for packing in shipping container and to protect parts from damage.

(2) Remove synchromatic windmill assembly (24) from tank installation (29) as described in paragraph 4-4, step a(3).

b. *Liquid Loading System.* Prepare the liquid loading system for reshipment using figure 11-1 and the following steps as guides:

(1) Thoroughly flush the liquid loading system.. Use noncorrosive mineral oil if spray fluid used was oil-base, or water if spray fluid was water-base.

(2) Remove all hose connections at the valved couplers and nipples (4 and 5), and cap all openings with the dust plugs and caps attached to each coupler half.

(3) Prepare the pump (1) engine for shipment using the following steps as a guide:

(a) Start the engine then choke it until it stops, to coat all internal parts of the engine with oil-containing fuel.

Note:

Refer to paragraph 2-5, step b for starting instructions.

(b) Drain the fuel tank and pump cavity by removing the caps and inverting the engine.

Replace caps after draining.

(c) Remove the spark plug from the engine. Preserve the combustion chamber with Type P-10, grade 2 preservative oil per Military Specification MIL-L-21260. While rotating the engine crankshaft, spray 1/4 ounce of preservative oil into the combustion chamber through the spark plug hole. With the crankshaft stopped, spray 1/4 ounce of preservative oil into the spark plug hole. Coat the spark plug threads with a light coating of the preservative oil, and reinstall the spark plug. Attach a warning tag to the engine reading as follows: "Caution Prior to starting the engine, the spark plug shall be removed and the engine turned over several times to eliminate possibility

of hydrostatic lock. "

(d) Protect the finish by wiping the entire unit clean. If the unit has been exposed to salt water or sea air atmosphere, wipe the unit with an oily rag.

c. *Packaging.* Load the insecticide sprayer and accessories on the skid, and package in the shipping crate, using figure 4-1 and the following steps as guides:

(1) Load the tank installation on the skid base and secure in position using the hardware supplied.

Attach skid frame and attach the spray booms, cables, liquid loading pump, hoses, field chest, and other accessories in the specified locations and in the manner provided.

(2) Secure the cables to the booms with tape per Federal Specification PPP-T-97, type II or III to prevent movement.

(3) Place the hinged manual control panel in its most inward position toward the tank (ref para 4-4, step a(4)). Secure the control panel to the adjacent skid frame members with web straps (10).

(4) Secure all other small components which might move within the designated mounting location with reinforced tape per Federal Specification PPP-T-97, type II or III, to prevent movement.

(5) Preserve and package repair parts and tools included with the sprayer system using the methods of Military Specification MILP-116. Package each part or group of similar parts in a paperboard or fiberboard box. Place the packaged repair parts and tools into the field chest (1, fig. 4-1). Cushion or block parts where required to prevent movement within the chest.

(6) Install the insecticide sprayer and all associated components and accessories, mounted on the skid, into the shipping crate. Secure shipping crate in accordance with figures 1 and 2 of Military Specification MIL S-52623 (ME).

4-7. Reinstallation After Movement

The procedure for reinstalling the insecticide sprayer after movement to a new worksite is identical to that for installing new equipment (paras 4-1, 4-2, and 4-3).

Section III. REPAIR PARTS, SPECIAL TOOLS AND EQUIPMENT

4-8. Tools and Equipment

Tools, equipment, and spare parts issued with or authorized for the aircraft mounted insecticide sprayer are listed in the basic issue items list, appendix C.

sprayer.

4-10. Maintenance Repair Parts

Repair parts and equipment covering Organizational maintenance for the insecticide sprayer are listed and illustrated in TM 5-3740-211-24P.

4-9. Special Tools and Equipment

No special tools or equipment are required for Organizational maintenance of the insecticide

Section IV. PREVENTIVE MAINTENANCE CHECKS AND SERVICES

minimum inspection requirements.

4-11. General

Insure that the aircraft-mounted insecticide sprayer is ready for operation at all times. To do so you must perform a systematic inspection so that defects may be discovered and corrected before they result in serious damage or failure. Perform the necessary preventive maintenance checks and services described in 4-12.

The item numbers indicate the sequence of

4-12. Organizational Maintenance Preventive Maintenance Checks and Services

Table 4-2 lists Organizational maintenance level preventive maintenance checks and service functions.

Table 4-2. Organizational Preventive Maintenance Checks and Services

Item No.	Interval					B - Before operation D - During operation	A - After operation W - Weekly	M - Monthly
	Daily			W	M			
	B	D	A			Item to be inspected	Procedure	
01			X		X	Tee boom strainer Hoses, couplings, tank strainer, nozzles. Pump brake cables and controls. Liquid loading system strainer. Windmill blades.	Remove strainer; clean or replace, if required. Clean parts; replace as necessary. Lubricate. Clean; replace if required. Check blade angle and condition; service and replace as necessary.	
02			X		X			
03					X			
04				X				
05	X				X			

Section V. TROUBLESHOOTING

4-13. Troubleshooting Chart

Table 4-3 is a tabulation of troubleshooting steps assigned to Organizational maintenance level for the

insecticide sprayer. The chart serves only as a guide, and does not mean that other troubles may not exist

Table 4-3. Organizational Troubleshooting Chart.

Malfunction	Probable cause	Corrective action
1. Booms tiedown devices. in flight.	noticeably vibrate or misalign	a. Tank installation loose. a. Secure all tank
2. Leak develops in sprayer system.	b. Cable tension out of adjustment.	b. Adjust cable tension as required.
3. Use of pump causes.	Faulty fluid system components.	Repair or replace faulty components.
4. No response to start spray command.	Fan blade damaged.	Replace fan blade.
5. No response to stop spray command.	a. Loose connection on control valve.	a. Adjust and secure connectors.
6. Spray intermittent.	b. Inlet or outlet couplings split.	b. Replace any faulty couplings.
7. Spray uneven.	Loose connection on control valve.	Adjust and secure connectors.
8. Unable to adjust windmill blade pitch angle.	Brake cable or cable connector loose.	Adjust and secure cable.
9. Incorrect pressure gage indication.	a. Contamination in spray nozzles.	a. Disassemble and clean nozzles.
	b. Boom tee screen clogged.	b. Clean or replace screen.
	Internal mechanism damaged.	Replace hub assembly.
	a. Gage damaged or out of calibration.	a. Replace gage.
	b. Pressure line loose or broken.	b. Repair or replace pressure line.

**Section VI. MAINTENANCE OF TANK, HOSES,
COUPLING, STRAINER, VALVES, AND TUBING**

4-14. Tank Assembly

a. *General.* The tank assembly (125, fig. 4-9) is a 200-gallon tank. It is molded from fiberglass reinforced polyester, and has two internal baffles. It is attached to the tank support assembly (133) by two strap assemblies (123) and serves as the reservoir for the spray liquid. Tank spray liquid quantity is displayed by a liquid level gage (110) and by markings on the ends of the tank. The tank is translucent, allowing the fluid level within to be seen. The tank is normally filled from the bottom by the liquid loading system. However, it may be gravity filled through an opening in the top. Brackets for fastening boom support struts and cables are bonded to the top ends of the tank. Attachment

fittings for the following components are bonded within the tank at the respective openings:

- (1) Top strainer and cap assemblies (116 through 119).
- (2) Overflow tube and connector (61 through 64, 111 and 112).
- (3) Liquid level gage (110).
- (4) Bypass valve and gasket (52 and 51).
- (5) Sump and gasket (34 and 33).

b. *Maintenance Adjustment.* Maintenance and adjustment of the tank assembly consists primarily of inspecting the tank for signs of leaks, security of components, and for security of tiedown straps and lugs.

- | | | |
|---|---|--|
| 1. Cotter pin, MS24665-161 | 45. Bolt, AN3-6A | 90. Eye bolt, AN43B-C4A |
| 2. Washer, MS15795-810 | 46. Gasket | 91. Long pump strut |
| 3. Clevis pin, MS9464-14 | 47. Control valve assembly | 92. Nut, MS21044C3 |
| 4. Cotter pin, MS24665-151 | 48. Lockwire | 93. Washer, MS15795-808 |
| 5. Washer, MS15795-808 | 49. Bolt, AN3-H4A | 94. Bolt, AN3C-6A |
| 6. Pin, MS20392-2013 | 50. Washer, AN960-10 | 95. Short pump strut |
| 7. Fork | 51. Gasket | 96. Nut, MS21046C4 |
| 8. Pump link | 52. Bypass valve assembly | 97. Washer, AN970-4 |
| 9. Nut, AN316-6 | 53. Nut | 98. Bushing, NAS-75-4-010 |
| 10. Washer, MS27183-14 | 54. Screw, MS35308-307 | 99. Eye bolt, AN43B-C10A |
| 11. Cable assembly | 55. Nut, MS21044C4 | 100. Nut, MS21044C3 |
| 12. Clamp, MS35842-13 | 56. Washer, MS15795-810 | 101. Washer, MS15795-308 |
| 13. Hose, 13216E5307-5 | 57. Screw, MS35308-307 | 102. Bolt, AN3C-10A |
| 14. Hose, MS28741-20-0520 | 58. Manual control panel
(fig. 4-10) | 103. Nut, MS21044C3 |
| 15. Elbow, MS20823-20D | 59. Nut, MS21044C3 | 104. Washer, MS15795-808 |
| 16. Nut, MS21044C6 | 60. Bolt, MS51957-65 | 105. Screw, MS51958-75 |
| 17. Washer, MS15795-814 | 61. Clamp, MS21104-D24 | 106. Bracket |
| 18. Screw, MS35308-362 | 62. Clamp, MS21104-D30 | 107. Pump support assembly |
| 19. Pump and brake assembly (fig.
7-2 and 7-3) | 63. Clamp, MS35842-13 | 108. Screw, MS21295-36 |
| 20. Clamp, MS35842-13 | 64. Plastic Tube (overflow) | 109. Handle |
| 21. Hose, 13216E5307-2 | 65. Nut, MS2104464 | 110. Liquid level gage |
| 22. Clamp, MS35842-13 | 66. Washer, MS15795-810 | 111. Adaptor, MS24522-34 |
| 23. Hose, 13216E5307-3 | 67. Screw, MS35308-309 | 112. Elbow, MS51952-8 |
| 24. Nut, 21044C4 | 68. Nut, MS2104464 | 113. Screw, MS51958-66 |
| 25. Washer, MS15795-810 | 69. Washer, MS15795-810 | 114. Washer, MS15795-808 |
| 26. Screw, MS35308-319 | 70. Screw, MS35308-309 | 115. Cap |
| 27. Spacer | 71. Spacer | 116. Filler flange |
| 28. Pump inlet tube | 72. Upper clamp | 117. Gasket |
| 29. Clamp, MS35842-13 | 73. Lower clamp | 118. Filler |
| 30. Hose, 13216E5307-3 | 74. Drip pan | 119. Strainer assembly |
| 31. Screw, M551958-66 | 75. Elbow, MS20823-21D | 120. Nut, MS21044C4 |
| 32. Washer, MS15795-808 | 76. Elbow, SAEJ514, fig. 6A | 121. Washer, MS15795-810 |
| 33. Gasket | 77. Plug | 122. Screw, MS35308-320 |
| 34. Sump | 78. Cap | 123. Tank strap assembly |
| 35. Dust cap | 79. Gasket | 124. Cushion |
| 36. Valved nipple | 80. Screen assembly | 125. Tank assembly |
| 37. Nut, 2104404 | 81. Center boom | 126. Nut, MS21044C4 |
| 38. Washer, MS15795-810 | 82. Nut, MS21044C4 | 127. Washer, MS15795-808 |
| 39. Screw, MS35308-319 | 83. Washer, MS15795-808 | 128. Strap end tiedown fit-
tings, NAS1211B15 |
| 40. Spacer | 84. Bolt, AN3C-10A | 129. Nut, MS21044C3 |
| 41. Liquid loading tube | 85. Nut, MS21044C4 | 130. Washer, MS15795-808 |
| 42. Hose assembly, MS28741-
20-0140 | 86. Washer, MS15795-808 | 131. Screw, MS24693-C279 |
| 43. Nut, MS20365-1032 | 87. Bolt, AN3C-10A | 132. Tank clamp |
| 44. Washer, AN960-10 | 88. Nut, MS21044C4 | 133. Tank support assembly |
| | 89. Washer, MS15795-808 | |

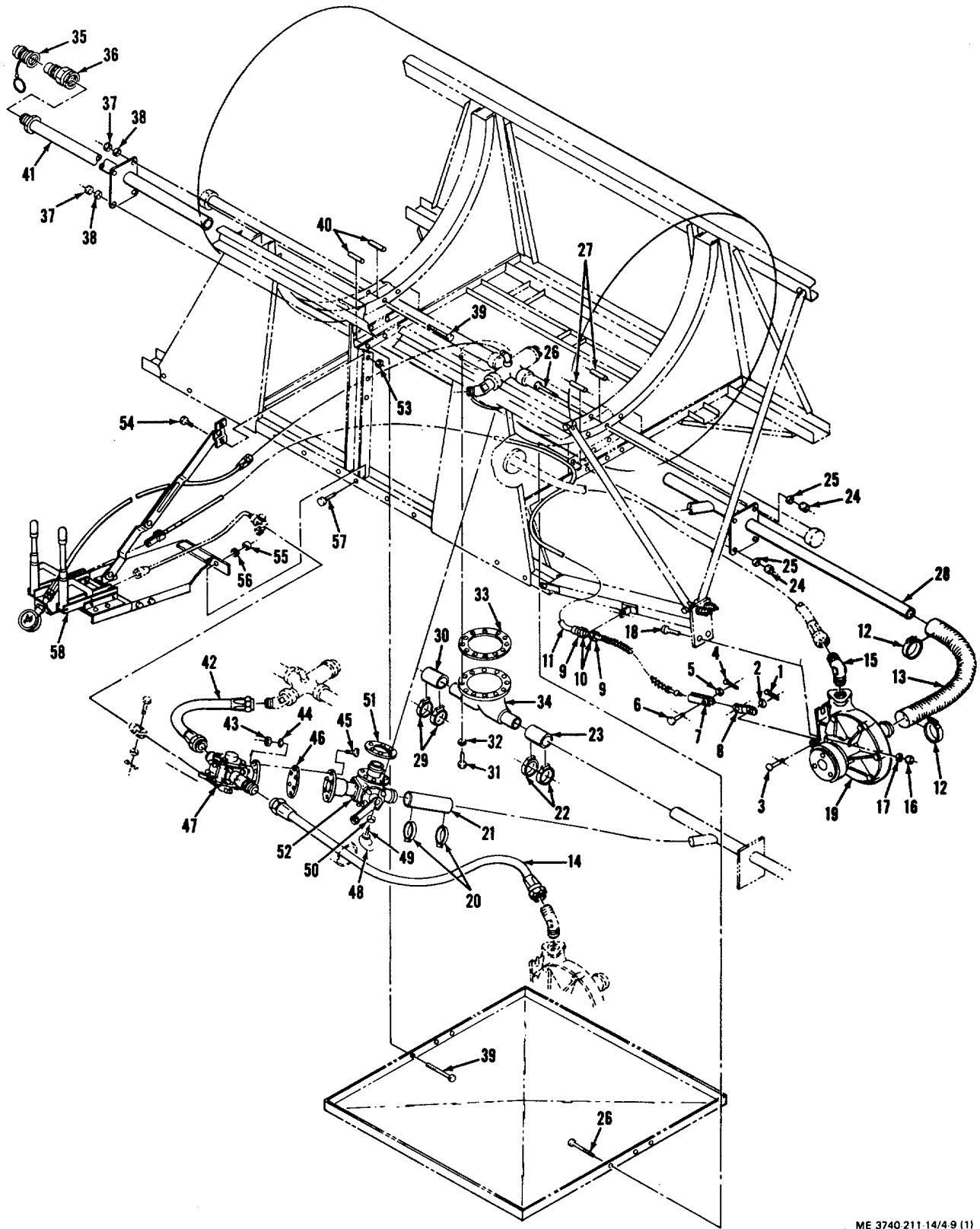

ME 3740 211-14/4-9 (1)

Figure 4-9. Tank Installation - exploded view.
4-19

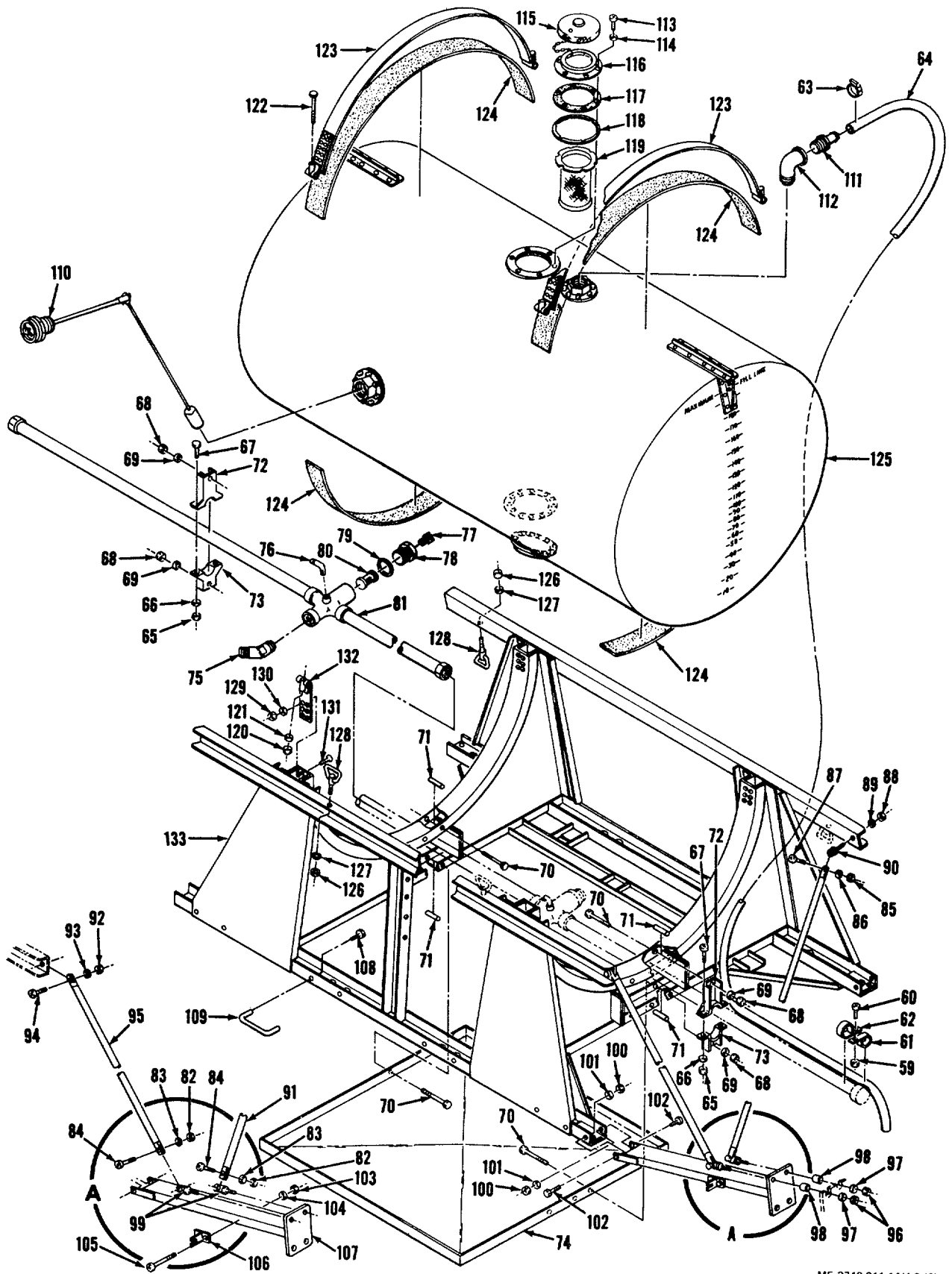

ME 3740-211-14/4.9 (2)

Figure 4-9. Tank Installation - exploded view.
4-20

4-15. Hoses

a. *General.* Three high-pressure hoses and four low-pressure hoses are used on the insecticide sprayer.

Refer to figure 4-9 and 4-10 for locations. The high-pressure hoses (14 and 42, fig. 4-9, and 22, fig. 4-10) are attached by MS28741 medium pressure, detachable end fittings. Low-pressure hoses (13, 21, 23, and 30, fig. 4-9) are attached by low-pressure hose clamps. A plastic tube is used as a tank vent and overflow tube. The plastic tube (64) is secured to the adaptor (111) with a low-pressure hose clamp. The other end is attached to the center boom tube by a pair of clamps (61 and 62).

b. *Maintenance and Adjustment.* Inspect hoses for condition and for security. Adjust high-pressure hoses to remove any kinks or twists. To do so, loosen hose end connections, or rotate mating connectors or elbows as required.

Note:

Threaded connectors must be rotated in a tightening direction only, as loosening may cause a leak. You may find it necessary to remove connectors and apply fresh teflon tape per Military Specification MIL-T-27730, to stop a leak.

c. *Removal.*

(1) Remove high-pressure hoses by unscrewing end fittings from mating connections.

(2) Remove low-pressure hoses by loosening hose clamps, and slipping hose ends from connections.

(3) Remove plastic overflow tube as follows (fig. 4-9):

(a) Loosen hose clamp (63) and slip end of tube (64) from adaptor (111).

(b) Remove nuts (59) and bolts (60) from clamps (61 and 62) securing tube to center boom tube.

(c) Remove clamps and black tape (placed around tubes beneath clamps) from both tubes.

d. *Cleaning and Inspection.* Clean interior and exterior portions of hoses and plastic tube to remove spray fluid residue, dirt, and other foreign matter.

Clean threads of high-pressure hose connectors.

Inspect condition of hoses, connectors, and hose clamps. Replace any hoses, connectors, or clamps found not serviceable.

e. *Installation.* Install hoses in same position from which removed. Replace any components found not serviceable. Clean mating connectors before installing to remove dirt, grease, tape, and other foreign matter. Install hoses as follows:

(1) High-pressure hoses. Apply a suitable lubricant to threads prior to installation of high pressure hoses.

Mate the connectors carefully to avoid stripping threads. Tighten connectors handtight only, using a wrench.

Adjust fittings so that no kinks or twists exist.

(2) Low-pressure hoses. Use tire soap to lubricate inside ends of low-pressure hoses. Place hose clamps over hoses before installing. Slip ends of hoses onto mating connections, and secure hose clamps using a screwdriver only.

(3) Plastic overflow tube. Install plastic overflow tube (64, fig. 4-9) to tank installation as follows:

(a) Install end of plastic tube over adaptor (111) at top of tank. Secure with hose clamp (63).

(b) Route tube over back of tank and around outside of tank support, to pump side of tank installation.

(c) Fasten tube to center boom tube (81) at approximately 2 inches inboard from boom tube coupling nut. Wrap 3/4-inch black electrical tape, or equivalent, around tubes at clamp locations. Place clamp (62) around center boom tube, and clamp (61) around plastic tube.

(d) Secure ends of clamps together, using bolt (60) and nut (59).

Note:

Insert screw through clamps from top.

4-16. Valved Nipple and Dust Cap

a. *General.* One valved nipple (36, fig. 4-9) with dust cap (35) is attached to the liquid loading tube (41). It forms the male half of a quick disconnect coupling used for connecting the ground liquid loading tube hose for loading operations. When disconnected, an internal valve closes, sealing off the liquid loading tube and preventing the tank from draining. The dust cap (35) is attached to the valved nipple body by a steel cable. The dust cap is used to protect the valved nipple from dust and other contaminants which might cause the valved nipple to leak.

b. *Maintenance.* Inspect the valved nipple and dust cap for leaks. Clean the valved nipple and dust cap to remove any foreign matter which may get caught in the valve and cause leakage.

c. *Removal.* Unscrew the valved nipple from the liquid loading tube using a wrench. Do not remove dust cap from valved nipple unless required for replacement.

d. *Installation.* Clean the threads of liquid loading tube. Wrap a thin layer of teflon tape per military specification- MIL-T-27730 around pipe threads. Tighten valved nipple to liquid loading tube with wrench.

4-17. Strainer

a. *General.* A strainer assembly (119, fig. 4-9) is located at the top of the tank assembly (125)

beneath the filler cap (115). Its use is to filter spray fluid when the tank is loaded from the top.

b. *Maintenance.* Remove filler cap (115) and inspect strainer and gaskets. If strainer is dirty, clogged, or damaged, or if gaskets are bad, remove faulty parts for cleaning or replacement.

c. *Removal* (fig. 4-9). Remove six screws (113) and washers (114), and filler flange (116) from top of tank. Remove gasket (117), filler (118), and strainer assembly (119). Detach cap chain from filler flange.

d. *Cleaning, Inspection and Repair.*

WARNING

Use air to maximum pressure of 25 psig. Avoid splashing insecticide fluid onto skin or into eyes. Observe precautions for handling poisonous fluids by flushing exposed areas with clean running water. Wash hands thoroughly with soap and water after handling and before eating or smoking.

(1) *Cleaning.* If spray fluid used in sprayer was water-base, clean the strainer by sloshing in clear water. If spray fluid used was oil-base, slosh in mineral oil. Use a stiff bristle brush, or low-pressure air to dislodge particles which cling to wire mesh.

(2) *Inspection.* Inspect all parts of strainer and cap assemblies. Check for condition of components, and replace defective or damaged parts.

(3) *Repair.* Repair or replace any part which does not pass inspection. Repair will consist mainly of straightening filler metal components. Replace torn gaskets or filler.

e. *Installation.* Install strainer in tank, using figure 4-9 and the following steps as guides:

Note:

Line up all attachment holes as required when installing parts.

(1) Place strainer assembly (119) in place, open end up.

(2) Place filler (118) around outside edges of strainer top flange.

(3) Place gasket (117) over strainer top flange and filler.

(4) Place filler flange (116) over entire assembly of parts.

(5) Secure parts with six washers (114) and screws (113).

(6) Attach safety chain from cap (115) to filler flange, and screw cap onto filler flange.

4-18. Control Valve

a. *General.* The control valve assembly (47, fig. 4-9) is a hand lever-controlled, ball type gate valve. It has three ports with connections to the pump outlet hose (14), spray boom inlet hose (42), and bypass valve (52). Its use is to control spray fluid flow during spraying operations. It is controlled by the valve lever (17, fig. 4-10). When the valve lever is in the VALVE CLOSED position, fluid is directed to the bypass valve. When in the VALVE OPEN position, fluid is directed to the spray booms.

b. *Maintenance and Adjustment.* Inspect valve and connections for condition and security of attachment. Adjust flow control screw (40, fig. 8-1) for back suction control. To adjust, turn flow control screw fully in to shut off back suction. Back screw off 2 to 2 1/2 turns for maximum back suction. Set the valve for maximum back suction.

Note:

The purpose of back suction is to draw fluid from spray booms when the control valve is in closed position. This prevents nozzles from dripping.

4-19. Bypass Valve

a. *General.* The bypass valve (52, fig. 4-9) is identical to the control valve (ref. para. 4-18), except for the end ports (fig. 8-1). The bypass valve inlet port is attached to the control valve (47, fig. 4-9).

The flanged outlet port is attached to the bottom of the tank assembly (125). The other outlet port is attached by hose to the pump inlet tube (28). The bypass valve is set to either open or closed position prior to flight. It is used to direct fluid from the control valve back to the tank (closed position) or back through the pump (open position).

b. *Maintenance and Adjustment.* inspect valve and connections for condition and security of attachment. Flow control screw (40, fig. 8-1) should be all the way in, as no back suction is required for the bypass valve.

SECTION VII. MAINTENANCE OF BOOM SPRAY SYSTEM

4-20. Spray Booms

a. *General* (fig. 6-1). Two spray boom assemblies are installed on the insecticide sprayer. Each boom has threaded holes for 30 spray nozzles. Vertical support of the spray boom is supplied by a boom support strut (15, fig. 4-2) and boom support cable (4, fig. 6-1). The strut and cable are attached to a bracket

attached to the top end of the tank assembly (fig. 4-2). Fore and aft motions of the spray boom are restricted by front and rear boom cables (21 and 22, fig. 6-1). These cables are attached to the lower channel rails of the tank support (fig. 4-2).

b. *Maintenance and Adjustment.*

(1) Adjust boom cables as described in paragraph 4-3, step a(7).

(2) Replace nozzles as described in paragraph 4-2, step a (1).

(3) Change nozzle orifice diameters by replacing spray tips (as described in para 4-5, step b (2)).

WARNING

Use air at maximum pressure of 25 psig. Avoid splashing insecticide fluid onto skin or into eyes. Observe precautions for handling poisonous fluids by flushing exposed areas with clean, running water. Wash hands thoroughly with soap and water after handling and before eating or smoking.

(4) Disassemble, clean, and inspect nozzles using figure 4-7 and the following steps as guides:

(a) Unscrew cap (1) from nozzle body assembly (8).

(b) Remove spray tip (2), and strainer assembly (3).

(c) Depress spring on nozzle body assembly (8) and unscrew retainer (4).

(d) Remove end cap assembly (5), secondary diaphragm (7), and diaphragm (6) from nozzle body assembly (8).

(e) Clean parts by sloshing in clear, running water (following use in water-base spray fluid) or mineral oil (following use with oil-base spray fluid).

Use low-pressure air to blow contaminants from parts.

(f) Inspect parts, and replace damaged components.

(5) Assemble nozzles, using figure 4-7 and the following steps as guides:

CAUTION

Do not overtighten nozzle parts.

(a) Place rubber diaphragm (6), teflon

secondary diaphragm (7) and end cap assembly (5) on nozzle body assembly (8), and secure with retainer (4), handtight only.

Note:

Teflon diaphragm (7) goes against body rubber diaphragm (6) against end cap assembly.

(b) Insert strainer assembly (3) and spray tip (2) into nozzle body assembly (8), and secure handtight with cap (1).

4-21. Center Boom

a. *General.* Center boom (81, fig. 4-9) is located within tank support assembly (133), beneath the tank assembly (125). Nuts on tube ends connect to spray booms. Tubes are welded to the strainer body.

Large elbow (75) is connected to hose (42) from control valve assembly (47). Small elbow (76) connects hose to pressure gage on manual control panel (58).

The strainer body contains screen assembly (80). Spray flow is strained and divided to the two spray booms in the strainer body.

b. *Maintenance*

(1) Inspect fluid connections, welded joints, cap (78), and gasket (79) for leakage. (2) Remove and clean or replace strainer and gasket, using figure 4-9 and the following steps as guides:

(a) Remove strainer cap (78), gasket (79), and screen assembly (80) from body or center boom (81).

Note:

Square plug in center of tap normal) does not need to be removed.

(b) Clean, inspect, and repair strainer screen and gasket in the manner described in paragraph 4-17, step d.

(c) Replace screen assembly (80) in body of center boom (81), and secure with gasket (79) and cap (78).

SECTION VIII. MAINTENANCE OF PUMP AND BRAKE ASSEMBLY

4-22. Pump Brake Cable

a. *General.* The pump brake cable assembly (11, fig. 4-9) is enclosed within a protective sheath over much of its length. The cable is attached to the brake lever on the manual control panel (58) and is routed out to the pump and brake assembly (19). When actuating the brake lever, the cable applies or releases the pump brake and thereby controls pump operation.

b. *Maintenance and Adjustment.* Adjust the cable for proper tension. With brake on, linkage at brake should be slightly slack, and the windmill must not be free to turn. With brake off, windmill must be free to turn, with no brake drag. Adjustment may be made by

combining the two following steps:

(1) Adjust jam nuts (9, fig. 4-9), which secure cable to bracket (106). Secure jam nuts firmly after adjustment.

(2) Rotate handle of brake lever (16, fig. 4-10) in direction required to tighten or loosen the cable.

c. *Removal.*

Note:

Observe routing and attachment points of brake cable as an aid to assembly.

(1) Remove cotter pin, washer, and clevis

pin (1, 2, and 3, fig. 4-10) to release brake cable from actuator of brake lever (16).

(2) Remove lower nut (4), washers (5), and screw (6) from bracket of brake lever (16), to release spacer (8) and cable housing clamp (9). Do not remove cable housing clamp from cable unless necessary for parts replacement.

(3) Loosen jam nuts (9, fig. 4-9) securing cable to bracket (106) on pump support assembly (107).

(4) Remove cotter pin (4), washer (5), and pin (6) securing cable to pump link (8).

(5) Remove cable from tank installation.

CAUTION

Use solvent in a well-ventilated area. Avoid breathing of fumes and excessive solvent contact with skin. Keep solvent away from open flame. Wash hands before smoking or eating.

d. Cleaning and Inspection. Clean cable of all dirt and other foreign matter by sloshing in cleaning solvent, Federal Specification P-D-680. Inspect cable for wear or damage.

e. Installation. Install pump brake cable on tank installation by routing in manner noted during removal.

Use figure 4-9 and the following steps as guides:

(1) Route cable over pump support assembly (107) and through tank support assembly (133) beneath the tank. End of cable with jam nuts on sheath goes toward pump.

(2) Attach cable end to pump link (8).

Secure with pin (6), washer (5), and cotter pin (4).

(3) Connect cable end to actuator of brake lever (16, fig. 4-10), using clevis pin (3), washer (2), and cotter pin (1).

(4) Secure cable housing clamp (9) and spacer (8) to bracket of brake lever (16), using screw (6), washers (5), and nut (4).

(5) Secure brake cable to bracket (106, fig. 4-1), using two washers (10) and jam nuts (9).

(6) Adjust cable as described in step *b*, preceding.

4-23. Synchronomatic Windmill Assembly

a. General. The synchronomatic windmill assembly (24, fig. 4-2) is attached to and drives the airborne pump. It consists of six adjustable, molded nylon blades mounted within two hub halves which contain an adjustment mechanism (fig. 7-1). Blade angles are set by turning the adjusting nut in the center of the windmill hub. The synchronomatic windmill assembly is turned by the slipstream while the helicopter is in forward flight.

b. Maintenance and Adjustment. Check blades for condition.

CAUTION

Nylon blade failures have occurred in hot, dry climates as a result of losing blade flexibility caused by loss of their natural moisture content. Therefore, at 30-day intervals, remove the blades from the hub assembly and place in boiling water for 30 minutes. This action is mandatory in all areas where humidity remains below 50 percent for extended periods of time.

(1) Remove blades from hub assembly as described in steps *c* and *d* following.

(2) Place blades in boiling water for 30 minutes to restore flexibility.

c. Removal (fig. 4-2). Remove three bolts (20) and remove synchronomatic windmill assembly (24) from brake drum (2, fig. 7-2).

d. Disassembly (fig. 7-1).

CAUTION

Do not disassemble cap hub assembly (1).

(1) Lift cap hub assembly (1) from base hub (3).

(2) Remove blades (2) from base hub. installation details for use during reassembly.

(3) Remove actuator (4) from adjusting screw (8).

e. Cleaning, Inspection, and Repair. Clean and inspect all parts of the synchronomatic windmill assembly as follows:

(1) Inspect all metal parts for nicks, scratches, corrosion, or other damage. Polish out minor defects using aluminum oxide abrasive cloth per Federal Specification P-C-451 for aluminum parts.

Use crocus cloth per Federal Specification P-C-458 for steel parts.

(2) Inspect all threaded parts for crossed or otherwise damaged threads and for damaged tool surfaces.

(3) Inspect blades for cracks, breaks, and stiffness.

Note:

Blades should be quite flexible. Check for stiffness by doubling blade tip over toward hub.

You should be able to bend blade tip over to almost touch itself.

(4) Replace all parts not meeting inspection requirements. Restore blade flexibility by placing blade in boiling water for 30 minutes, as in step *b*, preceding.

f. Assembly. Reassemble synchronomatic windmill assembly using figure 7-1 and the following steps as guides:

(1) Lightly oil bearing surfaces of base hub (3) with oil per Federal Specification VV-L-820.

(2) Install actuator (4) onto adjusting screw (8), with raised surface toward adjusting nut (6). Screw actuator onto adjusting nut until spoke ends are in line with lower surface of cap hub (9).

Note:

Approximately 34 inches of thread will protrude through the actuator.

(3) Install hubs of blades (2) into cap hub (9) with the retaining shoulder slots (10) of the blade hubs inserted over the spokes of the actuator (4). The blade hub retaining shoulder (11) should be fully seated in the cap hub bearing slots.

(4) With cap hub index aligned with base hub index, install base hub (3) onto cap hub assembly (1).

Note:

If synchromatic windmill assembly is not being installed on pump, secure parts together with bolt, washer, and nut (23, 22, and 21, fig. 4-2) placed through one mounting hole.

g. *Installation.* Install the synchromatic windmill assembly on the pump brake drum.

CAUTION

Do not overtighten bolts. Blade adjustment may be restricted, and undue stresses may be applied to hub assemblies.

(1) Place synchromatic windmill assembly against pump brake drum (2, fig. 7-2).

(2) Align holes and secure to brake drum with three new bolts (20, fig. 4-2).

Section IX. MAINTENANCE OF CONTROL SYSTEM

4-24. Manual Control Panel

a. *General.* The manual control panel (fig. 4-10) with its attached components, comprises most of the control system. Maintenance procedures for the pump brake cable are covered in paragraph 4-22. The control panel is attached to the tank support by hinges and a folding brace. This permits folding the control panel for installation and shipping. The control panel may be adjusted for installation into either the UH-1B or UH-1D helicopters (refer to para 4-3). Major components of the control panel include brake lever (16), valve lever (17), valve rod (15), pressure gage (21), and brake cable assembly (11, fig. 4-9).

b. *Maintenance and Adjustment.*

(1) Inspect the manual control panel and its components for security of attachment.

(2) Adjust brake cable assembly (21, fig. 9) for proper tension as described in para 4-22.

(3) Adjust linkage of valve lever (17, fig. 1-10), valve rod (15), and control lever of control valve assembly (47, fig. 4-9). Refer to paragraph

5-9, steps b(6) through b(9) for adjustment details.

(4) Inspect pressure gage (21, fig. 4-10) for condition and security of attachment. Replace gage if glass is broken, or if needle is bent or not at zero with no pressure applied. Tighten coupling (18) to secure pressure gage in position, facing aft.

(5) Inspect instruction plates (26) for condition and security of attachment. Replace if missing, loose, or if they cannot be read.

c. *Disassembly.* Remove components of control panel assembly as follows (fig. 4-10):

(1) *Levers.* Remove cotter pin (1), washer (2), and clevis pin (3) which attach brake cable assembly (11, fig. 4-9) or valve rod (15, fig. 4-10) to lever (16 or 17). Remove nuts (4), washers (5), and screws (6) and spacers (7 and/or 8) which secure lever (16 or 17) to control bracket (27). Remove assembly (and cable clamp housing (9) if removing brake lever (16).

Note:

Do not attempt to disassemble levers.

- | | |
|--------------------------------|--|
| 1. Cotter pin, MS34665-151 | 15. Valve rod: (for UH-1B, 25 in.) (for UH-1D, 36 in.) |
| 2. Washer, MS16795-810 | 16. Brake lever |
| 3. Clevis pin, MS9464-14 | 17. Valve lever |
| 4. Nut, MS16228-2 | 18. Coupling |
| 5. Washer, MS15795-812 | 19. Washer |
| 6. Screw, MS35307-341 | 20. Washer, rubber |
| 7. Spacer | 21. Gage |
| 8. Spacer | 22. Hose assembly |
| 9. Cable housing clamp | 23. Nut |
| 10. Cotter pin, MS34665-161 | 24. Screw, MS35308-307 |
| 11. Washer, MS15795-810 | 25. Support |
| 12. Clevis pin, MS9464-14 | 26. Instruction plate |
| 13. Lever clevis, 13216E5413-2 | 27. Control bracket |
| 14. Lever clevis, 13216E4313-1 | |

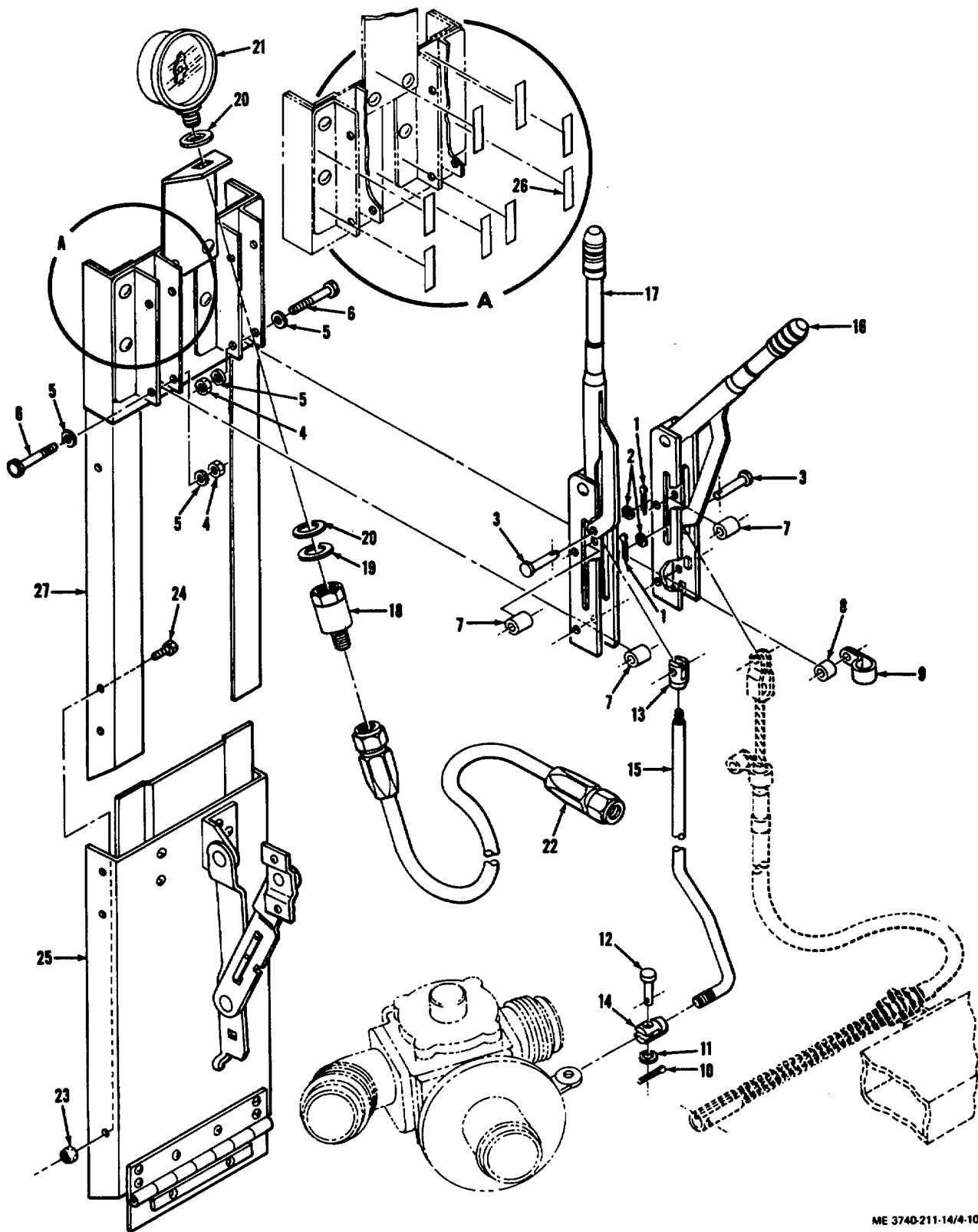

ME 3740-211-14/4-10

Figure 4-10. Manual control panel - exploded view.
4-27

(2) Valve rod (fig. 4-10). Remove cotter pin (1), washer (2), and clevis pin (3) which attach valve rod (15) to valve lever (17). Remove cotter pin, washer, and clevis pin (10, 11, and 12) to detach valve rod from lever of control valve (47, fig. 4-9). Remove valve rod, and remove lever devices (13 and 14, fig. 4-10) from ends of valve rod.

CAUTION

If pressure gage is not immediately replaced on pressure hose, cap or tape hose end to prevent entry of dirt or other foreign matter.

(3) Pressure gage (fig. 4-10). Detach hose assembly (22) from coupling (18) then remove coupling from gage (21). Remove washers (19 and 20) and pressure gage. Cap end of pressure gage and hose to prevent dirt entry.

d. Cleaning, Inspection, and Repair. Thoroughly clean all components of the control system to remove dirt, corrosion, or other foreign matter. Inspect each component and its attaching hardware for damage.

Discard components not considered usable.

e. Installation. Install components on manual control panel as follows (fig. 4-10):

Note:

Control valve lever has longer handle and slots in sides (4.5 inches) than brake lever.

(1) Brake lever (fig. 4-10). Place brake lever (16) in position on control panel. Line up holes, and place spacer (7) between sides of brake

lever bracket in upper position. Place spacer (8) and cable housing clamp (9) attached to brake cable in lower position. Secure parts with screws

(6), washers (5), and nuts (4). Attach brake cable end to actuator of brake lever with clevis pin (3), washer (2), and cotter pin (1).

(2) Valve lever (fig. 4-10). Place valve lever (17) in position on manual control panel. Line up holes, and place spacers (7) between sides of valve lever bracket. Secure parts with screws (6), washers (5), and nuts (4). Attach lever clevis (13) of valve rod (15) to actuator of valve lever with clevis pin (3), washer (2), and cotter pin (1).

(3) Valve rod (fig. 4-10). Screw lever clevises (13 and 14) onto each end of valve rod (15). Attach clevis at curved end of valve rod to control valve (47, fig. 4-9) using clevis pin, washer, and cotter pin (12, 11, and 10, fig. 4-10). Connect opposite end of valve rod to valve lever (17) as described in step (2), preceding. Turn valve handle as required to adjust control valve for proper operation. Refer to 5-9, steps b (6) through b (9) for details of adjustment.

(4) Pressure gage (fig. 4-10). Place washer (20) on threaded fitting of gage (21). Insert gage threaded fitting through square hole on top of manual control panel. Place washers (20 and 19) on threaded portion of gage. Wrap threads of gage with Teflon tape per Military Specification MIL-T-27730.

Secure coupling (18) to gage (21), and hose (22) to coupling.

**CHAPTER 5
DIRECT SUPPORT AND GENERAL SUPPORT
MAINTENANCE INSTRUCTIONS**

Section I. REPAIR PARTS, SPECIAL TOOLS AND EQUIPMENT

5-1. Tools and Equipment

Tools, equipment, and spare parts issued with or authorized for the aircraft-mounted insecticide sprayer are listed in the basic issue items list, appendix C.

5-2. Special Tools and Equipment

No special tools or equipment are required for

maintenance of the insecticide sprayer.

5-3. Maintenance Repair Parts

Repair parts and equipment covering Direct Support and General Support maintenance levels for the insecticide sprayer are listed and illustrated in TM 5-3740-211-24P.

Section II. TROUBLESHOOTING

5-4. Troubleshooting Chart

Table 5-1 lists troubleshooting steps for Direct Support and General Support maintenance level for the

insecticide sprayer. The chart serves only as a guide and does not preclude the chance that other troubles exist.

Section III. GENERAL MAINTENANCE

5-5. Removal of Components

Removal of major components, as described in section IV following, often requires removal of components authorized for removal by organizational maintenance level. When procedures are lacking for removal of parts, refer to pertinent paragraphs of chapter 4.

5-6. Hose Removal and Installation

Whenever removal of major components calls for

removal of hoses, use procedures given in paragraph 4-15, step c. When installation calls for attachment of hoses, use procedures given in paragraph 4-15, steps d and e. Clean all threaded connectors thoroughly. Use MIL-T-27730 teflon tape on all pipe threads. Use suitable thread lubricant on all tube fittings. Use tire soap on inside diameter of low-pressure hoses to aid in installation.

Table 5-1. Direct Support and General Support Troubleshooting Chart.

Malfunction	Probable cause	Corrective action
1. Tank support damaged.	Combat damage or improper handling.	Repair or replace damaged components (9-1/9-4).
2. Leaks in tank.	a. Holes or cracks. b. Severe damage or faulty seals.	a. Repair tank (8-12). b. Replace tank (8-9/8-14).
3. Couplings leak.	a. Foreign particles present. b. Faulty seals	a. Clean couplings. b. Replace coupling (8-6/8-8).
4. Leak develops in system installed in aircraft.	Faulty fluid system components.	Repair or replace faulty components.
5. Use of pump causes vibration.	Pump bearings faulty.	Replace pump bearings (7-11/7-16).
6. Pump leaks through weep holes.	Seals faulty	Replace seals (7-11/7-16).
7. No response to spray command.	a. Faulty control valve. b. Pump brake sticks.	a. Replace or repair control valve (8-1/8-5). b. Replace brake cable (4-22) or repair pump brake (7-7/7-10).
8. No response to stop spray command.	a. Faulty control valve. b. Pump brake sticks.	a. Remove and repair control valve (8-1/8-5). b. Replace brake cable (4-22) or remove and repair pump brake (7-7/7-10).
9. Spray intermittent.	Faulty synchromatic windmill pump drive.	Remove and repair pump and brake assembly and windmill assembly as required (7-2/7-16).
10. Spray uneven.	Faulty pump.	Remove and repair pump (7-11/7-16).
11. Unable to adjust windmill blade angle.	Synchromatic windmill internal mechanism - damaged.	Remove and repair synchromatic windmill assembly (7-2/7-6).

5-7. Drip Pan Removal

When working on components located beneath the tank, you may find it convenient to remove the drip pan (74, fig. 4-9). This will provide you with easy access to components.

WARNING

A minimum of two men are required to tilt the tank installation. Always block the tank installation to prevent its falling.

CAUTION

Lift tank installation by handles, never by booms or braces.

a. **Tilting Tank Installation.** Carefully tilt the tank installation backward unless it rests on the back frame of the tank support. Place blocking material of sufficient size and strength beneath the tank support frame to hold tank installation in tilted position.

b. **Removal of Drip Pan.** Remove drip pan (74) from tank installation as follows, using figure 4-9 and the following steps as guides:

(1) Remove lower nuts (24, 37, and 68), washers (25, 38, and 69), screws (26, 39, and 70) and spacers (27, 40, and 71) that secure drip pan to tank support assembly (133).

Note:

Attaching hardware also secures bottom portions of tube flanges of pump inlet tube (28), liquid loading tube (41), and tube lower clamps (73) to tank support assembly.

(2) Remove drip pan.

c. **Installation of Drip Pan.** Install drip pan beneath tank using figure 4-9 and the following steps as guides:

(1) Line up all mounting holes of drip pan (74) with mating holes in lower channel of tank support assembly (133).

CAUTION

Spacers (27, 40, and 71) are placed with in tank support channel at each attachment hole used for securing drip pan, tube flanges, and tube clamps to tank support. When inserting bolts, be sure bolt passes through spacers.

Insert screw head from inside of tank support with washers and nuts on outside of tank support.

(2) Insert spacers (27, 40, and 71) within channel and in line with mounting holes.

(3) Insert screws (26 and 39) from inside drip pan, through the following components: lower channel of tank support assembly (133); spacers (27 and 40); lower holes in mounting flanges of liquid loading tube (41), and pump inlet tube (28). Secure components with washers (25 and 38) and nuts (24 and 37).

(4) Insert screws (70), from inside drip pan, through the following components; lower channel of tank assembly (133); spacers (71), and lower tube clamp (73). Secure components with washers (69) and nuts (68).

Section IV. REMOVAL AND INSTALLATION OF MAJOR COMPONENTS

5-8. Pump and Brake Assembly

a. Removal.

(1) If synchromatic windmill assembly (24, fig. 4-2) is not removed from pump and brake assembly (19, fig. 4-9), remove as instructed in paragraph 4-23, step c. Disconnect inlet and outlet hoses (13 and 14) from pump and brake assembly as instructed in paragraph 4-15.

(2) Disconnect brake cable assembly (11, fig. 4-9) by removing cotter pin (1), washer (2), and clevis pin (3). Disengage pump link (8) from brake actuation lever of pump and brake assembly (19). Disconnect outlet hose (14) and inlet hose (13) from pump and brake assembly.

(3) Remove pump and brake assembly from pump support assembly (107) using figure 4-9 and the following steps as guides:

(a) Remove two bottom nuts (16), washers (17), and screws (18).

(b) Loosen and back off two upper nuts (96) as required to permit slipping pump and brake assembly from pump support assembly (107). Do not remove nuts as they secure the pump support assembly

in position.

(c) Remove pump and brake assembly from pump support assembly.

(4) Remove elbow (15) from outlet port of pump and brake assembly.

b. Installation.

(1) Attach pump and brake assembly (19) to pump support assembly (114) using figure 4-9 and the following steps as guides:

(a) Loosen nuts (96) at top of pump support assembly enough to permit slipping foot of pump and brake assembly (19) over bushings (98).

(b) Slip upper slots in foot of pump and brake assembly over bushings.

(c) Insert screws (18) through lower holes in pump support assembly (107) and through slots in foot of pump and brake assembly. Place washers (17) and nuts (16) over screws.

(d) Secure all upper and lower nuts (96 and 16).

(2) Install elbow (15) in outlet port of pump and brake assembly after wrapping threads with Teflon tape per MILT-27730. Attach high pressure hose (14) as instructed in paragraph 5-6. Orient elbow to provide the least possible amount of bending, kinking, or twisting of the hose.

(3) Attach inlet hose (13) to inlet port of pump and brake assembly, and secure with hose clamps (12).

(4) Connect brake cable assembly (11) by attaching the pump link (8) to the brake actuation lever.

Use clevis pin (3), washer (2), and cotter pin (1) to secure parts.

5-9. Control Valve Assembly

Note:

To gain access to components, consider tilting tank installation and remove drip pan (para 5-7).

a. Removal. Remove control valve assembly (47, fig. 4-9) as follows:

(1) Remove cotter pin, washer, and clevis pin (10, 11, and 12, fig. 4-10), securing valve rod (15) to control lever of valve assembly.

(2) Unscrew end fittings of high-pressure hoses (14 and 42, fig. 4-9) from valve connectors.

(3) Remove nuts (43), washers (44), and bolts (45) attaching control valve assembly to bypass valve assembly (52).

(4) Remove control valve assembly and gasket (46) from sprayer system.

b. Installation. Install control valve assembly as follows:

(1) Place gasket (46) on flange of bypass valve assembly (72). Attach control valve assembly to bypass valve assembly, and secure with bolts (45), washers (44), and nuts (43).

(2) Attach high-pressure hoses (14 and 42) to control valve assembly (ref para 5-6).

(3) Place manual control panel (58) in extended position.

(4) Turn handle of valve lever (17, fig. 4-10) all the way in (clockwise).

(5) Place valve control lever in closed position. Loosen nut (1, fig. 8-1) to loosen lever (4) on shaft of valve ball (38).

(6) With valve lever (17, fig. 4-10) on control panel in VALVE CLOSED position, connect valve rod (15) to valve lever (4, fig. 8-1). Turn lever as needed to properly align parts. Secure lever clevis (14, fig. 4-10) on valve rod to valve lever with clevis pin, washer, and cotter pin (12, 11, and 10, fig. 4-10).

(7) Secure nut (1, fig. 8-1) on lever (4).
(8) Test valve for actuation and proper adjustment by actuating valve lever (17, fig. 4-10) several times.

Valve must be in closed position when valve lever is in VALVE CLOSED position, and in open position when

valve lever is in VALVE OPEN position. If further adjustment is required, repeat portions of steps 5, 6, and 7, preceding, as required.

(9) When lever is properly adjusted, disconnect valve rod (15, fig. 4-10) from lever. Secure attaching parts to lever. Lay end of valve rod in drip pan, and fold control panel to its retracted position.

Note:

Control panel must be in retracted position before loading sprayer into helicopter.

5-10. Liquid Loading Tube

Note:

To gain access to components, consider tilting tank installation and removing drip pan (para 5-7).

a. Removal. Remove liquid loading tube from tank installation using figure 4-9, and the following steps as guides:

(1) Loosen hose clamps (29) and hose (30) connecting liquid loading tube (41) to sump (34).

(2) Remove four nuts (37), washers (38), screws (39) and spacers (40) securing liquid loading tube to tank support assembly (133).

(3) Remove liquid loading tube.

(4) If required, remove valved nipple (36) with dust cap (35) from liquid loading tube.

b. Installation. Install liquid loading tube to tank installation using figure 4-9 and the following steps as guides:

(1) Place liquid loading tube (41) into position through opening in tank support assembly (133) under tank assembly (125).

(2) Using procedure of paragraph 4-15, step e (2) for installing low-pressure hoses, insert end of liquid loading tube into low-pressure hose (30) attached to sump (34). Secure with hose clamps (29).

Note:

if drip pan was removed, replace drip pan as instructed in paragraph 5-7, step c.

(3) Line up attachment holes in mounting flange of liquid loading tube with holes in lower channel of tank support assembly (133). Place spacers (40) between sides of tank support channels and in line with mounting holes. Insert screws (39) through drip pan, channel, spacers, and mounting flange of liquid loading tube. Secure with washers (38) and nuts (37).

5-11. Pump Inlet Tube

Note:

To gain access to components, consider tilting tank installation and removing drip pan (para 5-7).

a. Removal. Remove pump inlet tube from tank installation using figure 4-9, and the following steps as guides:

(1) Loosen hose clamp (12) and remove pump inlet hose (13) from outlet end of pump inlet tube (28).

(2) Loosen hose clamps (20) and hose (21) connected between bypass valve assembly (32) and wye stub of pump inlet tube (28).

(3) Loosen hose clamps (22) and hose (23) connected between sump (34) and inlet end of pump inlet tube (28).

(4) Remove four nuts (24), washers (25), screws (26), and spacers (27) securing pump inlet tube to tank support assembly (133). (5) Remove pump inlet tube.

b. Installation. Install the pump inlet tube to tank installation using figure 4-9 and the following steps as guides:

(1) Place pump inlet tube (28) into position through opening in tank support assembly (133) under tank assembly (125). Curved end of tube goes outboard, facing up and forward.

(2) Use procedure of paragraph 4-15, step *e* (2) to install low-pressure hoses. Insert inlet end of pump inlet tube into hose (23) connected to sump (34). Secure hose with tube clamps (22). Insert wye stub tube end of pump inlet tube into hose (21) connected to bypass valve (52). Secure with hose clamps (20).

Note:

If drip pan was removed, replace drip pan as instructed in para 5-7, step *c*.

(3) Line up attachment holes in mounting flange of pump inlet tube with holes in lower channel of tank support assembly (133). Place spacers (27) between sides of tank support channels, in line with mounting holes. Insert screws (26) through dip pan, channel, spacers, and mounting flange of pump inlet tube. Secure with washers (25) and nuts (24).

(4) Use procedure of 4-15, step *e* (2) to install low-pressure hoses. Slip pump inlet hose (13) over outlet end of pump inlet tube. Secure with hose clamp (12).

5-12. Bypass Valve Assembly

a. Removal. Remove bypass valve assembly (52, fig. 4-9) as follows:

Note:

Refer to paragraph 8-11, step *c* for instructions for removal of bypass valve assembly with tank assembly (125) removed from tank support (133). To gain access to components with tank assembly installed to tank support, consider tilting tank installation and removing drip pan (para 5-7).

(1) Remove control valve (para 5-9, step *a*).

(2) Remove pump inlet tube (28) as instructed in paragraph 5-11, step *a*.

(3) Remove and discard lockwire (48) and

remove six bolts (49) and washers (50) that secure bypass valve assembly to tank connector.

(4) Loosen hose clamps (20) and remove low-pressure hose (21) from bypass valve assembly outlet port.

(5) Remove bypass valve assembly and gasket (51) from tank connector.

b. Installation. Install bypass valve assembly (52, fig. 4-9) as follows:

(1) Using procedure of paragraph 4-15, step *e* (2) for installing low-pressure hoses, install hose (21) to bypass valve outlet port. Secure with hose clamp (20).

(2) Install bypass valve assembly as instructed in paragraph 8-13, step *a*(3).

(3) Install pump inlet tube (28) to tank installation as instructed in paragraph 5-11, step *b*.

(4) Install control valve assembly (47, fig. 4-9) as instructed in paragraph 5-9, step *b*.

(5) If drip pan was removed, replace drip pan as instructed in paragraph 5-7, step *c*.

5-13. Center Boom Assembly

Note:

To gain access to components, consider tilting tank and removing drip pan (ref para 5-7).

a. Removal. Remove center boom (81, fig. 4-9) using the following steps as guides:

(1) Remove overflow tube (64) from tank installation as described in paragraph 4-15, step *c*(3).

(2) Remove liquid loading tube (41) from tank installation as described in para 5-10. Do not remove valved nipple (36) with dust cap (35) unless necessary for replacement.

(3) Disconnect hoses to control valve assembly (47) and pressure gage (21, fig. 4-10).

(4) Remove nuts (65, fig. 4-9), washers (66), and screws (67) which secure upper clamp (72) and lower clamp (73) together at each end of the tank support assembly (133).

(5) Remove nuts (68), washers (69), screws (70), and spacers (71) securing upper and lower clamps to tank support. Remove upper and lower clamps.

(6) Remove center boom (81) from tank installation through the opening in right-hand side of tank support (looking forward). Note position of center boom as an aid during installation.

(7) Remove elbows (75 and 76) from body of center boom.

(8) Remove cap (78), gasket (79), and screen assembly (80) from body. Do not remove plug (77) from cap unless it needs to be replaced.

b. Installation. Install center boom in tank installation, using figure 4-9 and the following steps as guides:

(1) Install screen assembly (80) in body of center boom (81), and secure with gasket (79) and cap (78).

(2) Wrap threads of elbow (75) with teflon tape per Military Specification MIL-T-27730. Install elbow into body of center boom.

(3) With liquid loading tube (41) removed from tank installation, insert end of center boom through opening at bottom of tank support assembly (133).

Note:

Insert tube so that cap of screen assembly faces aft and pressure sensing hole in screen assembly body is up.

(4) Position body of center boom midway between ends of tank support assembly. Install upper clamps (72) to tank support channels using spacers (71), screws (70), washers (69), and nuts (68).

(5) Attach lower clamps (73) to upper clamps with center boom tubes between clamps halves. Install screws (67) with heads up, washers (66), and nuts (65) to hold clamps together. Do not secure tightly at this time.

(6) Attach hose assembly (42) from control valve to large elbow and secure (ref para 5-6). Adjust hose and elbow (75) as required to remove any kinks or twists.

(7) Install liquid loading tube (41) and secure (para 5-10, step b).

(8) Adjust center boom to position screen assembly body midway between tank support ends. Rotate center boom as required to eliminate any kinks in hose assembly (42) to control valve. Secure nuts (65) to secure upper and lower clamps.

Note:

If drip pan is removed, delay final adjustment of center boom until drip pan is replaced (ref para 5-7).

(9) Wrap threads of elbow (76) with teflon tape per Military Specification MIL-T-27730. Install elbow into screen assembly body. Attach hose from pressure gage on manual control panel (58).

(10) Install overflow tube (64) to tank installation and secure as described in paragraph 4-15, step e(3).

5-14. Liquid Level Gage

a. Removal. Tilt tank for vertical removal of liquid level gage to avoid baffles and damage to mechanism. Remove liquid level gage (110, fig. 4-9) from tank assembly by unscrewing gage in counterclockwise direction. Use care not to damage gage or its attached float.

b. Installation. Install liquid level gage to tank assembly using figure 4-9 and the following steps as guides:

- (1) Cover threads of liquid level gage (110)

with teflon tape per Military Specification MIL-T-27730.

(2) Tilt tank to permit vertical installation of liquid level gage. Insert float end of gage into tank, and carefully attach gage to its mounting flange. Turn gage in a clockwise direction to attach.

(3) Make final adjustment of gage to place "1/2" mark at top.

5-15. Sump

Note:

To gain access to components, consider tilting tank installation and removing drip pan (ref para 5-7).

a. Removal. Remove sump (34, fig. 4-9) from bottom of tank, using figure 4-9 and the following steps as guides:

(1) Loosen clamps (29 and 22), and remove hoses (30 and 23) connecting sump to liquid loading tube (41) and pump inlet tube (28). Remove hoses per instructions of paragraph 4-15, step c(2).

(2) Remove 12 screws (31) and washers (32) securing sump to bottom of tank.

(3) Remove sump and gasket (33) from tank.

b. Installation. Install sump (34) to tank, using figure 4-9 and the following steps as guides:

(1) Coat new gasket (33) and screws (31) with Tite-seal gasket and joint compound, part no. T3504 or equivalent. (Non-hardening sealant may be used on gasket surfaces).

(2) Place gasket (33) on flange of sump (34) with mounting holes aligned.

(3) Place sump into position under tank, with end ports pointing toward ends of tank.

(4) Attach sump to tank with 12 washers (32) and screws (31). Secure screws handtight.

(5) Reconnect hoses (30 and 23) to liquid loading tube (41) and pump inlet tube (28). Install hoses per instructions of paragraph 4-15, step e(2). Secure hoses with clamps (29 and 22).

5-16. Tank Assembly

a. Removal. Remove tank assembly from tank installation using the following steps as guides:

(1) Remove liquid loading tube (41, fig. 4-9) from tank installation as instructed in paragraph 5-10, step a.

(2) Remove pump inlet tube (28) from tank installation as instructed in paragraph 5-11, step a.

(3) Loosen hose clamps (20) and hose (21) at outlet port of bypass valve assembly (52).

(4) Remove cotter pin (10, fig. 4-10), washer (11), and clevis pin (12) securing valve rod

(15) to control lever of control valve assembly (47, fig. 4-9).

(5) Unscrew end fittings of high-pressure hoses (14 and 42) from connectors of control valve assembly (47).

(6) Remove overflow tube (64) from tank installation as described in paragraph 4-15, step c(3).

(7) Remove nuts (120), washers (121), and screws (122) securing tank strap assemblies (123) to tank clamps (132). Remove tank strap assemblies and upper cushions (124).

CAUTION

A minimum of two men are required to remove tank assembly from tank support assembly.

(8) Carefully lift tank assembly (125) from tank support assembly (133). Remove cushions (124) from cradle channels of tank support assembly only if they are damaged and need to be replaced.

These are cemented in.

(9) Remove components from tank assembly only if required. Refer to paragraph 8-11 for instructions.

b. Installation. Install tank assembly in tank support using figure 4-9 and the following steps as guides:

(1) Check condition of felt cushion (124) on cradle channels of tank support assembly (133). Replace with new cushions if necessary, as instructed in paragraph 9-8, step c(3).

(2) Replace any components removed from tank as instructed in paragraph 8-13.

CAUTION

A minimum of two men are required to lift the tank assembly. Exercise care in placing tank assembly in tank support assembly.

(3) Carefully lift tank assembly (125) and install in tank support assembly (133). Liquid level gage (110) faces forward. Center tank sump between tank support cradle channels. Rotate tank as required to place sump directly on bottom.

Note:

Leave tank strap assemblies loose so that tank may be rotated for alignment of connections.

(4) Attach tank assembly (125) loosely to tank support assembly (133) with tank strap assemblies (123). Place upper half of cushions (124) beneath tank straps, and connect tank straps to tank clamps (132) with screws (122).

Attach with washers (121) and nuts (120).

Note:

At least two threads of screws (122) must show through attaching nut (120)

(5) Connect overflow tube (64) to tank installation and secure as described in para 4-15, step e(3).

(6) Install hose (21) between outlet port of bypass valve (52) and wye stub of pump inlet tube (28). Secure with hose clamps (20) (ref para 5-6).

(7) Attach high-pressure hoses (14 and 42) to control valve assembly (ref para 5-6).

(8) Install pump inlet tube (28) as instructed in paragraph 5-11, step *b*.

(9) Install liquid loading tube (41) as instructed in paragraph 5-10, step *b*.

(10) Attach valve rod (15, fig. 4-10) to control valve assembly (47, fig. 4-9) and adjust as described in 5-9, steps *b*(6) through *b* (9).

(11) Tighten nuts (120) attaching tank (123) to tank clamps (132).

5-17. Manual Control Panel

a. Removal. Remove manual control panel (58, fig. 4-9) from tank support assembly (133), using figure 4-10 and the following steps as guides:

(1) Remove cotter pins (1), washers (2), and clevis pins (3) from brake and valve levers (16 and 17) to disconnect brake cable assembly (11, fig. 4-9) and valve rod (15, fig. 4-10) from lever actuators. Remove lower nut (4), washers (5), and screw (6) from bracket of brake lever (16). Remove spacer (8) and brake cable assembly (11, fig. 4-9). Remove cable housing clamp (9, fig. 4-10) from brake cable assembly if necessary for replacement.

(2) Detach hose assembly (22) from pressure gage (21) by unscrewing pressure gage line from coupling (18). Leave coupling attached to pressure gage to retain parts in position. Cap pressure gage hose assembly to prevent dirt entry.

(3) Remove two nuts (53, fig. 4-9) and screws (54) retaining folding brace of manual control panel (58) to center brace of tank support assembly (133).

(4) Remove nuts (55), washers (56), and screws (57) securing manual control panel hinge to tank support assembly (133). Remove manual control panel from tank support assembly.

(5) Do not remove components from manual control panel unless necessary. Refer to paragraph 4-24, step *c* for instructions.

b. Installation. Install manual control panel on tank support assembly using figure 4-9 and the following steps as guides:

(1) Attach hinge of manual control panel (58) to tank support assembly (133), using screws (57) washers (56), and nuts (55).

(2) Attach folding brace of manual control panel to center brace of tank support assembly, using screws (54) and nuts (53).

Note:

Folding braces may be attached to either the upper or lower pair of holes in tank support center brace. Use upper holes for UH-1B installation, and lower holes for UH-1D installation (ref para 4-3).

(3) Attach hose assembly (22, fig. 4-10) to

coupling (18).

(4) Attach brake cable assembly (11, fig. 4-9) to brake lever (16, fig. 4-10) and valve rod (15) to valve lever (17). Place clevis pins (3) through slots in lever sides, connecting cable and lever clevis (13) to actuation arm of lever. Place washers (2) over clevis pins, and secure with cotter pins (1).

(5) Reattach cable housing clamp (9) and spacer (8) to brake lever position on control panel using screw (6), washers (5) and nut (4).

CHAPTER 6 REPAIR OF BOOM SPRAY SYSTEM

Section I. SPRAY BOOM REMOVAL AND DISASSEMBLY

6-1. General

Two spray boom assemblies are attached to the tank installation (fig. 4-2). Each spray boom assembly consists of a boom tube with nozzles evenly spaced along the length of the tube. Cables and braces attached to the boom provide support. The boom tubes are connected to the center boom of the tank installation with tube type fittings. Direct Support and General Support maintenance of the boom spray system is described in this chapter.

6-2. Removal

Remove spray boom assemblies from tank installation as described in paragraph 4-4, step a(2).

6-3. Disassembly

Disassemble spray boom assemblies using the following steps as guides:

a. Remove nozzles (16, fig. 4-2), nipples (17), elbows (18), and plugs (32) from spray boom assembly (19).

b. Disconnect cable assemblies from outboard tube clamps, and remove tube clamps using figure 6-1 and the following steps as guides:

(1) Remove nut (1), washer (2), and bolt (3), and remove upper boom support cable (4) from top tube clamp half (12).

(2) Remove nuts (5) and washers (6) from short bolts (7) on top tube clamp half (12). Remove bolts (7) to release ends of long front and rear boom cables (21 and 22) from top tube clamp half.

(3) Remove four nuts (8) and washers (9) from long bolts (10) holding top and bottom tube clamp halves (12 and 13) together.

(4) Remove bolts, links (11), top and bottom clamp halves, and two ring halves (14) from boom tube (32).

- | | | | |
|-----|-----------------------|-----|-----------------------|
| 1. | Nut, MS21044C4 | 17. | Bolt, AN3C-10A |
| 2. | Washer, MS15795.810 | 18. | Nut, MS21044C3 |
| 3. | Clevis bolt, AN24-18A | 19. | Washer, MS15795-808 |
| 4. | Boom support cable | 20. | Clevis bolt, AN23-14A |
| 5. | Nut, MS21044C3 | 21. | Front boom cable |
| 6. | Washer, MS15795-808 | 22. | Rear boom cable |
| 7. | Clevis bolt, AN23-14A | 23. | Nut, MS21044C3 |
| 8. | Nut, MS21044C3 | 24. | Washer, MS15795-808 |
| 9. | Washer, MS1579&-808 | 25. | Clevis bolt, AN3-22A |
| 10. | Clevis bolt, AN3-22A | 26. | Boom brace |
| 11. | Link | 27. | Link |
| 12. | Tube clamp | 28. | Tube clamp |
| 13. | Bottom tube clamp | 29. | Bottom tube clamp |
| 14. | Half ring | 30. | Half ring |
| 15. | Nut, MS21044C3 | 31. | Plug |
| 16. | Washer, MS15795-808 | 32. | Boom tube |

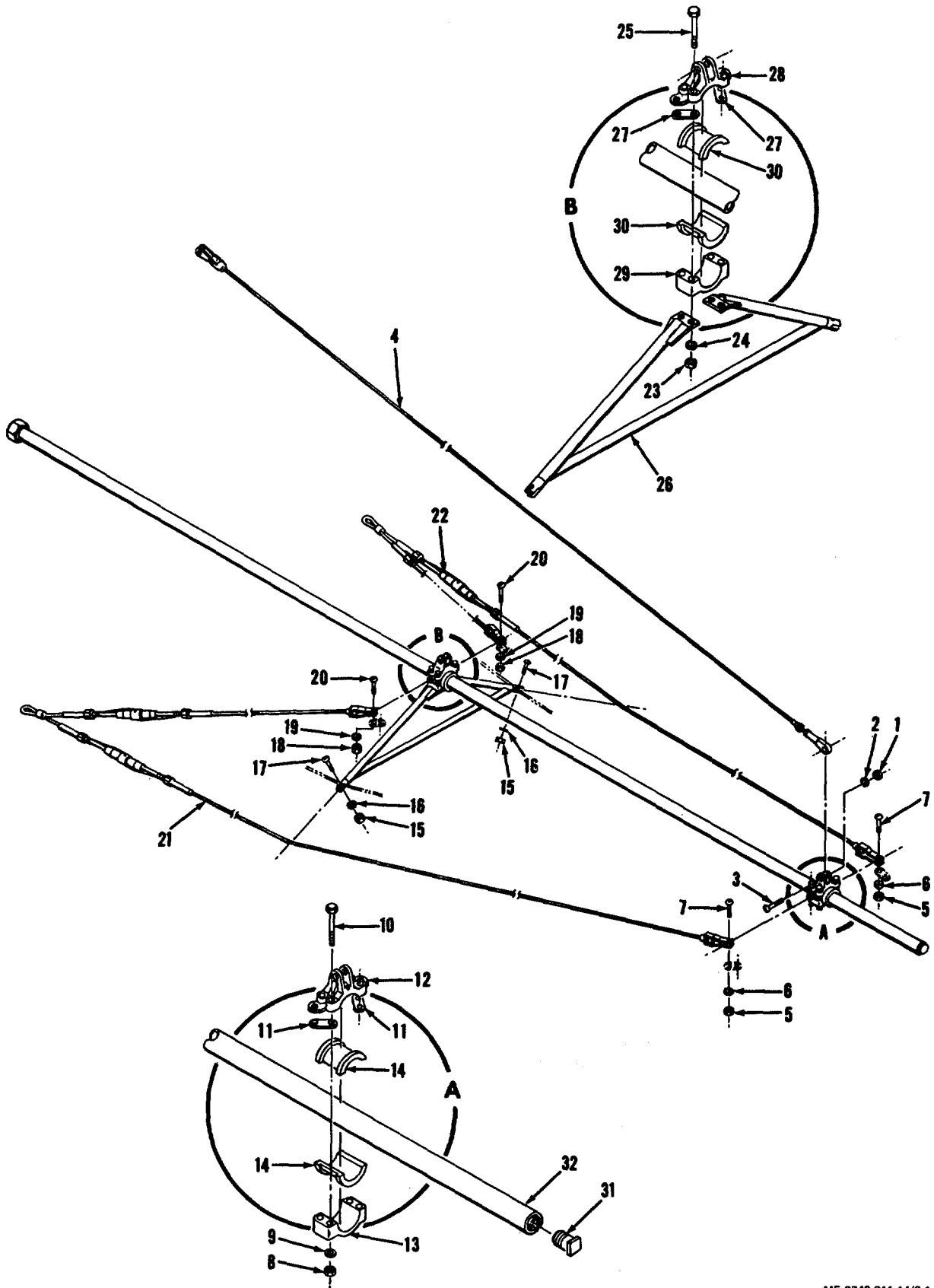

ME 3740-211-14/6-1

Figure 6-1. Spray boom assembly – exploded view.

c. Remove nuts (15), washers (16) and bolts (17) from slotted ends of boom brace (26), and remove cable from slots.

d. Disconnect cable assemblies from inboard tube clamps, and remove tube clamps using figure 6-1 and the following steps as guides:

(1) If boom support strut (15, fig. 4-2) is not yet removed, remove per instructions of paragraph 4-4, step a (2) (f).

(2) Remove nuts (18, fig. 6-1) and washers (19) from short bolts (20) on top tube clamp half (28).

Remove bolts (20) to release ends of short cables of front and rear boom cables (21 and 22) from top tube clamp half.

(3) Remove four nuts (23) and washers (24) from long bolts (25) securing boom brace (26) and holding top and bottom tube clamp halves (28 and 29) together. Remove bolts (25), boom brace (26), links (27), top and bottom tube clamps halves, and two ring halves (30) from boom tube (32).

e. Remove plug (31) from end of boom tube (32).

Section II. CLEANING, INSPECTION, AND ASSEMBLY

6-4. Cleaning

Clean boom tubes thoroughly to remove buildup of spray fluid, dirt, and other contaminants. Clean threads of all nozzle attachment holes, and of tube end fittings. Clean threads of nipples, elbows, and nozzles. Clean nozzles as described in paragraph 4-20, step b (4).

6-5. Inspection

Inspect all components of the spray boom assembly. Check all threaded parts for crossed or otherwise damaged threads. Check boom tubes (32, fig. 6-1) and tube clamp halves (12, 13, 28 and 29) for cracks, bends, or distortion. Check cables (4, 21, and 22) for damage, fraying, or corrosion. Check cable ends and slots in boom brace (26) for damage. Discard any parts which are not usable.

6-6. Assembly

Assemble the spray boom assemblies using figure 6-1 and the following steps as guides:

a. Assemble nozzles (16, fig. 4-2) as described in paragraph 4-20, step b (5).

b. Install nozzles into boom tube as described in paragraph 4-2, step a (1).

c. Install plug (31, fig. 6-1), into end of boom tube (32).

d. Attach tube clamp assemblies to boom tube. Locate tube clamp assemblies between 18th and 19th, and between 4th and 5th nozzles from outboard (plug) end of boom tube. Using the following steps as a guide:

(1) Place ring halves (14 or 30) on top and bottom of tube.

(2) Place top tube clamp half (12 or 28) over ring half on top of tube, and bottom tube clamp half (13 or 29) over ring half on bottom side of tube.

(3) Place four long bolts (10 or 25) through tube clamp halves from top side. The bolts on outboard side of tube clamps go through one hole of links (11 or 27).

(4) On inboard tube clamps only, install boom brace (26) under bottom tube clamp half (29).

Note

Long arm of boom brace faces forward

(5) Secure components with washers (9 or 24) and nuts (8 or 23).

e. Attach front and rear boom cable assemblies (21 and 22) to upper tube clamp halves (12 and 28) noting the following:

(1) Overall length of front boom cable (21) is about 1 inch longer than length of rear boom cable (22).

(2) Place long boom cable in slots in boom brace (26). Hold in place by inserting bolts (17) from top down, and secure with washers (16) and nuts (15).

(3) Attach long and short boom cables to outer holes in upper tube clamp halves (12 or 28) Insert short bolts (7 or 20) from top down, and secure with washers (6 or 19) and nuts (5 or 18). On forward side of each top tube clamp (12 and 28). The bolts pass through links (11 or 27).

f. Attach upper boom support cable (4) to outboard tube clamp upper half (12). Use bolt (3), washer (2), and nut (1) to secure.

CHAPTER 7 REPAIR OF PUMP AND BRAKE ASSEMBLY

Section I. SYNCHROMATIC WINDMILL ASSEMBLY

7-1. General

The synchromatic windmill assembly (fig. 7-1) is a six-blade, adjustable pitch fan which is attached directly to the pump and brake assembly (19, fig. 4-9). The windmill assembly is operated by the airstream as the helicopter moves forward in flight. It provides the power required to pump insecticide spray fluid from the tank to the spray nozzles.

7-2. Removal

Remove the synchromatic windmill assembly from the pump and brake assembly by removing the three attachment bolts (20, fig. 4-2).

7-3. Disassembly

Disassemble the synchromatic windmill assembly using figure 7-1 and the following steps as guides:

- a. Lift cap hub assembly (1) from base hub (3).
- b. Remove blades (2) from base hub or cap.

Note installation details for use during reassembly.

c. Remove actuator (4) from adjusting screw (8), noting its position for use during reassembly.

Note:

For normal maintenance do not remove roll pin and nut from adjusting screw.

d. Using a drift punch and a hammer, drive roll pin (5) from adjusting nut (6) and adjusting screw (8).

e. Carefully note details of adjusting nut and screw in cap hub for use during reassembly. Adjusting screw must be free to turn in hub, but must have no play or looseness. You may find it helpful to apply light lubricating oil or penetrating oil to the adjusting screw to free it in the hub. Before removing adjusting nut, determine how far you must turn the nut to tighten it. Record this information for later use. Then remove the adjusting nut (6), washers (7), and adjusting screw.

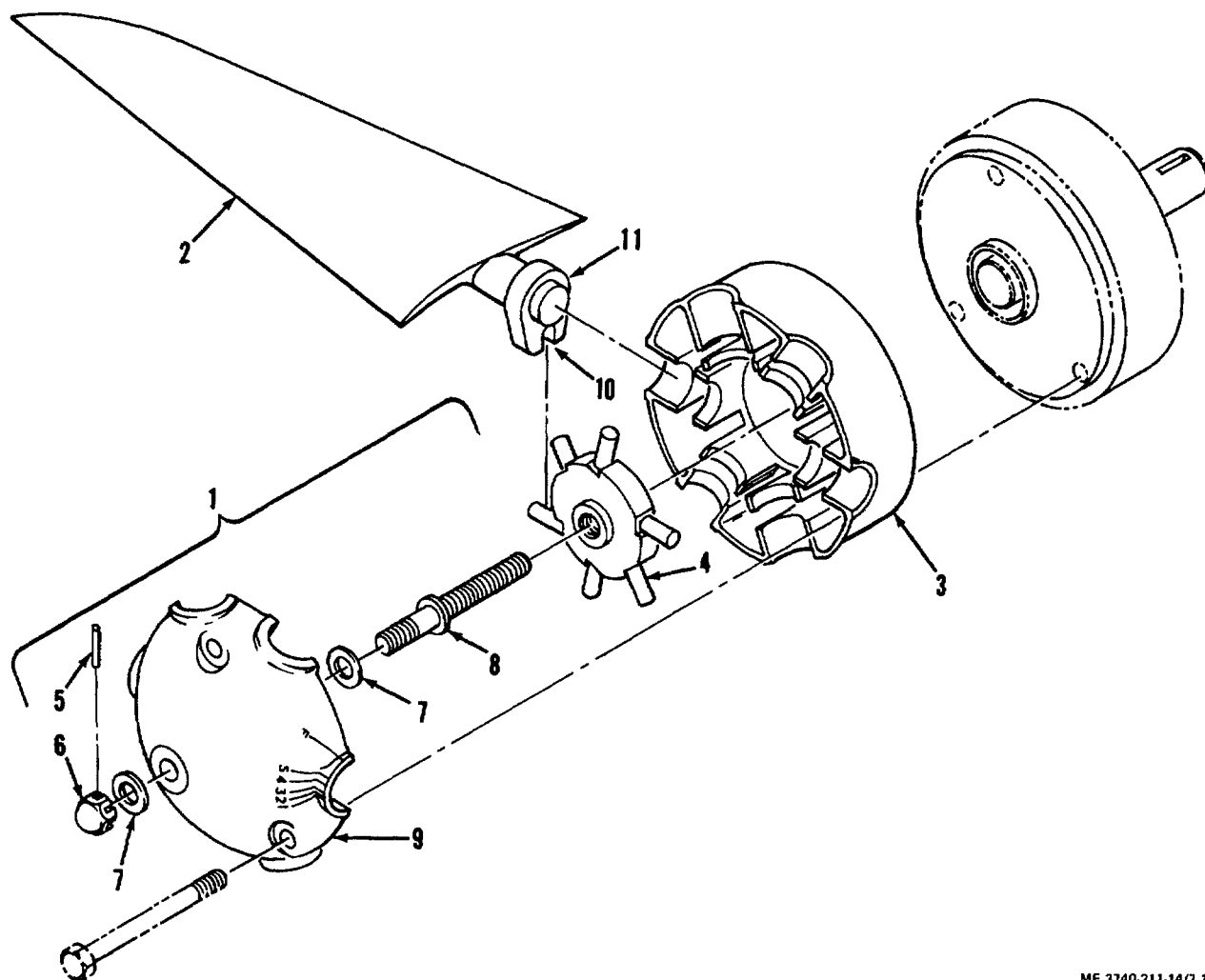

ME 3740-211-14/7-1

- | | | | |
|----|------------------|-----|------------------------------|
| 1. | Cap hub assembly | 7. | Washer |
| 2. | Blade | 8. | Adjusting screw |
| 3. | Base hub | 9. | Cap hub |
| 4. | Actuator | 10. | Retaining Shoulder slots |
| 5. | Roll pin | 11. | Blade hub retaining shoulder |
| 6. | Adjusting nut | | |

Figure 7-1. Synchromatic windmill assembly-- exploded view.

7-4. Cleaning, Inspection, and Repair

Clean all parts thoroughly to remove buildup of spray residue and dirt. Inspect and repair the synchromatic windmill assembly as described in paragraph 4-23, step e, with the following additional steps:

a. Check condition of threads on adjusting screw (8), adjusting nut (6), and actuator (4).

b. Check base and cap hubs (3 and 9) carefully for cracks, distortion, and for condition of blade hub bearing surfaces. Smooth out any rough areas which might affect blade adjustment.

Note:

Base and cup hubs are shipped as a matched set. If either needs to be replaced, replace both with a matched set.

c. Place blades (2) in boiling water for 30 minutes to restore flexibility.

7-5. Assembly

Assemble the synchromatic windmill assembly using figure 7-1 and the following steps as guides:

a. Assemble cap hub assembly (1) as follows:

(1) Lightly lubricate threads of adjusting screw (8) with instrument grease per Military Specification MI-G-23827.

(2) Place washer (7) over short end of adjusting screw.

(3) Place short end of adjusting screw through cap hub (9) and install second washer (7) over adjusting screw.

CAUTION

Position of adjusting nut on adjusting screw is critical. Adjusting screw must be free to turn in cap hub, but must not have excessive play or looseness.

(4) Attach adjusting nut (6) to adjusting screw (8), using one of the following steps, as applicable:

(a) If reusing both the adjusting nut and adjusting screw, turn adjusting screw down until it is just tight. Then back off by the amount noted during

disassembly (para 7-3, step e, preceding). Check to see that at this position, adjusting screw is free to turn with no play or looseness in the cap hub (9). If holes in adjusting nut and adjusting screw line up, insert a new roll pin (5). If holes do not align, drill new hole 0.062 in. diameter in a location that will miss existing hole.

(b) If a new adjusting nut only is required, turn the nut down on the adjusting screw, and then back off slightly, as noted in step (a), preceding. Check to see that adjusting screw is free to turn with no play or looseness. If hole in nut does not line up with hole in adjusting screw, drill a new hole through the adjusting screw. Use the hole in the adjusting nut as a guide, and drill hole of same size as in nut (0.062 inch diameter). Secure nut with new roll pin (5).

(c) If a new adjusting screw is required, find position of adjusting nut on adjusting screw as described in step (b), preceding. After determining correct position, drill hole through adjusting screw in line with hole in nut. Secure nut with new roll pin (5).

b. Complete assembly of synchromatic windmill assembly as instructed in paragraph 4-23, step f.

CAUTION

Do not try to turn blade angle when resistance to adjustment is noted. Internal damage to mechanism will result if parts are binding.

c. Check blade adjustment mechanism for operation. Turn adjusting nut (6) to adjust blade angle to maximum positions. Blade must be adjustable from position "I" to position "F" as noted on figure 4-8 without evidence of sticking or binding. If adjustment cannot be made freely, do not try to force the blade adjustment. Remove the cap hub assembly (1, fig. 7-1) and turn the actuator in the desired direction. Replace cap assembly and again test adjustment. Repeat this procedure until full adjustment of the blade angle can be made.

7-6. Installation

Attach the synchromatic windmill fan assembly to the pump brake drum as described in paragraph 4-23, step g.

Section II. BRAKE ASSEMBLY

7-7. General

The brake assembly (fig. 7-2) is attached directly to the spray fluid pump assembly (8). The brake assembly consists of a pair of brake shoes (4) contained inside a brake drum (2). Actuation of the brake arm by the brake lever (16, fig. 410) causes the brake shoes to expand against the brake drum. This action stops the synchromatic windmill assembly from turning, thereby stopping the pump. When the brake lever is released,

the brake shoes are returned to their normal position by the brake springs (5, fig. 7-2). This action allows the synchromatic windmill assembly and pump to operate.

7-8. Removal

a. Remove the synchromatic windmill assembly from brake drum by removing three attachment bolts (20, fig. 42).

b. Remove the brake assembly from the pump assembly using figure 7-2 and the following steps as guides:

Note:

Brake assembly may be removed from pump with pump installed on tank installation. For instructions on removal

of pump from tank installation, refer to paragraph 5-8, step a.

(1) Using a pair of snap ring pliers, remove snap ring (1) from end of pump shaft.

CAUTION

Do not beat on end of shaft.

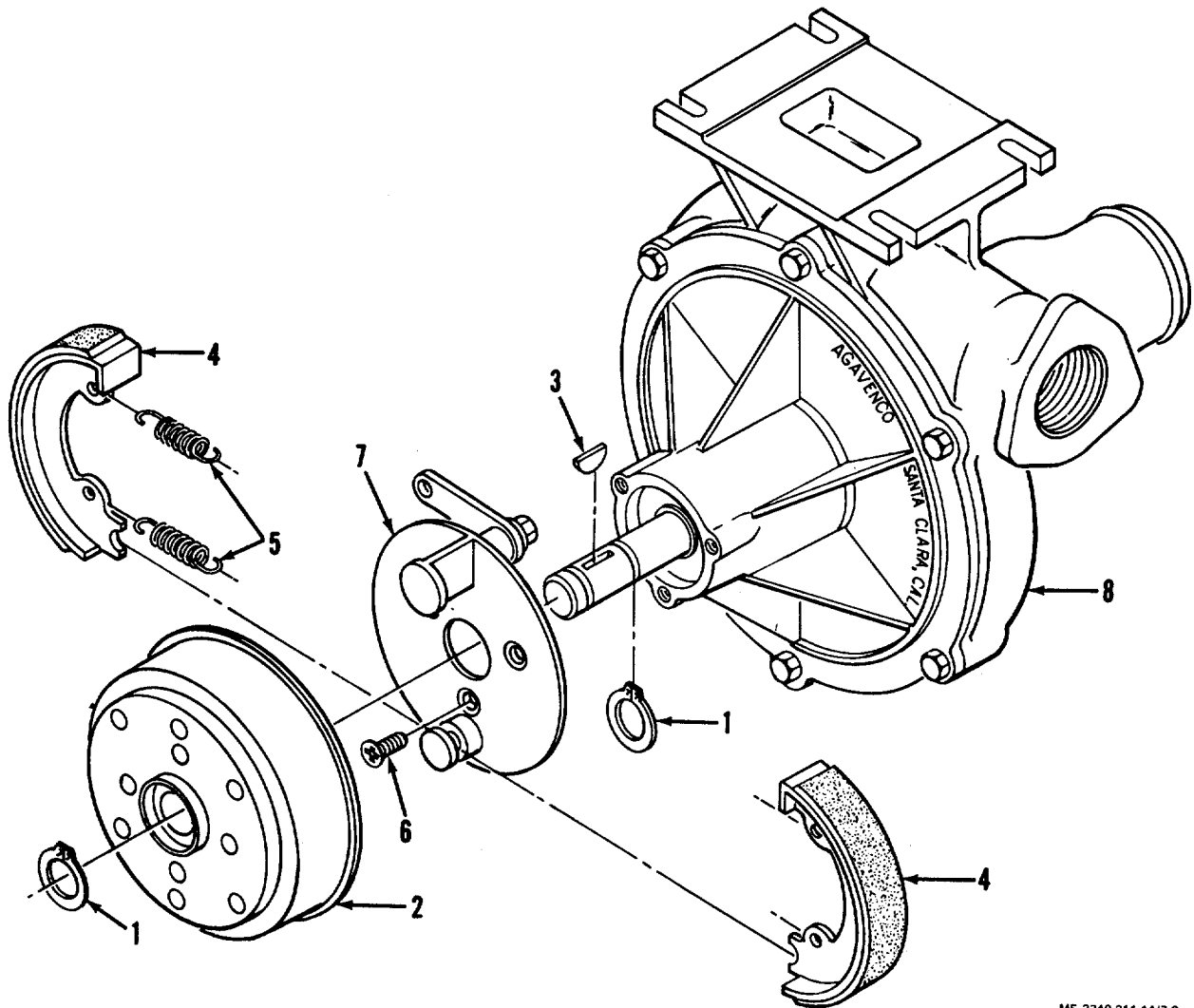

ME 3740-211-14/7-2

- | | |
|-----------------|--|
| 1. Snap ring | 6. Socket screw, flat head
1/4-20 x 1/2 |
| 2. Brake drum | 7. Brake back plate assembly |
| 3. Woodruff key | 8. Pump assembly (fig. 7-3) |
| 4. Brake shoe | |
| 5. Brake spring | |

Figure 7-2. Brake assembly - exploded view.

(2) With brake in off position, remove brake drum (2). Attach a gear puller to any two of the four 5/16-24 thread mounting holes in the brake drum. Using a wrench, tighten gear puller bolt against the end of pump shaft until drum slips off pump shaft.

(3) Remove woodruff key (3) from recess in shaft. (Not required if brake only is to be removed.)

(4) Remove brake springs (5) and carefully remove brake shoes (4) from brake back plate assembly (7).

(5) Using a pair of snap ring pliers, remove second snap ring (1) from pump shaft. (Not required if brake only is to be removed.)

(6) Using an allen wrench, remove three screws (6). Discard screws.

Note:

Observe position of back plate to pump for use during reassembly. Suggest marking location of brake actuation on pump body with grease pencil.

(7) Remove brake back plate assembly (7) from pump assembly (8).

7-9. Cleaning, Inspection, and Repair

WARNING

Avoid breathing dust found within brake assembly. Material worn off brake lining may be injurious to lungs.

a. Clean brake drum, shoes, and back plate assembly carefully to remove dust. Do not clean brake linings with oil-base cleaning fluids.

b. Inspect condition of all components, and replace any part not found to be usable. Make the following specific checks:

(1) Check interior of brake drum for scratches, grooves, or distortion.

(2) Check brake shoes for condition of lining. Thickness of lining should be 1/16 inch minimum.

(3) Check springs for condition and tension.

(4) Check brake back plate for flatness and for condition of actuation arm. Arm should rotate freely in back plate.

c. Repair or replace components as required, noting the following:

(1) Remove light scratches from interior of brake drum by smoothing out with crocus cloth per Federal Specification P-C-451. Polish in direction of drum rotation only, never across drum.

(2) Replace brake shoes if lining is

considered too thin to last until next regular overhaul.

(3) Replace springs if kinked, bent, or damaged.

(4) Replace brake back plate assembly if bent or if actuation arm is bent or will not operate smoothly.

7-10. Assembly

Assemble brake assembly to pump assembly using figure 7-2 and the following steps as guides:

a. Using three new screws (6) and an allen wrench, attach brake back plate assembly (7) to pump assembly (8). Position back plate assembly such that actuation arm is in line with the word AGAVENCO on pump body (between pump foot and outlet port). Secure screws handtight.

b. Place brake shoes (4) together with the flat ends facing each other. Holding brake shoes together, install brake shoes to stud on back plate assembly. Fit flat ends of brake shoes on each side of actuation arm shaft of brake plate assembly. Install brake springs (5) to secure brake shoes in position on back plate assembly.

c. Using snap ring pliers, install snap ring (1) in inner groove of pump shaft.

d. Insert woodruff key (3) into recess in pump shaft.

e. Install brake drum (2) over pump shaft, woodruff key, and brake shoes.

f. Test fit of brake drum by spinning brake drum with brake shoes in relaxed position. If any brake drag occurs, operate brake by hand and rotate brake drum by hand. Relieve pressure on brake lever and continue to rotate brake drum. If brake still drags remove brake drum and lightly file brake shoe lining to remove any high spots. Replace brake drum and again check for rotational freedom. Repeat these steps as required until brake drum spins freely with no evidence of drag.

g. Secure brake assembly with snap ring (1) in outer groove of pump shaft.

Section III. PUMP ASSEMBLY

7-11. General

The pump portion of the pump and brake assembly (19, fig. 4-9) is a centrifugal type, driven by the synchromatic windmill assembly. Pump speed depends upon the windmill fan blade angle and helicopter forward flight speed. The pump is stopped and started by the brake lever (16, fig. 4-10) on the manual control panel.

7-12. Removal

Remove pump and brake assembly from tank installation

as described in paragraph 5-8, step a. Remove brake assembly as described in paragraph 7-8, step b.

7-13. Disassembly

Disassemble pump assembly using figure 7-3 and the following steps as guides:

a. Remove screws (1) and washers (2) securing inlet (3) to case (21). Remove inlet and gasket (4). (Not required unless gasket is leaking.)

b. Remove screws (5) and washers (6) securing body (19) to case (21). Remove body and attached parts (8 through 19) and gasket (7) from case.

c. Remove bolt (8) and lock washer (9) from impeller shaft (18). Discard bolt. Insert a 3/8-16 coarse-thread bolt into the center hole of the impeller (12). Threaded end of bolt must be at least 1.0 inch long.

Tighten this bolt against the shaft end (18) to remove impeller. Remove bolt from impeller.

d. Using two flat blade screwdrivers, pry the stationary seal (10) from the impeller. Discard seal. Pressure should be applied evenly to both sides of seal to prevent damage to impeller.

e. Remove pin (11) from slot in impeller hub.

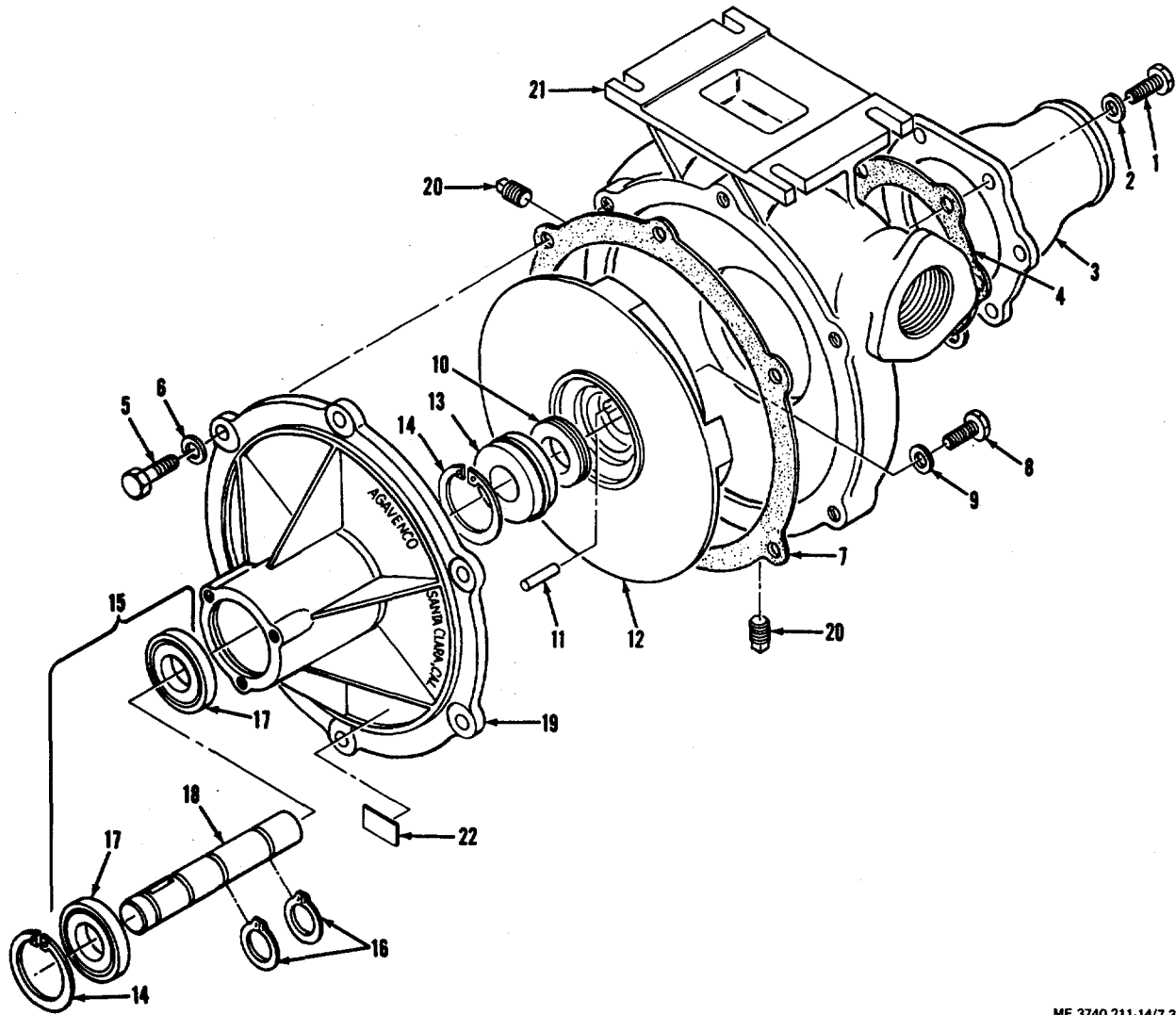

ME 3740-211-14/7-3

- | | |
|----------------------|--------------------------------|
| 1. Screw | 13. Main seal |
| 2. Washer, AN960-416 | 14. Snap ring |
| 3. Inlet | 15. Shaft and bearing assembly |
| 4. Gasket | 16. Snap ring |
| 5. Screw | 17. Bearing |
| 6. Washer, AN960-516 | 18. Shaft |
| 7. Gasket | 19. Body |
| 8. Bolt | 20. Plug Y%-27 |
| 9. Washer, Lock | 21. Case |
| 10. Stationary seal | 22. Identification plate |
| 11. Pin | |
| 12. Impeller | |

Figure 7-3. Pump assembly - exploded view.

f. Using two flat blade screwdrivers, pry main seal (13) from pump body. Use the two recesses in pump body at edges of seal for this purpose. Discard seal. Pressure should be applied evenly to both sides of seal to prevent damage to pump body. Blocking under screwdriver will increase leverage.

Note:

At this point in disassembly, check condition of bearings to determine if further disassembly is necessary. If further disassembly is necessary, continue with succeeding steps. If not, go to paragraph 7-15, step g, to reassemble pump assembly.

g. Using snap ring pliers, remove snap rings (14) from both ends of shaft (18) within body hub.

CAUTION

Do not hammer shaft and bearings from body as damage to shaft and body will result.

h. Using an arbor press and a large socket or a piece of pipe, press shaft and bearing assembly (15) from body.

i. Remove snap rings (16) from shaft.

j. Using arbor press and large socket or piece of pipe, press bearings (17) off shaft. Discard bearings.

k. Remove plugs (20) from case, to complete disassembly of pump assembly.

l. If necessary for replacement, remove identification plate (22) from body (19).

7-14. Cleaning, Inspection, and Repair

WARNING

Use cleaning solvent in well-ventilated area. Avoid breathing of fumes and excessive contact with skin. Keep away from open flame. Wash hands before eating or smoking.

CAUTION

Do not use wire brush or other materials which might scratch metal surface on sealing surface of impeller or on bearing surface within body hub.

a. Clean all portions of the pump assembly thoroughly to remove buildup of spray fluid residue, dirt, lubricants, and sealants. Use cleaning solvent per Federal Specification P-D-680 to remove oily substances. A stiff wire brush may be used on nonsealing areas such as the impeller face and body casting to remove caked material.

b. Inspect condition of all components and replace any parts not found to be usable. Make the following specific checks:

(1) Check sealing surface within impeller hub (12, fig. 7-3). This surface must be clean and smooth for assembly.

(2) Check body (19) and case (21) carefully for cracks or damage.

(3) Check bearing surfaces within hub of body (19). This surface must be free of scratches, nicks, and burrs.

(4) Check all threaded parts for crossed or otherwise damaged threads.

(5) Check condition of all gaskets. Discard broken or cracked gaskets.

c. Repair or replace parts of pump assembly as required, noting the following:

(1) Replace bolt (8), seal assembly (10 and 13), and bearings (17) at overhaul, regardless of their apparent condition.

Note:

Seal assembly (10 and 13) on original unit contains viton rubber components. Replacement seals contain Teflon components. Therefore, on first overhaul of unit, the replacement seal may look different than the seal being replaced.

(2) Remove minor scratches from sealing surface of impeller (12) and from interior of body (19) hub. Use crocus cloth, Federal Specification P-C-451. Polish in direction of part rotation only, never cross sealing or bearing areas. Reclean parts per step a, preceding, after repair.

7-15. Assembly

Assemble the pump assembly using figure 7-3 and the following steps as guides:

a. Using snap ring pliers, insert snap ring (14) in groove within body (19) hub on side toward impeller.

CAUTION

Use care when installing bearings not to allow them to cock to one side. Scoring of bearing surface in hub and preloading of bearings may result.

b. Using an arbor press and a piece of pipe, press one new bearing (17) into body hub. Insert from brake side of hub and press carefully down against snap ring. Use care not to press against bearing surfaces.

c. Using snap ring pliers, install two snap rings (16) into grooves on shaft (18) away from woodruff key recess.

d. Install shaft (18) in body hub and press into bearing using an arbor press. Press in carefully, until snap ring on shaft contacts bearing.

e. Using arbor press and a large socket or piece of pipe, press remaining bearing (17) onto shaft. Press carefully down against snap ring on shaft. Use care not to press against bearing surfaces.

f. Using snap ring pliers, install second snap ring (14) into groove in body hub.

g. Using arbor press and a large socket or piece of pipe, carefully press new main seal (13) into

body (19). Press enclosed end of seal into body hub until flange on seal is seated in hub. Use care not to press against sealing surface.

Note:

Upon original seal installation at factory, seal assembly (10 and 13) was lubricated with John Crane plastic lead seal No. 2. However, replacement seals are pre-lubed (as noted by blue color) and, therefore, do not require lubrication upon installation.

h. Install new stationary seal (10) in impeller (12). Be sure seating surface in impeller is smooth and clean. Apply a light coating of oil per Federal Specification VV-L-820 to seating surface of impeller and to rubber packing on seal. Install seal so that polished surface will make contact with black surface of main seal (13). Do not allow oil to get on sealing surface of seals.

i. Install pin (11) into slot in impeller (12) hub.

j. Apply sealant (Tite-seal T-3504), or equivalent to screw threaded end of pump shaft (18).

k. Insert impeller (12) over end of pump shaft. Be careful not to allow sealant to come in contact with mating surfaces of seal assembly (10 and 13).

l. Secure impeller (12) to pump shaft (18) with lock washer (9) and new bolt (8). Check impeller for freedom of rotation.

m. Attach body (19) and gasket (7) to case (21) using washers (6) and screws (5). Place body such that word AGAVENCO goes between pump foot and outlet port.

n. Install gasket (4) and inlet (3) to case (21) using washers (2) and screws (1).

o. Install two plugs (20) into threaded holes in case (21).

p. If identification plate (22) was removed, transfer all information from old plate to new plate. Remove adhesive backing from new plate and install in approximate position shown in figure 7-3.

7-16. Installation

Attach the pump and brake assembly to the pump support assembly as described in paragraph 5-8, step *b*.

CHAPTER 8
REPAIR OF VALVES, COUPLING, AND TANK

Section I. FLOW CONTROL AND BYPASS VALVES

8-1. General

Two valves (fig. 8-1), which are identical in design and function except for end fittings, are used in the insecticide sprayer. They are manually operated, ball type, flow control valves containing a back pressure bleed passage. The valves are used to control flow of insecticide fluids within the sprayer system. Back pressure is controlled by an adjustable screw.

8-2. Removal

- a. Remove the control valve assembly (47, fig. 4-9) as instructed in paragraph 5-9, step a.
- b. Remove the bypass valve assembly (52, fig. 4-

9) as instructed in paragraph 5-12, step a. If tank assembly (125) is removed from tank support assembly (133), remove bypass valve as instructed in paragraph 8-11, step c.

8-3. Disassembly

Disassemble the control valve or bypass valve using figure 81 and the following steps as guides:

Note:

Discard removed parts that are to be replaced from overhaul kit.

- | | | | |
|------------------------|----------------|--------------|------------------------|
| 1. Nut | 12. *Seat | 23. *Gasket | 34. Shaft end cap |
| 2. Washer | 13. Bolt | 24. *O-ring | 35. *Gasket |
| 3. Bolt | 14. Washer | 25. *Seat | 36. *Quad ring |
| 4. Lever | 15. Fitting | 26. Bolt | 37. *Thrust washer |
| 5. Bolt | 16. Fitting | 27. Washer | 38. Ball |
| 6. Washer | 17. *Gasket | 28. *Bearing | 39. *O-ring |
| 7. Fitting | 18. *O-ring | 29. Cap | 40. Flow control screw |
| 8. Fitting (45° elbow) | 19. *Seat | 30. *Gasket | 41. Body |
| 9. Flange | 20. Bolt | 31. Bolt | |
| 10. *Gasket | 21. Washer | 32. Washer | |
| 11. *O-ring | 22. Cap (7517) | 33. *Bearing | |

*Parts contained in overhaul kit PN K7520-1

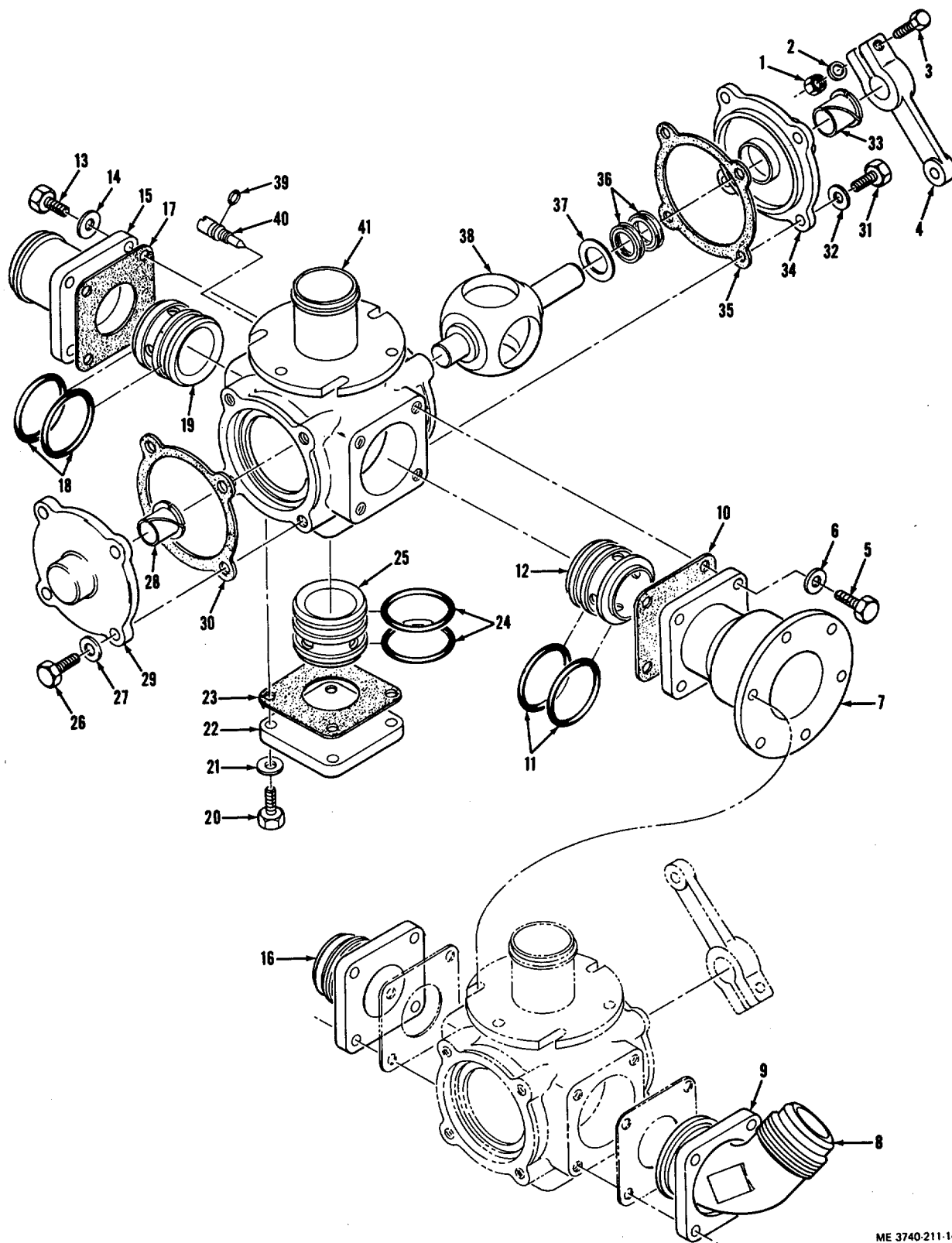

ME 3740-211-14/8-1

Figure 8-1. Valve assembly - exploded view.

a. Remove nut (1), washer (2), and bolt (3) holding lever (4) to shaft of ball (38). Remove lever, noting its position relative to ball position in valve for aid during assembly.

b. Remove four bolts (5) and washers (6). Remove fitting (7) from bypass valve, or fitting and flange (8 and 9) from control valve.

c. Remove gasket (10) and seat (12) from body (41); remove O-rings (11) from seat.

d. Remove four bolts (13) and washers (14). Remove fitting (15) from bypass valve, or fitting (16) from control valve.

e. Remove gasket (17) and seat (19) from body (41); remove O-rings (18) from seat.

f. Remove four bolts (20) and washers (21), and remove cap (22), gasket (23), and seat (25) from body (41). Remove O-rings (24) from seat.

g. Remove four bolts (26) and washers (27), and remove can (29) and gasket (30) from body (41); remove bearing (28) from cap.

h. Remove four bolts (31) and washers (32), and remove shaft end cap (34) and gasket (35) from body (41). Remove bearing (33) and quad rings (36) from shaft end cap.

i. Remove ball (38) from body (41); remove thrust washer (37) from shaft of ball.

l. Remove flow control screw (40) from body (41); remove O-rings (39) from flow control screw.

k. Discard all kitted Darts (noted on key to fig. 8-1). These parts shall be replaced by new parts from the overhaul kit at assembly.

8-4. Cleaning, Inspection, and Repair

Thoroughly clean and inspect all reusable parts of the valve as follows:

a. Inspect all metal parts for nicks, scratches, cracks, or other damage. Polish out minor defects using crocus cloth, Federal Specification P-C-458 for steel parts and aluminum oxide abrasive cloth, Federal Specification P-C-451 for aluminum parts.

b. Inspect all threaded parts for crossed or otherwise damaged threads.

c. Inspect surfaces of ball (38) for condition.

8-5. Assembly

Reassemble the valve in accordance with the following steps, using new parts from overhaul kit for those parts noted in the key to figure 8-1. Assembly of the bypass valve (52, fig. 4-9) and control valve assembly (47) is identical except where noted.

a. Place new O-ring (39) on flow control screw (40). Grease O-ring and insert flow control screw into body (41). For bypass valve tighten flow control screw down tight against seat. For control valve, tighten flow control screw down against seat, and then back off about 3/4 turn.

b. Assemble new bearing (28) in cap (29). Attach gasket (30) and cap (29) to body (41). Secure with four washers (27) and bolts (26). Refer to figure 8-1 for proper location of parts.

c. Install ball (38) with short shaft into bearing (28) in cap (29) installed in body (41) in step b, preceding.

d. Place thrust washer (37) over long shaft of ball (38).

e. Install quad rings (36) and bearing (33) into shaft end cap (34).

f. Grease quad rings and long end of shaft on ball (38).

g. Attach gasket (35) and shaft end cap (34) to body (41) over long shaft of ball (38). Secure with four washers (32) and bolts (31). Check ball for freedom of movement.

h. Place one each new O-ring (24, 18, and 11) in groove closest to concave sealing surface of three new seats (25, 19, and 12). Grease O-rings and slide seats into the three ports of body (41).

i. Place one each new O-ring (24, 18, and 11) in exposed groove of seats (25, 19, and 12).

j. To reassemble bypass valve, place new gaskets (23, 17, and 10) under cap (22) and fittings (15 and 7). Refer to figure 8-1 for proper locations of parts. Secure parts to body (41) using four washers (21, 14, and 6) and bolts (20, 13, and 5) at each location.

k. To reassemble control valve, place new gaskets (23, 17, and 10) under cap (22), fittings (16), and flange (9). Slip flange (9) over fitting (8). Refer to figure 8-1 for proper locations of these parts. Secure parts to body (41) using four washers (21, 14, and 6) and bolts (20, 13, and 5) at each location.

Note:

Bolts (5) securing flange (9) and elbow fitting (8) may be left slightly loose. Fitting is rotated on final assembly to insecticide sprayer and is secured when proper location is determined.

l. Place lever (4) over exposed end of long shaft of ball (38). Secure in same position noted on disassembly with bolt (3), washer (2), and nut (1).

m. Check valve for freedom of movement.

Section II. VALVED QUICK-DISCONNECT COUPLING

8-6. General

A valved nipple (36, fig. 4-9) is attached to the liquid loading tube (41). The valved nipple (fig. 8-2) contains a poppet which is spring-loaded closed against a seat within the body. The valved nipple forms the male half of a quick-disconnect coupling. A valved coupler forms the female half of the quick-disconnect coupling and is part of the liquid loading system (ch. 11). When the coupling halves are mated, valves within each half of the coupling force each other open. The coupling is held together by

balls in the valved coupler half which engage in a groove on the valved nipple half. The balls are retained in place by a sleeve on the valved coupler half. Sliding the sleeve away releases the balls, allowing the coupling halves to disengage. When disconnected, springs within each coupling half return the respective poppets to the closed position. A dust cap and dust cover are attached to the valved nipple and valved coupler, respectively, by steel cables. The dust cap and cover are used to cover the open ends of the coupler to protect them from dirt, grease, and other contaminants.

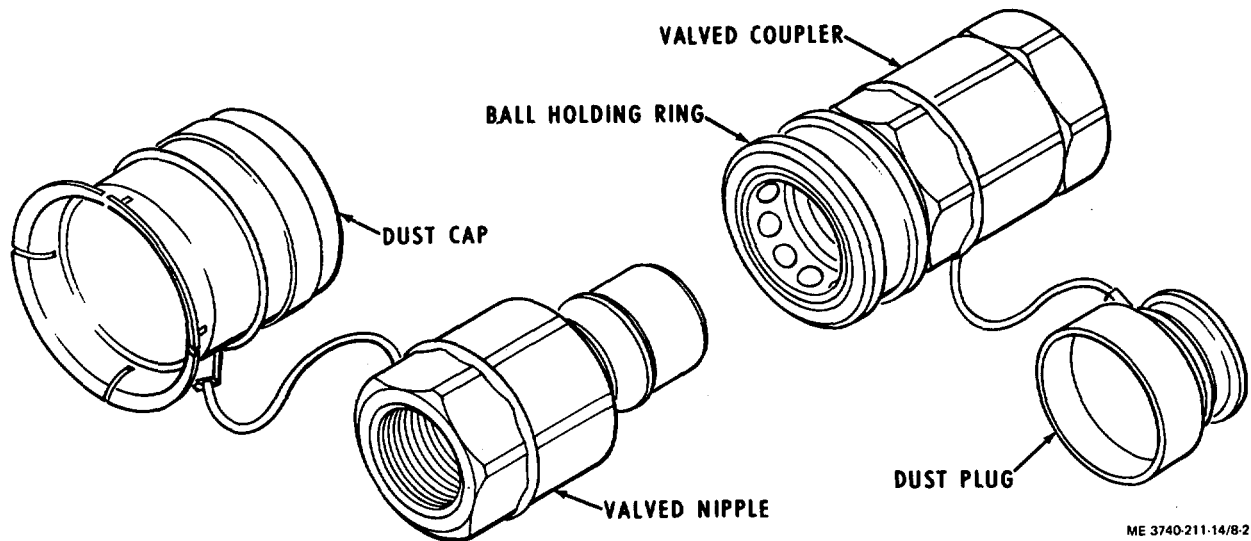

Figure 8-2. Valved quick-disconnect coupling.

8-7. Removal

Remove the valved nipple from ground loading tube of the insecticide sprayer as described in paragraph P16, step c.

8-8. Cleaning and Inspection

a. Clean all parts of the valved quick-disconnect coupling thoroughly to remove spray fluid residue, dirt, lubricants, and other contaminants.

b. Inspect condition of all parts. Make the

following specific checks:

(1) Check threaded parts for crossed or otherwise damaged threads.

(2) Check condition of teflon seals on valve assemblies for cuts or contamination with foreign particles.

(3) Check seating surfaces within nipple and coupler for nicks, scratches, or other damage.

c. Discard valved nipple or coupler if either is found not to be usable.

Section III. TANK ASSEMBLY

8-9. General

The tank assembly (125, fig. 4-9) consists of a cylindrical, molded fiberglass tank with attachment fittings for components connected to the tank. The tank has a 200-gallon capacity and is a molded fiberglass reinforced polyester resin structure. It contains two

internal baffles provided for strength and to reduce sloshing of fluid within the tank during flight. The tank is translucent with fluid level markings on each end. A fluid level gage is mounted on the front side. Fluid level within the tank can be seen through the tank material. In addition, connectors for components attached to the tank are permanently attached.

8-10. Removal

Remove tank assembly from tank support assembly (133, fig. 4-9) as instructed in paragraph 5-16, step *a*.

8-11. Disassembly

Remove components attached to tank assembly using figure 4-9 and the following steps as guides:

- a.* Remove top fill cap and strainer components (115 through 119) as instructed in paragraph 4-17, step *c*.
- b.* Unscrew elbow (112) from tank connector, and adaptor (111) from elbow.
- c.* Remove bypass valve assembly (52) from tank connector by cutting and discarding lockwire (48) and removing six bolts (49) and washers (50). Remove bypass valve and gasket (51).
- d.* Remove sump (34) from tank as instructed in paragraph 5-15, step *a*.
- e.* Remove liquid level gage (110) from tank connector as instructed in paragraph 5-14, step *a*.

8-12. Cleaning, Inspection, and Repair

- a.* Clean tank thoroughly to remove buildup of spray fluid residue and other foreign matter. Clean all threaded parts and connectors.
- b.* Inspect tank for damage, cracks, and holes. Determine extent of damage and if tank can be repaired. If damage is too severe, replace tank. Inspect attachment fittings and connectors for security and condition of threads.
- c.* Repair minor cracks, holes, or other leaks by pushing epoxy resin through opening and permit it to cure for the required time. Follow directions on epoxy container carefully when preparing and using the material. Tank areas to be repaired must be prepared by thorough cleaning and roughening of the surface. Generally, this may be done by sandpapering. Sharp edges should be beveled to insure secure bonding. All surfaces to be bonded must be kept free of dirt, oil, grime and fingerprints.
- d.* Repair of larger damage requires use of a reinforced patch of glass or linen cloth on top of previously applied epoxy. Coverage must extend beyond

all fractured areas. Large holes should be backed up by a flat piece of wood, paperboard, or similar while applying material. Cover entire patch with epoxy and allow to cure. The size and nature of damage may indicate the need for additional layers of patching material.

8-13. Assembly

- a.* Assemble the tank assembly using figure 4-9 and the following steps as guides:
 - (1) Install liquid level gage (110) in tank as instructed in paragraph 5-14, step *b*.
 - (2) Install sump (34) to opening in bottom of tank as instructed in paragraph 5-15, step *b*.
 - (3) Install bypass valve in opening in bottom front of tank as follows:
 - (a)* Coat new gasket (51) and bolts (49) with Tite-seal gasket and joint sealing compound, part No. T3504 or equivalent.
 - (b)* Place gasket (51) on flange of bypass valve (52) with mounting holes aligned.
 - (c)* Place valve into position, with valve mounting flange mating with connector flange. Align mounting holes so that valve end ports are canted to approximately 5 o'clock/11 o'clock position as viewed from front of tank. Be sure flow direction arrow on valve points toward end of tank.
 - (d)* Attach valve to connector flange with six washers (50) and bolts (49). Secure bolts tight, and then lockwire per MS33540. Lockwire three bolts on each side together, with breaking point in line with flow control screw on valve (40, fig. 8-1).
 - (4) Wrap male threads of elbow (112) and pipe to hose adaptor (111) with teflon tape, Military Specification MILT-27730. Install elbow (112) into tank connector, and pipe to hose adapter (111) into elbow.
 - (5) Install top fill strainer assembly and cap (115 through 119) as instructed in paragraph 4-17, step *e*.

8-14. Installation

Install tank assembly into tank support assembly (133) as instructed in paragraph 5-16, step *b*.

CHAPTER 9 REPAIR OF TANK SUPPORT ASSEMBLY

Section I. TANK SUPPORT ASSEMBLY

9-1. General

The tank support assembly (133, fig. 4-9) consists primarily of aluminum alloy channel rail, connected together by aluminum alloy sheet. It is assembled by riveting and welding. The tank support provides the base to which the remainder of the insecticide sprayer is mounted. It also provides the means for attaching the sprayer to the helicopter.

9-2. Disassembly

a. Remove parts from the tank support assembly per instructions in chapter 5.

b. Remove pump support assembly (107, fig 4-9) from tank support assembly (133) using figure 4-9 and the following steps as guides:

(1) Remove pump struts (91 and 95) as follows:

(a) Remove nuts (82), washers (83), and bolts (84) securing pump struts to eyebolts (99) in flange of pump support assembly (107).

(b) Remove nut (85), washer (86), and bolt (87) securing long pump strut (91) to eyebolt (90). Remove long pump strut.

(c) Remove nut (88), washer (89), and eyebolt (90) from rear upper channel rail of tank support assembly (133).

(d) Remove nut (92), washer (93), and bolt (94) securing short pump strut (95) to complete removal of short pump strut.

(e) Remove nuts (96), washers (97), bushings (98), and eyebolts (99) from flange of pump support assembly (107).

(2) Complete removal of pump support assembly (107) from tank support assembly (133) by removing nuts (100), washers (101) and bolts (102).

c. Remove bracket (106) from pump support assembly (107) by removing nuts (103), washers (104), and screws (105).

d. Remove eight handles (109) from bottom tank support rails by removing screws (108).

e. Remove four stray end tiedown fittings (128) from upper tank support rails by removing nuts (126) and washers (127).

f. Remove four tank clamps (132) from tank support cradle channels by removing nuts (129), washers (130), and screws (131)).

g. If tiedown lugs (28, fig. 4-2) are attached to tank support assembly, remove tiedown lugs using figure 4-2 and the following steps, as required:

(1) Remove cotter pin (25), if in place.

(2) Remove lock nut (26) and washers (27).

(3) Remove tiedown lug (28).

9-3. Cleaning, Inspection, and Repair

a. *Cleaning.* Clean all portions of the tank support assembly to remove spray residue, dirt, rust, or other foreign matter.

b. *Inspection.* Inspect all portions of the tank support assembly for damage that might impair operation of the insecticide sprayer. Check condition of all threaded parts, and all attachment or mounting holes. Check security of rivets and weldments. Mark any areas found or suspected of being faulty or in need of repair. Inspect security of attachment and condition of felt cushions (124, fig. 4-9) on inside of cradle channels.

c. *Repair.* Repair tank support assembly only as required, noting the following:

(1) Repair channel rails and sheet metal portions by straightening, patching, or replacing any parts found to be faulty. Remove parts by drilling out rivets or cutting weldments as required. Cut new pieces to size, using removed parts as a pattern. Drill new rivet holes in exact locations, and deburr holes. Locate parts into position, with all joints tight against one and other. Rivet parts in place per Military Standard MILSTD-403. Check to see that all rivets are securely installed.

(2) Perform any welding required per Military Specification MIL-W-45205, Class B.

(3) Replace felt cushion (124, fig. 4-9) on cradle channel if missing, torn, or badly worn. Center cushion on channel and attach to channel with glue. Allow glue to set before installing tank.

(4) On completion of repair operations, reclean tank support assembly thoroughly to remove any dirt or oil. Treat metal per Military Specification MIL-C-5541 and paint per Military Specification MILC-22751C, color gray, No. 26231. Corrosion resistant steel parts will require pretreatment per Military Specification MIL-C-8514.

(5) Paint area around nine mounting holes in tank support base used for UH-1D installation (fig. 4-4). Use red color No. 31136 per Federal Standard FED-STD-595.

9-4. Assembly

a. Attach bracket (106, fig. 49) to pump support assembly (107) using screws (105), washers (104), and nuts (103).

b. Attach pump support assembly to tank support assembly using figure 4-9 and the following steps as guides:

(1) Install short pump strut (95), to upper channel rail on front of tank support assembly (133). Attach with bolt (94), washer (93), and nut (92). Do not secure nut at this time.

(2) Install eyebolt (90) through hole in upper channel on rear of tank support assembly. Insert eyebolt from front side of channel. Place washer (89) and nut (88) on eyebolt. Do not secure nut at this time.

(3) Attach long pump strut (91), to eyebolt (90). Attach with bolt (87), washer (86), and nut (85). Do not secure nut at this time.

(4) Attach eyebolts (99) to remaining ends of pump struts (91 and 95). Attach with bolts (84), washers (83), and nuts (82). Do not secure nuts at this time.

(5) Attach pump support assembly (107) to lower front rail of tank support assembly (133). Attach with bolts (102), placed from inside channel, washers (101), and nuts (100). Do not secure nuts at this time.

(6) Insert eyebolts (99) on ends of pump support struts (91 and 95) through top holes of flange of

pump support assembly (107). Install bushings (98), washers (97), and nuts (96) on pump side of flange. Do not secure nuts at this time.

(7) Check position and alignment of all parts, then secure all nuts (100, 96, 92, 88, 85, and 82).

c. Attach eight handles (109) to tank support bottom rails using screws (108) to secure handles in place.

d. Attach two strap end tiedown fittings (128) to each upper rail on front and rear of tank support assembly (133). On front rail, fittings go on top of rail; on rear rail, fittings go on bottom of rail. Secure in place with washers (127) and nuts (126).

e. Attach four tank clamps (132) to ends of tank support cradle channels. Strap ends go inside channel, with clamp facing outward. Secure with screws (131), washers (130), and nuts (129). Insert screws from inside of channel rings.

f. If desired to install tiedown lugs (28, fig. 4-2) to tank support base, place one washer (27) over lug, and install tiedown lug body from underneath frame. Place second washer (27) over lug, and secure lug to tank support frame with nut (26). Secure parts of tiedown lug in place with cotter pin (25).

Section II. TANK STRAPS, STRUT, AND TIEDOWN LUGS

9-5. General

Two tank strap assemblies (123, fig. 4-9) are used to secure the tank assembly (125) to the tank clamps (132). Pump struts (91 and 95) are used to support the pump support assembly (107). Tiedown lugs (28, fig. 4-2) are used to secure the insecticide sprayer to the helicopter cargo deck (fig. 4-3 or 4-4) or to the skid frame (fig. 4-1).

9-6. Removal

a. Remove tank strap assemblies (123, fig. 4-9) as instructed in paragraph 5-16, step *a* (7).

b. Remove tank clamps (132) as instructed in paragraph 9-2, step *f*.

c. Remove pump struts (91 and 95) as instructed in paragraph 9-2, step *b* (1).

d. Remove tiedown lugs (28, fig. 4-2) as instructed in paragraph 9-2, step *g*.

9-7. Cleaning, Inspection, and Repair

a. Clean all parts thoroughly to remove buildup of spray residue, dirt, and grease.

b. Inspect parts for serviceability. Check all

threaded parts, attachment holes, and rivets *for* general condition.

c. Repair components as found necessary by removing dents from struts (91 and 95, fig. 4-9), and replacing rivets in strap assemblies (123), tank clamps (132), and struts. Replace rivets by drilling out old rivets and replacing with exact duplicate or with next larger size if required. Install rivets per Military Standard MIL-STD-403.

9-8. Installation

a. Attach tank clamps (132, fig. 4-9) to tank support assembly (133) as instructed in paragraph 9-4, step *e*.

b. Attach tank strap assemblies (123) to secure tank assembly (125) to tank support assembly (133) as instructed in paragraph 5-16, step *b* (4).

c. Attach pump struts (91 and 95) to tank support assembly (133) as instructed in paragraph 9-4, step *b*.

d. Attach tiedown lugs (28, fig. 4-2) to tank support base if required, as instructed in paragraph 9-4, step *f*.

CHAPTER 10 REPAIR OF MANUAL CONTROL PANEL

Section I. GENERAL

10-1. Introduction

The manual control panel (fig. 4-10) primarily consists of a support (25) and a control bracket (27). The support is hinged at the bottom and contains a folding brace. The

control bracket is attached to the support and may be adjusted to two positions as required for installation into the UH-1B or UH-1D helicopters (para 4-3).

Section II. REMOVAL AND DISASSEMBLY

10-2. Removal

Remove the manual control panel from tank installation as instructed in paragraph 5-17, step *a*.

control panel as instructed in paragraph 4-24, step *c*.
b. Remove control bracket (27, fig. 4-10) from support (25) by removing nuts (23) and screws (24).

10-3. Disassembly

- a*. Disassemble components from the manual

Section III. CLEANING, INSPECTION, REPAIR, AND ASSEMBLY

10-4. Cleaning

Clean all portions of the manual control panel to remove spray residue, dirt, rust, or other foreign matter.

d. Drill new holes to exactly match holes in mating parts.

e. Assemble parts using rivets, cherry lock bolts, or by welding, to match original assembly.

f. Install rivets in accordance with Military Standard MIL-STD-403.

g. Perform welding in accordance with Military Specification MIL-W-6858.

h. Reclean assembly after repair to remove burrs, chipped paint, dirt, and oil.

i. Treat bare metal surfaces in accordance with Military Specification MIL-T-704, and paint in accordance with Military Specification MILP-22806, using gray paint no. 26231.

10-5. Inspection

Inspect all portions of the manual control panel for damage that might impair operation of the insecticide sprayer. Check for the following specific items:

- a*. Bent, broken, or loose components.
- b*. All rivets, cherry lock bolts, and weldments for security.
- c*. Operation and security of hinge and folding brace.
- d*. Fit of control bracket (27, fig. 4-10) in support (25).

10-7. Assembly

a. Place control bracket (27, fig. 1-10) into position on support (25). Secure with four screws (24), and nuts (23). Nuts go on outside of frame.

b. Install levers (16 and 17), valve rod (15), and pressure gage (21) to manual control panel as instructed in 4-24, step *e*.

10-6. Repair

Repair the control support components as found necessary, using the following as a guide:

- a*. Remove and replace damaged sheet metal components as required.
- b*. Drill out rivets or cut away cherry lock bolts with a hammer and chisel.
- c*. Fabricate replacement parts using removed components as patterns.

10-8. Installation

Install manual control panel to tank installation as instructed in 5-17, step *b*.

CHAPTER 11
MAINTENANCE OF LIQUID LOADING SYSTEM

Section I. GENERAL

11-1. Introduction

a. The liquid loading system is shown in figure 11-1. The system consists of an engine driven pump (1), a pump inlet strainer assembly (11), a shutoff ball valve (2), and three hoses (8). The liquid loading system is used to pump liquid insecticide fluid from storage drums into the aircraft-mounted insecticide sprayer. The liquid loading system is part of the sprayer system. One liquid

loading system is shipped with each insecticide sprayer. Attached to the pump inlet port is a 12-foot length of hose and a suction pipe. Attached to the pump outlet port is a ball type shutoff valve and two 12-foot lengths of hose. Quick-disconnect couplings are used to connect the hoses to other components of the liquid loading system and to the insecticide sprayer for loading insecticide spray fluid.

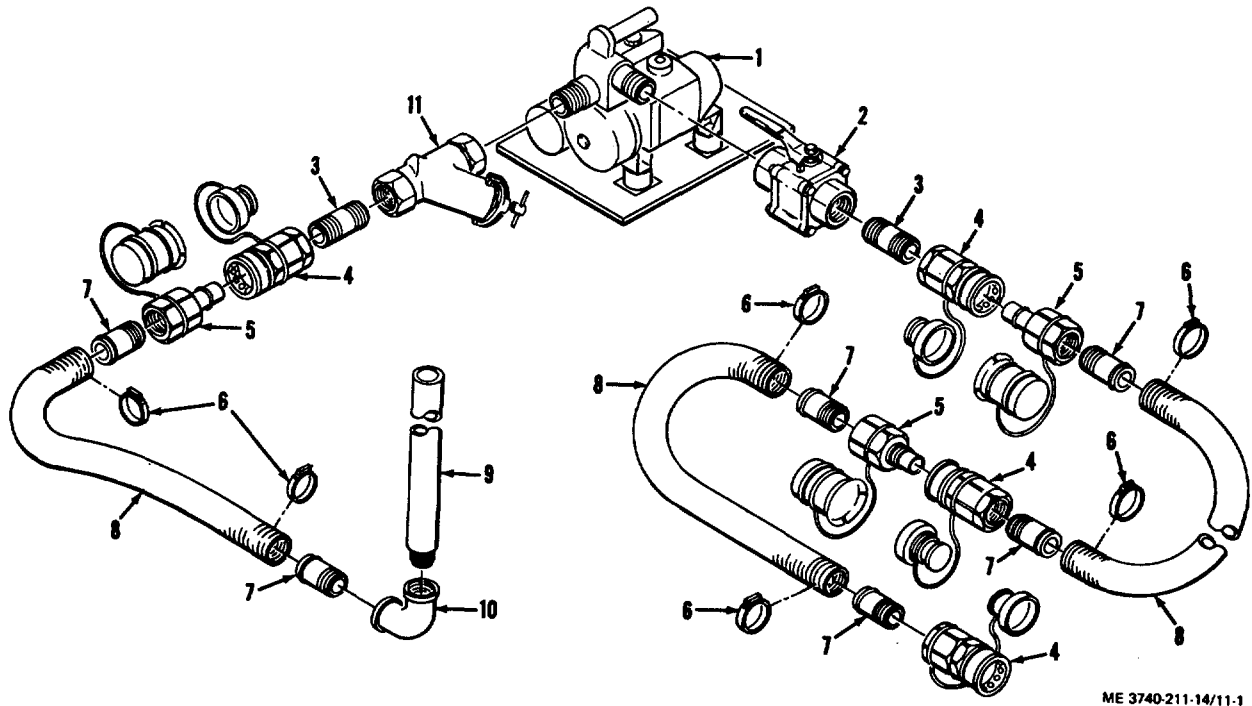

- | | | | |
|---------------|-------------------|------------|-----------------------|
| 1. Pump | 4. Valved coupler | 7. Adaptor | 10. Elbow |
| 2. Ball valve | 5. Valved nipple | 8. Hose | 11. Strainer assembly |
| 3. Nipple | 6. Hose clamp | 9. Pipe | |

Figure 11-1. Liquid loading system.

b. The major component of the liquid loading system is the pump. Refer to figure 11-2 for details and

important features of the pump.

- | | | | |
|-------------------------------|--------------------------------|----------------------------------|---|
| 1. Suction nipple | 10. Fan housing | 18. Muffler strap clamping screw | 25. Carburetor main (HI) mixture adjustment screw |
| 2. Discharge nipple | 11. Pump base | 19. Muffler | 26. Carburetor idle (LO) mixture adjustment screw |
| 3. Pump filler cap and gasket | 12. Fuel line connecting elbow | 20. Choke button | 27. Spare for drain or filler plug |
| 4. Carrying grip | 13. Bearing housing | 21. Exhaust manifold | |
| 5. Fuel line | 14. Back plate | 22. Spark plug | |
| 6. Air filter cover nut | 15. Pump wear plate | 23. Nameplate | |
| 7. Air filter cover | 16. Pump body | 24. Ignition ON/OFF switch | |
| 8. Fuel filler cap | 17. Pump drain plug and gasket | 28. Throttle button | |
| 9. Starter grip | | | |

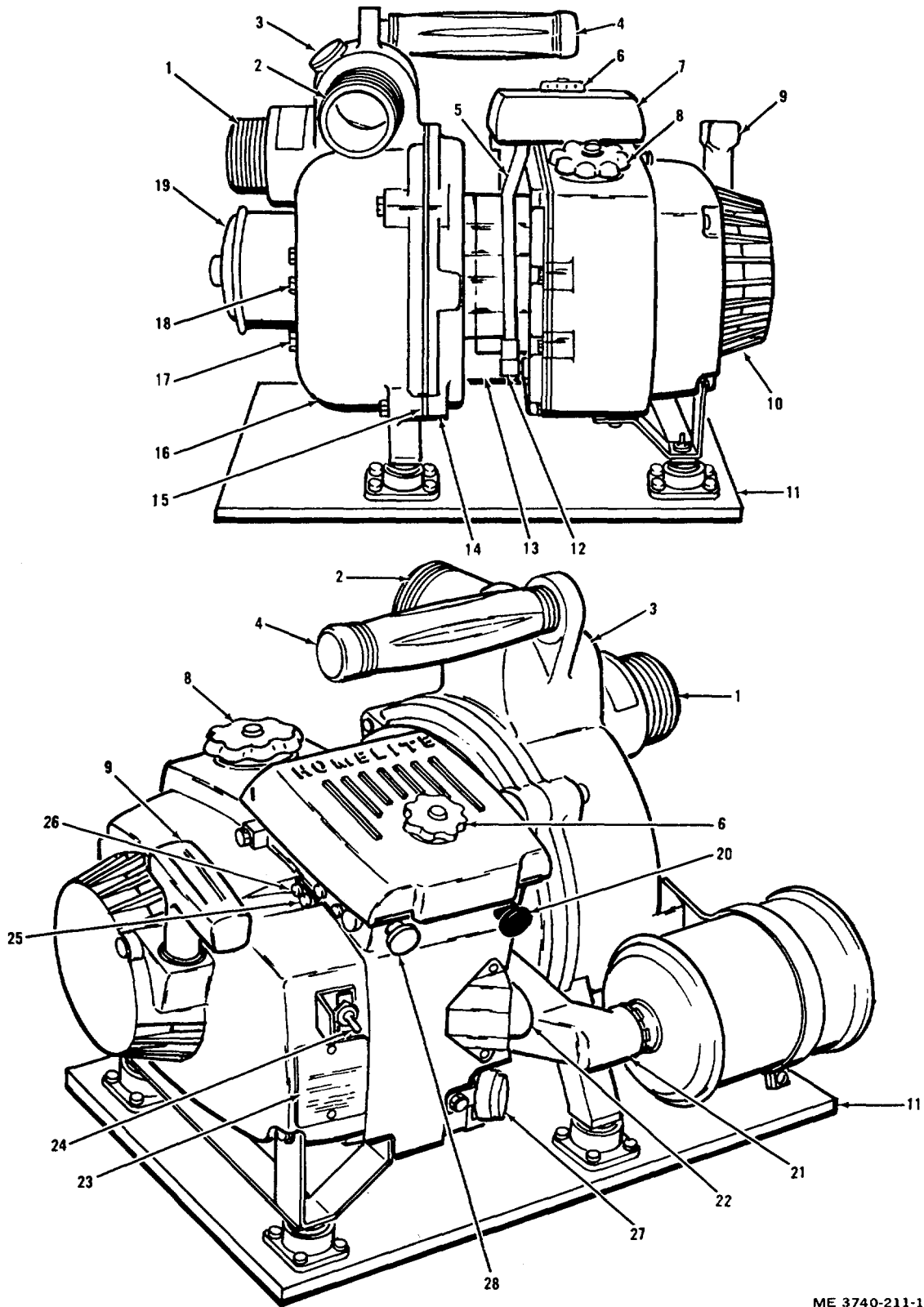

ME 3740-211-14/11-2

Figure 11-2. Pump assembly.

c. Refer to paragraph 11-1 for a general description of the liquid loading system. Figure 11-3 is a wiring schematic of the pump engine. Tabulated data for the liquid loading system is as follows:

(1) *Liquid loading system pump engine.*

ManufacturerHomelite
 Type.....Air-cooled
 Number of cylinders1
 Stroke cycle2
 FuelGasoline and oil, mixed
 Fuel tank capacity18 ounces liquid
 Piston displacement3.3 cubic inches
 Bore13/4 inches
 Stroke13/8 inches
 Compression ratio8:1
 Air cleanerDry type
 Ignition systemMagneto
 Type of lubricationOil mixed with fuel
 GovernorAir-vane type

(2) *Pump.*

ManufacturerHomelite
 TypeSelf-priming, centrifugal
 Rated speed (no load)6400 -- 6600 rpm
 DriveDirect

(3) *Engine accessories.*

(a) *Carburetor.*

ManufacturerTillotson
 ModelHS40A
 TypeDiaphragm with integral fuel pump

(b) *Ignition system.*

Type.....Magneto
 Manufacturer of magnetoWico
 Model.....FW-2782-C

(c) *Spark plug.*

ManufacturerChampion
 TypeXEJ-12
 Size14 millimeters

(d) *Adjustment data.*

Spark plug gap0.023-0.028 inch
 Magneto breaker point gap0.015 inch

(e) *Torque data.*

Spark plug250-300 lb-in.
 No. 8 Spinlock screws6 lb-in. min
 No. 10 Spinlock screws50 lb-in. min
 No. 12 Spinlock screws80 lb-in. min
 No. 4-40 ordinary screws4 3/4 lb-in. min
 No. 6-32 ordinary screws8 3/4 lb-in. min
 No. 8-32 ordinary screws18 lb-in. min
 No. 10-24 ordinary screws23 lb-in. min
 No. 10-32 ordinary screws32 lb-in. min

(4) *Quick-disconnect couplings.*

ManufacturerSnap-Tite, Inc.
 TypeDouble shut-off coupling: valved nipple and valved coupler

Size1 1/2 inch
 MaterialBrass
 SealsTeflon
 Working pressure270 psig
 Force to connect (at no

pressure37 pounds

(5) *Ball shutoff valve.*

ManufacturerWorcester Valve Co., Inc.
 Part Number1 1/4-436T-SE
 TypeManually operated, ball shutoff
 Size1 1/4 inch

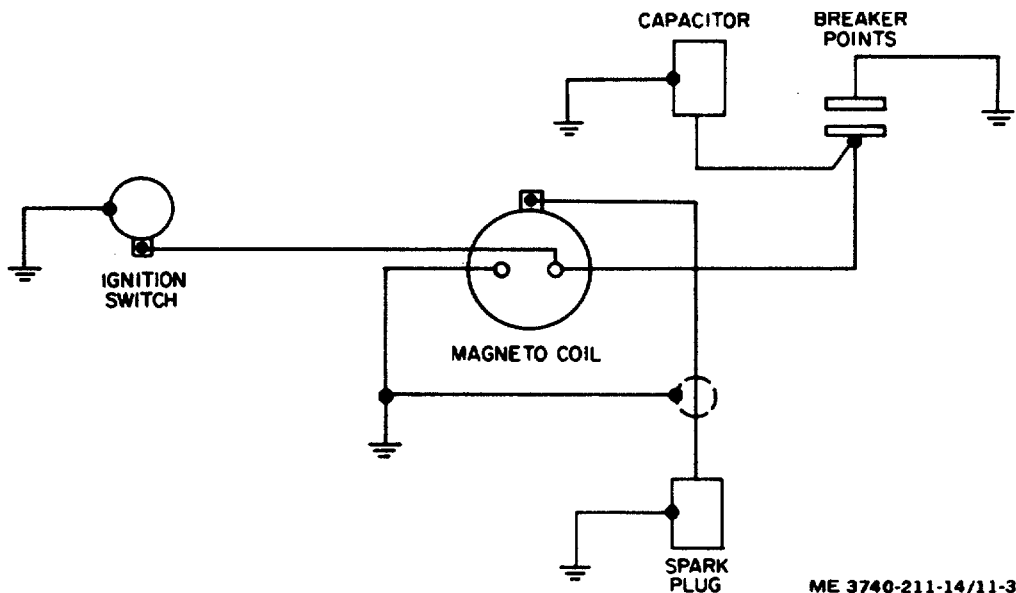

Figure 11-3. Liquid loading system pump engine - wiring schematic.

11-2. Scope

This chapter provides separate sections covering maintenance activities or the liquid loading system. Section I provides introduction, description and data, and scope; section II covers operator's maintenance; section III covers organizational level maintenance; and

section IV covers direct support/general support level maintenance.

Note:

Operating instructions for the liquid loading system are included with operating instructions for the insecticide sprayer system (ch. 2).

Section II. OPERATOR'S MAINTENANCE INSTRUCTIONS

11-3. General

a. Basic Issue Items. Tools, equipment, and repair parts issued with or authorized for the liquid loading system are listed in the basic issue items list, appendix C.

b. Repair Parts and Special Tools List. Refer to Repair Parts and Special Tools List Manual, TM 5-3740-211-24P, for a complete listing and illustrations of repair parts and special tools used in conjunction with the aircraft-mounted insecticide sprayer.

c. Lubrication Instructions.

(1) *General.* Keep all lubricants and fuel in closed containers and store in a clean, dry place away from external heat. Allow no dust, dirt, or other foreign material to mix with the lubricants. Keep all lubrication equipment clean and ready to use.

(2) *Cleaning.* Keep all external parts not requiring lubrication clean of lubricants and dirt.

(3) *Liquid loading system engine.* Lubrication of the liquid loading system engine is accomplished through the addition of oil into the gasoline supply (para 2-1, step b(2)).

(4) *Liquid loading system pump.* Lubrication of the liquid loading system pump is accomplished by the fluid being pumped (para 21, step b (5)).

11-4. Preventive Maintenance Checks and Services

a. General. Insure that the liquid loading system

is ready for use at all times. Inspect the equipment thoroughly so that defects may be found and fixed before they result in serious damage or failure. Perform necessary preventive maintenance checks and services listed in step b, following. Item numbers indicate the sequence of minimum inspection requirements. Record any defects noted during use of the equipment for repair to be made as soon as possible. Stop pump right away if a trouble is noted during pumping which would damage the equipment if pumping were continued.

b. Operator's Preventive Maintenance Checks and Services. Table 11-1 lists the operator's preventive maintenance checks and services.

c. Troubleshooting Chart. Table 11-2 contains a list of the operator's troubleshooting tasks for the liquid loading system. The chart serves only as a guide and does not mean that other troubles may not exist. Troubles beyond the scope of the operator/crew are contained in tables 11-4 and 11-7.

11-5. Maintenance of Liquid Loading System

a. General. Instructions in this paragraph are published to inform and guide the operator in maintaining the liquid loading system.

b. Air Cleaner Element Service.

(1) Clean the air cleaner element (3, fig. 11-19) as often as necessary to maintain engine power. Under very dusty operating conditions, the air cleaner element may require weekly or even daily cleanings. Never operate the engine without the air cleaner element.

Table 11-1. Operator's Preventive Maintenance Checks and Services.

Item No.	Interval					B - Before operation	A - After operation	Item to be inspected	Procedure	
	Daily			50	100	D - During operation	50 - After 50 hours operation			
	B	D	A			100 - After 100 hours operation				
01	X							Engine	Inspect for condition	
02				X				Air cleaner element	Remove and clean	11-5, step b
03					X			Air cleaner element	Replace	11-5, step b
04	X	X	X					Fuel lines	Check for damage	11-5, step c
05	X	X	X					Fuel level	Keep tank full	11-5, step d
06			X					Pump assembly strainer	Clean and decontaminate	
07			X					Pump assembly strainer	Remove and clean	

Table 11-2. Operator's Troubleshooting Chart - Liquid Loading System.

Malfunction	Probable cause	Corrective action
1. Engine will not start.	<ul style="list-style-type: none"> a. Ignition switch not at ON position. b. Low fuel level. c. Choke or throttle not set properly. d. Gas cap vent plugged. e. Vacuum in gas tank. 	<ul style="list-style-type: none"> a. Place ignition switch to ON position. b. Fill tank with fresh fuel/oil mixture. c. Adjust choke or throttle as required. d. Loosen cap or clean vent. e. Loosen cap.
2. Engine not running properly.	<ul style="list-style-type: none"> a. Low fuel level. b. Gas cap vent plugged. c. Air filter dirty. d. Choked engine. 	<ul style="list-style-type: none"> a. Fill tank with fresh fuel/oil mixture. b. Loosen cap or clean vent. c. Clean air filter. d. Push choke in.
3. Pump not pumping. water.	<ul style="list-style-type: none"> a. Pump not primed. b. Loose intake line connections. c. Pump plugged with contaminant. d. Inlet strainer clogged. e. Input valve closed (handle across tube). f. Supply fluid depleted. g. Pump defective. 	<ul style="list-style-type: none"> a. Fill pump with water. b. Tighten intake line connections. c. Stop engine; drain pump and fill with clear, clean water. d. Clean strainer. e. Open inlet valve. f. Change supply drums. g. Refer to organizational maintenance level.

(2) Clean the air cleaner element as follows (fig. 11-19):

(a) Loosen captive nut (1) and remove air cleaner element cover (2). Do not remove nut from cover.

CAUTION

Use care not to allow loose dirt or dust particles to fall into carburetor chamber.

(b) Before removing air cleaner element (3), remove all loose dirt or dust particles. Then remove air cleaner element.

(c) Slosh the element in clean solvent (not fuel mix), and dry thoroughly before use. If cleaning with solvent is not possible, clean the element by tapping against a flat surface or by blowing out dust or dirt with an air hose.

(d) Replace element after 100 hours of operation or when it appears clogged and cleaning will not restore engine power.

(e) Install air cleaner element, and secure in position with air cleaner element cover and captive nut.

c. *Fuel Line.* Inspect the fuel line (5 fig. 11-2) prior to use, and while engine is running. Observe for fuel leakage caused by cracked hose or loose connections. Stop pump right away if a leak occurs. Secure loose connections prior to restarting.

d. *Fuel Mixture and Level.* Check fuel level prior to starting pump engine, and fill upon completion of operations to prevent moisture condensation in fuel tank. Fill tank as instructed in paragraph 2-1, step b. Insure that proper fuel mixture is used to prevent engine malfunctions.

e. *Throttle Rod Friction.* If throttle rod (28, fig. 11-19) slips or "walks" during engine operation, tighten as follows:

(1) Position ignition switch at OFF to stop engine.

(2) Tighten two screws (34) as required to increase friction of throttle rod clamp (29).

(3) Resume normal operation.

f. *Pump Priming.* Since the fluid being pumped lubricates the pump and keeps it cool, make sure the pump contains water or the pumped fluid at all times while running. Refer to paragraph 2-1, step b (5) for pump priming procedure.

g. *Inlet Strainer, Hoses, and Couplings.*

WARNING

Insecticide spray fluids are poisonous and should be handled with care. Avoid splashing fluid or prolonged contact or breathing of fumes. Wash hands before smoking or eating, after contact with insecticide fluid.

Prior to operating the equipment, inspect the inlet strainer, hoses, and couplings for condition and serviceability.

(1) *Strainer.* Loosen the screw assembly (2, fig. 11-4) on strainer body (7). Remove cap (4), O-ring (5), and screen (6). Clean the screen by sloshing in clean, running water. Inspect the O-ring, and replace if defective.

(2) *Hoses.* Inspect the hose assemblies for breaks, cracks, or loose connections. Replace any hose assembly found to be defective.

(3) *Valved couplers.* Inspect valved coup-

lers and nipples (4 and 5, fig. 11-1) for condition and cleanliness. Internal sealing valves must be closed when coupling halves are separated. Make sure coupling halves are fully engaged and locked when connected. Keep dust caps or dust plugs in place when couplers are separated. Remove any

foreign particles which may cause leakage past sealing valves.

h. Ignition Cable. Check ignition cable prior to starting engine to insure that connections are tight and that insulation is not cracked or shorted out.

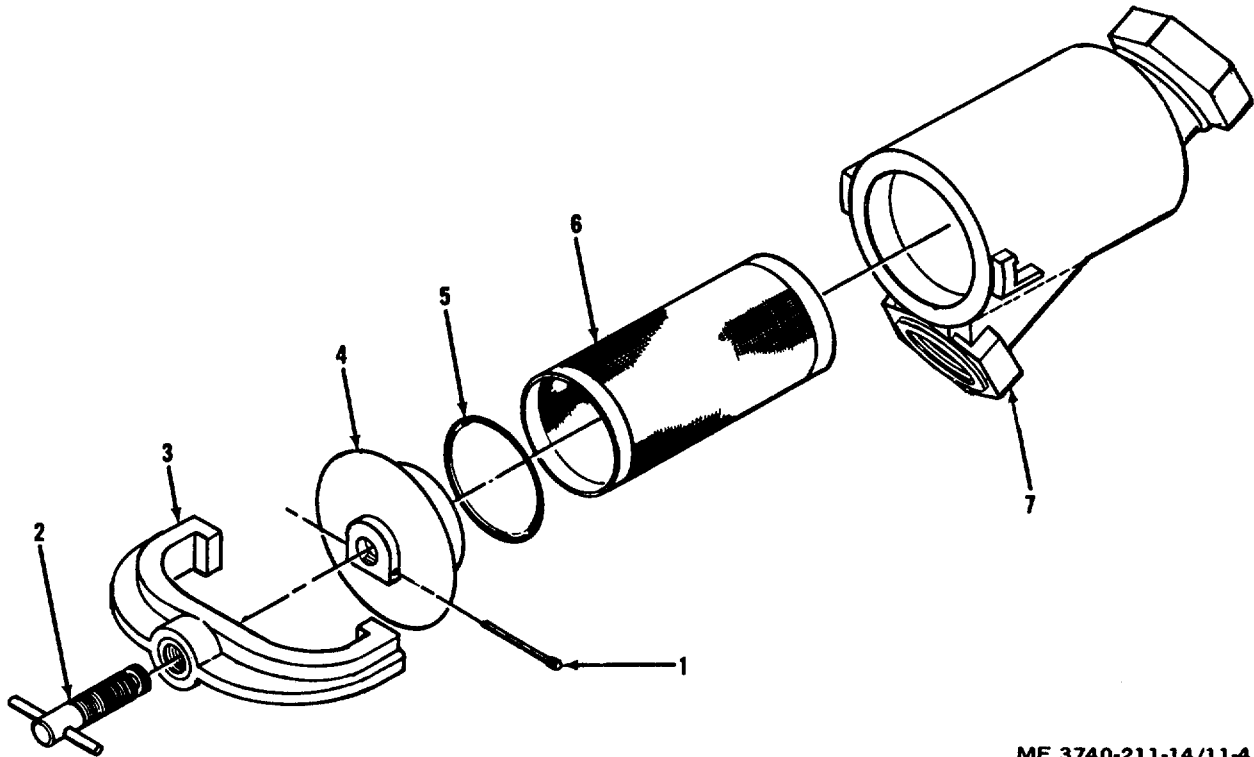

ME 3740-211-14/11-4

- | | | | |
|-------------------|---------|-----------|---------|
| 1. Cotter pin | 3. Yoke | 5. O-ring | 7. Body |
| 2. Screw assembly | 4. Cap | 6. Screen | |

Figure 11-4. Inlet strainer - exploded view.

Section III. ORGANIZATIONAL MAINTENANCE INSTURCTIONS

11-6. Repair Parts, Special Tools, and Equipment

a. Tools and Equipment. Tools, equipment, and spare parts issued with or authorized for the liquid loading system are listed in the basic issue items list, appendix C.

b. Special Tools and Equipment. The only

special tool required for organizational maintenance personnel for maintenance of the liquid loading system is a muffler cleaning tool. This tool can be fabricated as shown in figure 11-5. The tool is used to clean out clogged perforations of the muffler as described in paragraph 11-8c.

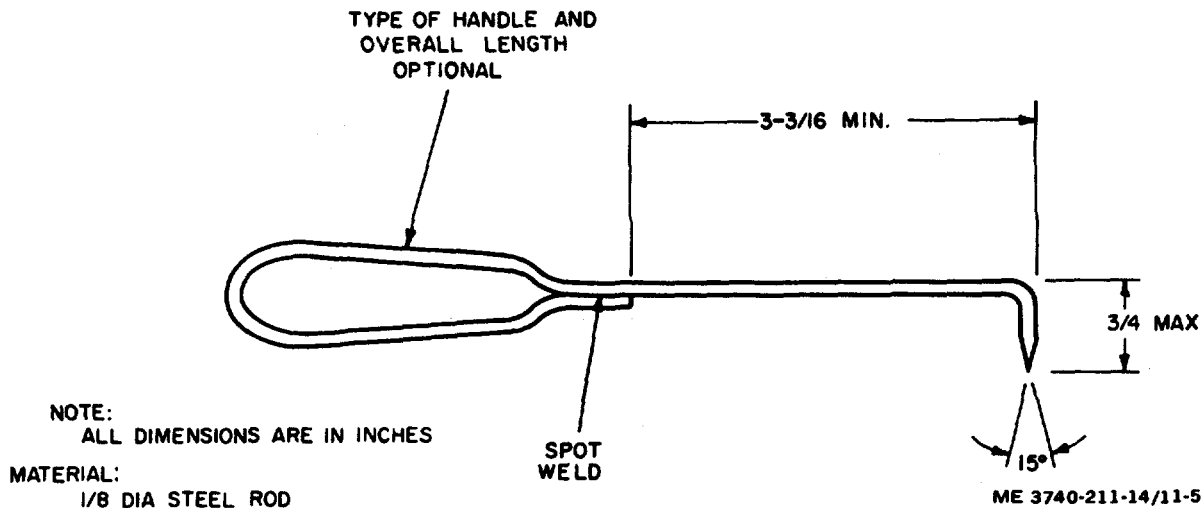

Figure 11-5. Fabrication of muffer cleaning tool.

c. *Maintenance Repair Parts.* Repair parts and equipment covering organizational maintenance for the liquid loading system are listed and illustrated in TM 5-3740-211-24P.

11-7. Preventive Maintenance Checks and Services

a. *General.* Insure that the liquid loading system is ready for operation at all times. Inspect the equipment systematically so that defects may be discovered and corrected before they result in serious damage or failure. Perform necessary preventive maintenance checks and services listed in step b, following. Item numbers indicate the sequence of minimum inspection requirements.

b. *Organizational Preventive Maintenance Checks and Services.* Table 11-3 lists the preventive maintenance checks and services applicable to organizational maintenance.

c. *Troubleshooting Chart.* Table 11-4 contains a tabulation of troubleshooting activities pertinent to organizational maintenance. The chart serves only as a guide and does not preclude the possibility of other troubles existing.

Note:

A quick check of pump condition for troubleshooting purposes is to disconnect shielded ignition cable from spark plug and hold end of the cable approximately 1/4 inch

from rear end of spark plug while pulling starter handle (this may require two men) If sparks do not jump, the trouble is in the electrical system. (Report this condition to direct support maintenance.) If sparks jump, replace spark plug. If this does not correct the problem, the trouble is in the fuel system. Check fuel lines, fuel tank, and carburetor.

11-8. Maintenance of Liquid Loading System

a. *General.* Instructions in this paragraph are to inform and guide organizational maintenance personnel in maintaining the liquid loading system.

b. *Spark Plug Service.*

(1) A fouled or dirty spark plug which has caused trouble will often prove serviceable after it has been thoroughly cleaned, washed, and properly gapped.

CAUTION

When setting spark plug gap be sure not to damage electrodes or insulator.

(2) Service spark plug as follows:

(a) Carefully unscrew spark plug (HI-tension) lead (43, 11-15) from end of spark plug (41, fig. 11-20) using a 3/4-inch open end wrench.

(b) Using a 13/16-inch deep socket wrench, remove the spark plug and gasket (41 and 42).

Table 11-3. Organizational Preventive Maintenance Checks and Services.

Item No.	Interval (hours)			Item to be inspected	Procedure
	50	100	500		
01	X			Spark plug	Clean and regap
02		X		Spark plug	Replace
03	X			Cylinder fins	Clean cylinder fins
04	X			Cylinder exhaust port	Clean
05	X			Exhaust manifold	Clean
06	X			Muffler	Clean
07	X			Fuel lines	Repair if damaged
08		X		Magneto breaker points	Clean and regap
09		X		Cylinder chamber and piston dome	Remove and clean
10			X	Condenser and breaker points	Change points and set gap

Table 11-4. Organizational Troubleshooting Chart - Liquid Loading System.

Malfunction	Probable cause	Corrective action
1. Engine fails to start or starts with difficulty.	<ul style="list-style-type: none"> a. Ignition switch not set correctly. b. No fuel in tank. c. Excessive carbon on spark plug. d. Spark plug gap incorrect. e. Muffler clogged. f. Exhaust manifold or cylinder exhaust port clogged. g. Air cleaner element clogged. h. Water or dirt in fuel tank. i. Engine needs choking. j. Fuel tank cap valve clogged. 	<ul style="list-style-type: none"> a. Set ignition to ON. b. Fill fuel tank. c. Clean or replace spark plug (11-8b). d. Regap spark plug (11-8b). e. Clean muffler (11-8c). f. Clean exhaust manifold and cylinder exhaust port (11-8d). g. Clean or replace air cleaner element (11-5b (2)). h. Drain, clean, and refill fuel tank with correct fuel mixture. i. Pull choke button out and restart. j. Remove cap and restart; if engine runs better, replace fuel tank cap.
2. Engine overheats or lacks power.	<ul style="list-style-type: none"> a. Incorrect fuel mixture. b. Choke open. c. Carburetor improperly adjusted. d. Muffler, exhaust manifold, or cylinder exhaust port clogged. e. Cylinder fins clogged. f. Inadequate ventilation. g. Engine or pump parts binding. h. Air leak in fuel line. i. Ruptured fuel pump diaphragm. j. Spark plug fouled. 	<ul style="list-style-type: none"> a. Drain, clean, and refill tank with correct fuel mixture. b. Push in choke button fully to close choke. c. Adjust carburetor. d. Clean muffler (11-8c) exhaust manifold, and cylinder exhaust port (11-8d). e. Clean cylinder fins. f. Provide adequate cooling air flow. g. Perform overhaul (report this condition to direct support maintenance). h. Inspect and replace fuel line if required. i. Disassemble carburetor and correct trouble. j. Clean and regap or replace spark plug (11-8b).
3. Engine misfires.	<ul style="list-style-type: none"> a. Choke open. b. Carburetor improperly adjusted. c. Spark plug fouled. d. Ignition cable, ignition coil, or breaker points defective. 	<ul style="list-style-type: none"> a. Push in choke button fully to close choke. b. Adjust carburetor (11-8f). c. Clean and regap or replace spark plug (11-8b). d. Replace defective parts.
4. Excessive smoke from muffler.	<ul style="list-style-type: none"> a. Excessive oil in fuel mixture. b. Carburetor set too rich. 	<ul style="list-style-type: none"> a. Drain fuel tank and fill with correct fuel mixture. b. Adjust carburetor (11-8f).

Table 11-4. Organizational Troubleshooting Chart - Liquid Loading System (Continued).

Malfunction	Probable cause	Corrective action
5. No fluid being pumped.	<ul style="list-style-type: none"> a. Ball valve closed. b. Pump not primed. c. Inlet strainer clogged. d. Fluid source empty or inlet pipe clogged. e. Leaks in suction hose or couplings. f. Pump faulty. 	<ul style="list-style-type: none"> a. Open ball valve. b. Prime pump. c. Remove and clean or replace strainer screen (11-5b). d. Check fluid source for cause. e. Inspect and repair or replace hose or couplings. f. Repair pump (report to direct support maintenance).
6. Restricted fluid flow.	<ul style="list-style-type: none"> a. Inlet strainer clogged. b. Fluid source low or inlet pipe clogged. c. Leaks in suction hose or couplings. d. Pump faulty or engine not up to speed or power. 	<ul style="list-style-type: none"> a. Remove and clean or replace strainer screen (11-5b). b. Check fluid source for cause. c. Inspect and repair or replace hose or couplings. d. Repair pump (report to direct support maintenance).

(c) Inspect the spark plug and clean or replace as necessary. Replace spark plug and gasket after 100 hours of operation or if cleaning and regapping the plug does not return it to serviceable condition.

(d) Clean the spark plug by wire-brushing and by digging out carbon around the insulator with a sharp instrument.

(e) Using a 0.035-inch feeler gage, set the spark plug gap.

(f) Place gasket (42, fig. 11-20) over spark plug threads, and install spark plug. Tighten spark plug to a torque of 250 to 300 lb-in. using a 13/16-inch deep socket and torque wrench.

(g) Replace spark plug lead (43, fig. 11-15) using a 3/4-inch open end wrench over end terminal of spark plug. Make sure plug lead is fully installed and that no dirt is trapped in spark

plug when installing. Check to see that terminal end of ignition wire (43) is fully inserted in spark plug boot.

c. Muffler Service.

(1) Loosen screw of muffler strap (21, fig. 11-22). Remove muffler strap from muffler (20) and muffler bracket (22).

(2) Loosen locknut on inlet of muffler (20) and unscrew muffler from exhaust manifold (40, fig. 11-20).

(3) Using a scribe or the fabricated muffler cleaning tool (fig. 11-5), clean out all of the perforations of the muffler by inserting the tool into each end and picking out carbon deposits (fig. 11-6).

Note:

It is necessary to clean from both ends because of the solid baffle in the center of the muffler.

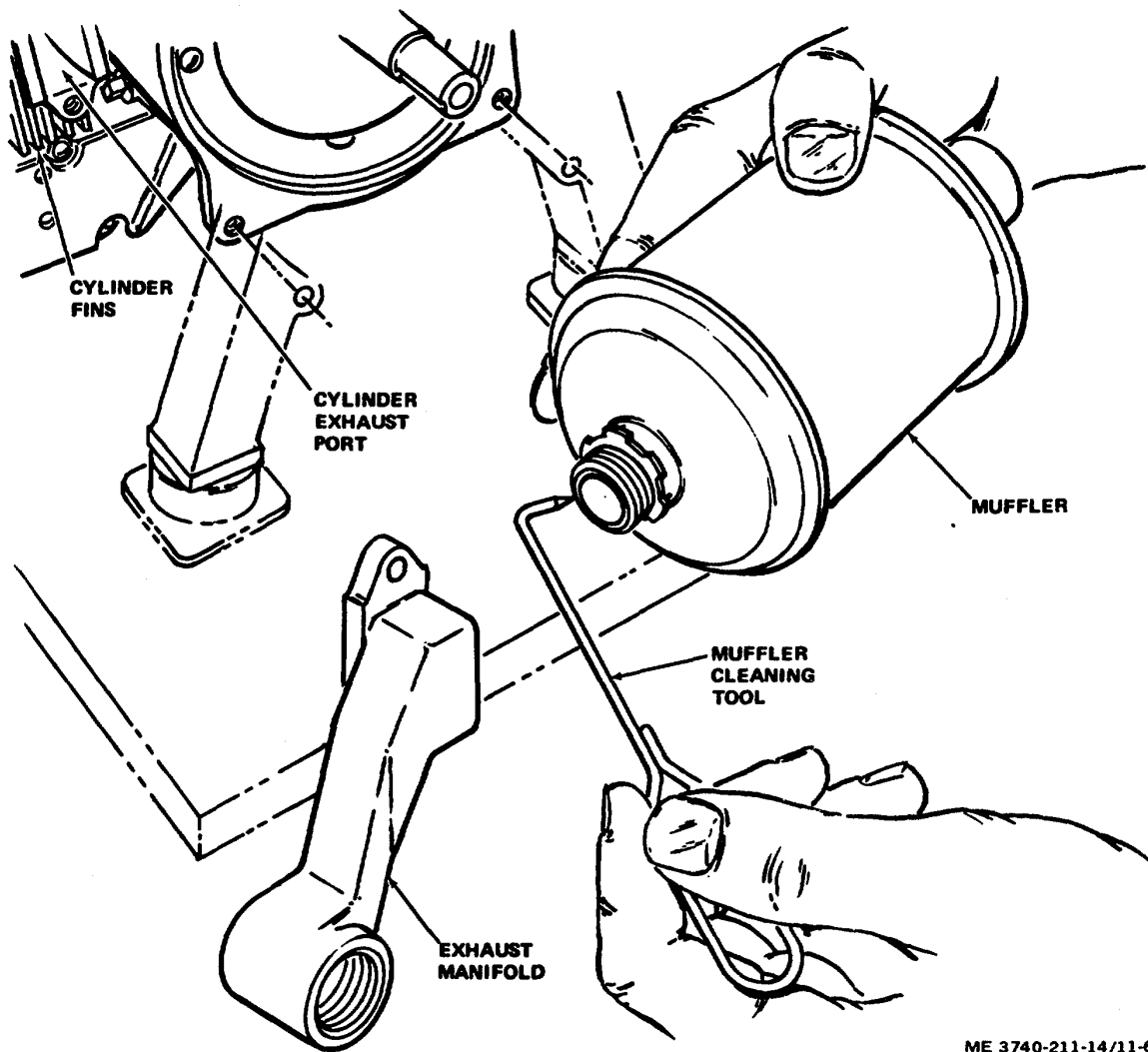

ME 3740-211-14/11-6

Figure 11-6. Muffler cleaning.

(4) Before installing the muffler, clean the exhaust manifold and cylinder exhaust port (ref step d, following).

(5) Replace muffler by screwing muffler (20, fig. 11-22) into exhaust manifold (40, fig. 11-20) and securing locknut on muffler inlet threads. Place muffler strap (21, fig. 11-22) over muffler and over muffler bracket (22). Secure strap adjusting screw to retain muffler snugly in place.

d. Cylinder Exhaust Port and Exhaust Manifold Service.

(1) Remove muffler as instructed in c, steps 1 and 2, preceding.

(2) Remove the two screws (37, fig. 11-20),

and remove exhaust manifold (40) from cylinder (43).

(3) Put piston and pin (34) to top dead center position to cover the cylinder ports so that dirt or dust cannot fall inside.

(4) Using a wooden or plastic scraper, carefully remove the carbon deposits from the cylinder exhaust port. Be careful not to scratch the piston or damage the chamfered edges of the cylinder exhaust port. Clean the cylinder fins and blow out all loose particles from the exhaust manifold and cylinder exhaust port before reinstalling the exhaust manifold and muffler.

(5) Attach exhaust manifold (40) to the cylinder (43) using screws (37). Install muffler

(20, fig. 11-22) to exhaust manifold as instructed in step c (5), preceding.

e. *Fuel Line Replacement.* If replacement of the flexible fuel line (19, fig. 11-20) is required, heat ends of the new fuel line in a pot of boiling water until they are soft. While soft, stretch ends over the fitting as required. This softening is required only on new fuel lines. Once they are stretched, they will retain their shape.

f. *Carburetor Adjustment (fig. 11-7).*

Note:

Before changing the carburetor mixture adjustments, be sure the tank is full of clean, fresh, properly mixed fuel. Then clean the air filter, and leave the filter and cover off until the carburetor has been adjusted.

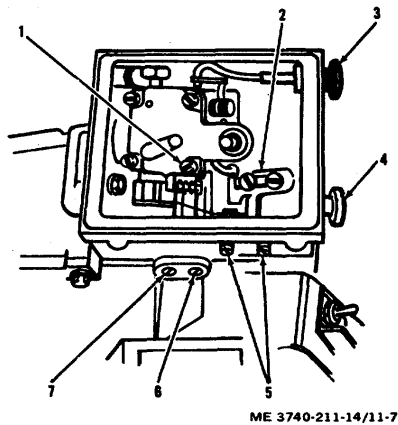

- | | |
|---|--|
| 1. Idle speed adjustment screw | 5. Throttle rod adjustment screws |
| 2. Governed speed adjustment clamp and screws | 6. Main mixture adjustment needle (HI) |
| 3. Choke button | 7. Idle mixture adjustment needle (LO) |
| 4. Throttle button | |

Figure 11-7. Carburetor adjustment controls.

(1) Remove and clean the air cleaner element as instructed in paragraph 11-5, step b (2).

CAUTION

Use care when adjusting needles not to jam needles in their orifices.

(2) Very gently turn the idle mixture adjustment needle (7), and the main mixture adjustment needle (6) until they just close against their seats. Then open both needles one turn from the gently closed position.

(3) Push the throttle button (4) all the way in. Start engine and pump water at open discharge. When engine is fully warmed up, adjust the main mixture adjustment needle for the highest pumping speed obtainable. Then, open the needle 1/8 turn more.

CAUTION

The screws holding the governed speed adjust clamp (2) should never be loosened, except by direct support or general support personnel with proper test equipment available.

(4) Pull the throttle button (4) all the way out, and adjust the idle mixture adjustment needle (7) for the smoothest and highest speed obtainable. If this speed is either too high or too low, adjust speed by means of the idle speed adjustment screw (1).

Note:

Because main and idle mixture adjustment needles are interdependent, some readjustment under full load conditions may be necessary.

(5) Recheck adjustments under full load conditions as in steps (2), (3), and (4), preceding. Be sure settings are correct before reinstalling the air filter and cover.

(6) Reinstall air cleaner filter element and cover as instructed in paragraph 11-5, step b (2) (e).

g. *Removal and Replacement of Hoses, Couplings, Strainer, and Ball Valve (fig. 11-1).*

(1) All threaded connections of the pump (1), hoses (8), couplers (4), strainer assembly (11), ball valve (2), and valved nipples (5), use pipe threads. Removal and replacement procedures are therefore identical for each. To remove, use a pipe wrench, strap wrench, or vise to hold one part, while unscrewing the mating part with a second wrench.

(2) Disconnect mated valved couplers by pulling back the retaining ring of the female half of the coupler, and pull the coupling halves apart.

(3) Clean threads of all components before reattaching. Remove all dirt, spray fluid residue, tape, or lubricants.

(4) Apply a new layer of Teflon tape per Military Specification MILT-27730, to pipe threads before reattaching.

(5) Connect mating parts and screw down fairly snug. Since pipe threads are tapered, it is not necessary to overtighten them. However, do not back threads off from their tightest position, as a leak may occur.

**Section IV. DIRECT SUPPORT AND GENERAL SUPPORT
MAINTENANCE INSTRUCTIONS**

11-9. General

a. *Scope.* These instructions are published for the use of direct support and general support maintenance personnel maintaining the liquid loading system. They provide information on the maintenance of the equipment which is beyond the scope of tools, equipment, personnel, or sup-

plies normally available to using organizations.

b. *Repair and Replacement Standards.* Table 11-5 lists manufacturer's sizes, tolerances, desired clearances, and maximum allowable wear and clearances pertaining to the liquid loading system pump engine.

Table 11-5. Repair and Replacement Standards

Component	Manufacturer's dimensions and tolerances in inches		Desired clearance		Maximum allowable wear and clearance
	Minimum	Maximum	Minimum	Maximum	
Crankshaft:					
Needle bearing journals	0.6245	0.6250	0.0005	0.0010	0.0005
Connecting rod roller journal	0.5565	0.5570		-----	0.0005
Connecting rod needle bearing journal	0.5615	0.5625		-----	0.0010

11-10. Special Tools and Equipment

a. *Special Tools and Equipment.* No special tools and equipment are required.

b. *Specially Designed Tools and Equipment.* The specially designed tools listed in table 11-6 and illustrated in figures 11-8 through 11-14 are

for direct and general support maintenance personnel performing major overhaul work on the liquid loading system pump. Tools listed in table 11-6 are not available for issue, .but can be fabricated by qualified maintenance personnel for expedient repair by utilization.

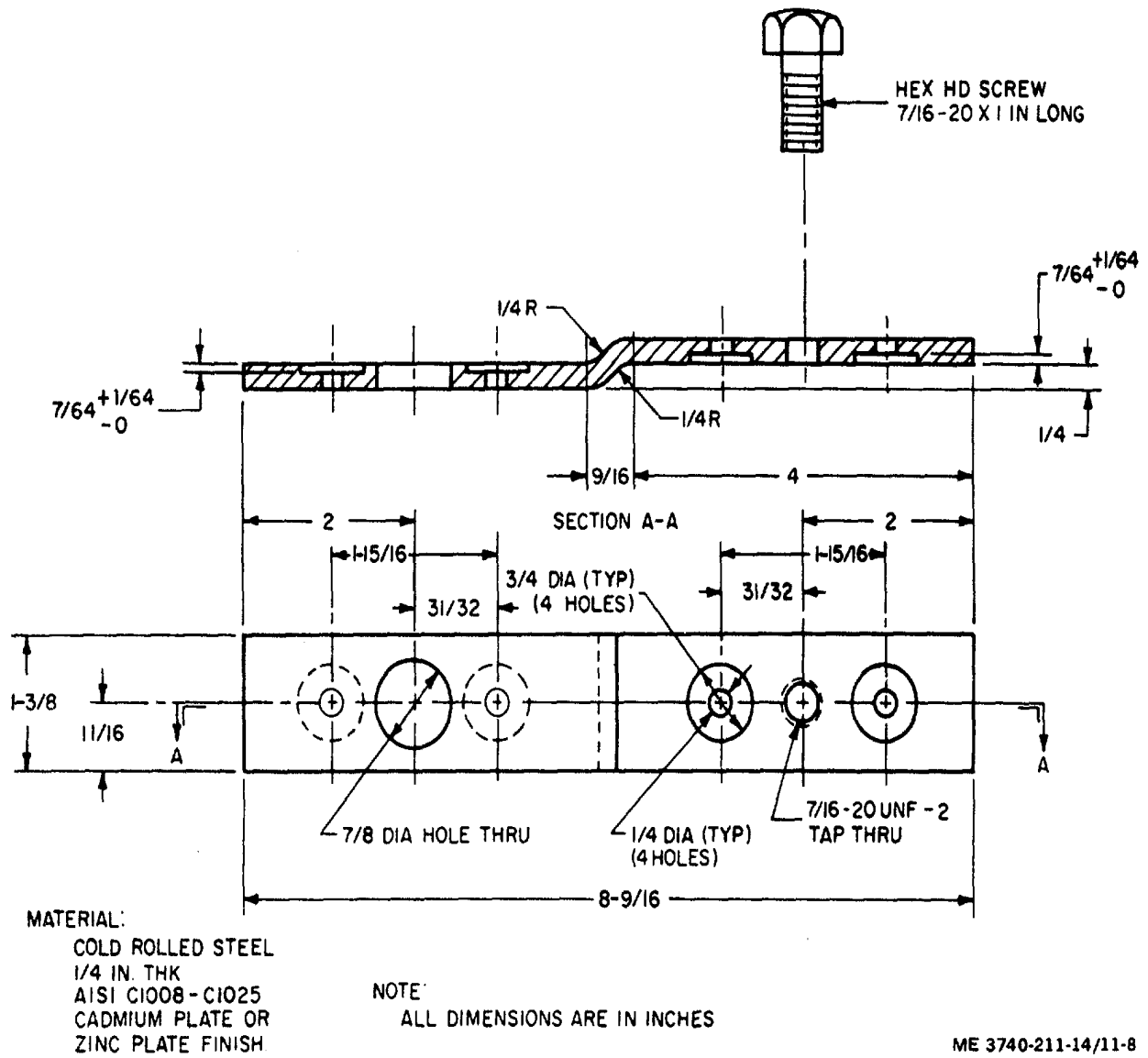
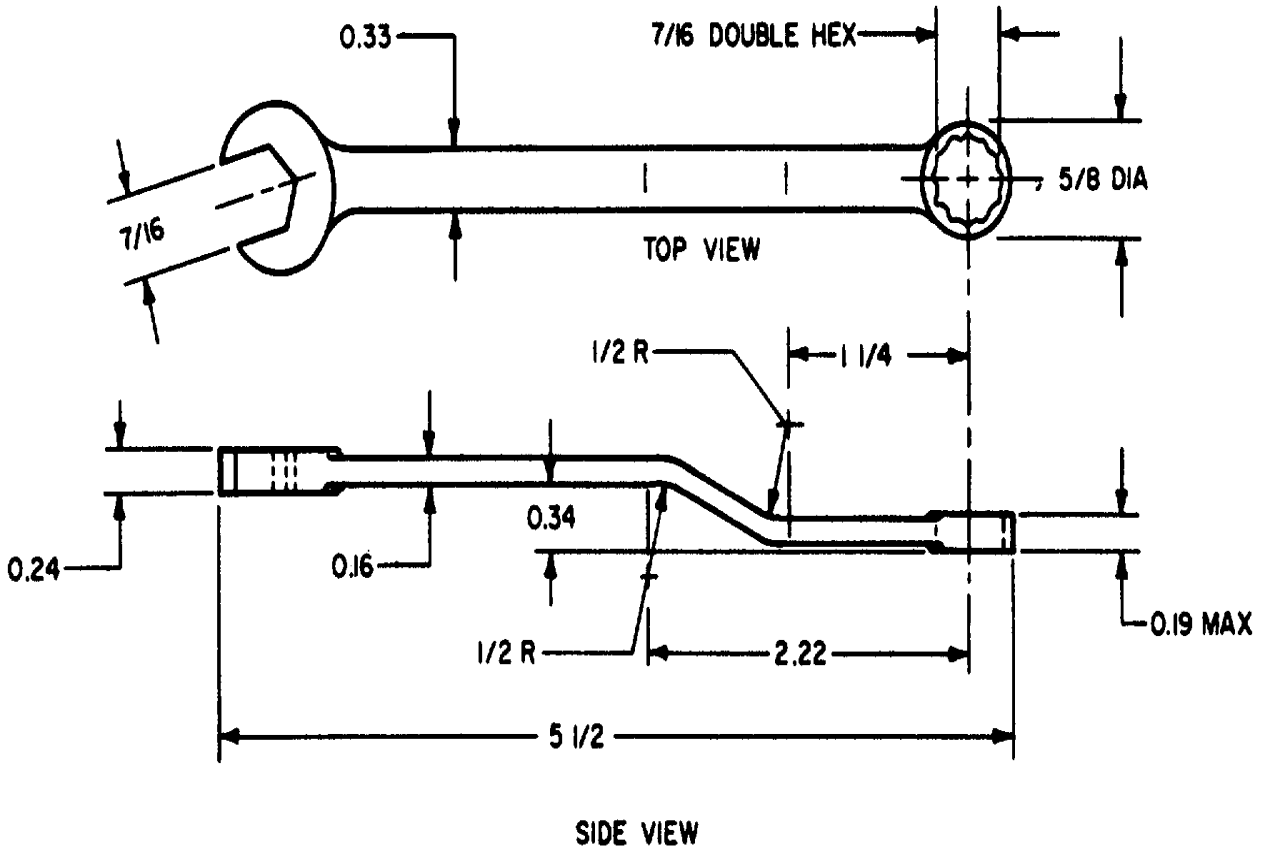

Figure 11-8. Fabrication of rotor locking tool.



MATERIAL:

4140 STEEL
 ROCKWELL "C"-45-47
 BLACK OXIDE FINISH

NOTE:

ALL DIMENSIONS ARE IN INCHES.

ME 3740-211-14/11-9

Figure 11-9. Fabrication of offset wrench.

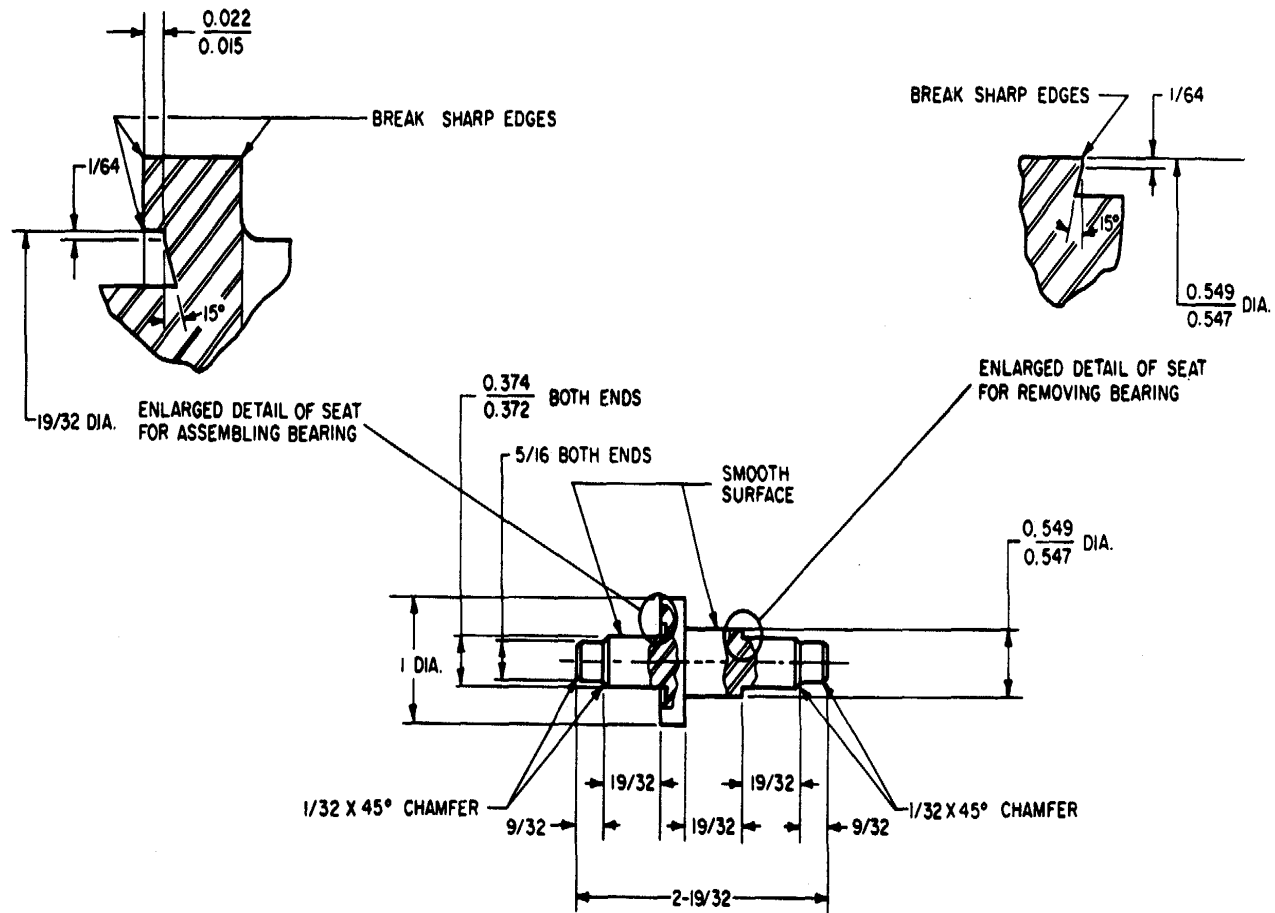

MATERIAL.

COLD ROLLED STEEL AISI B1112-B1113 ROCKWELL "15N"-85 MIN.
 CADMIUM PLATE OR ZINC PLATE FINISH, RELIEVE AT 375° F
 FOR 4 HOURS AFTER PLATING.

NOTE:

ALL DIMENSIONS ARE IN INCHES

ME 3740-211-14/11-10

Figure 11-10. Fabrication of needle bearing assembly tool.

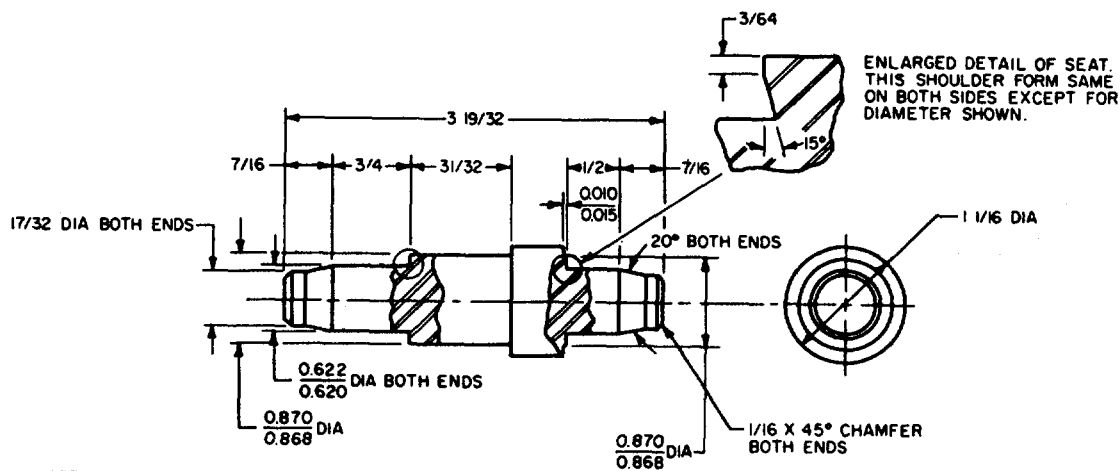

MATERIAL:
 COLD ROLLED STEEL A151 B1112-B1113
 ROCKWELL "15N" - 85 MIN.
 CADMIUM PLATE OR ZINC PLATE FINISH
 RELIEVE AT 375°F FOR 4 HOURS AFTER PLATING.

NOTE:
 ALL DIMENSIONS ARE IN INCHES.

ME 3740-211-14/11-11

Figure 11-11. Fabrication of bearing and seal tool.

Table 11-6. Fabricated Special Tools

Item	Reference		Use
	Figure Number	Paragraph	
Rotor locking tool	11-8	11-12c, 11-12d	Hold magneto rotor when removing or installing rotor shaft nut or pump impeller.
Offset wrench	11-9	11-13d	Remove and install cylinder nuts.
Needle bearing assembly tool	11-10	11-13d	Remove and install needle bearing in connecting rod (piston end)
Bearing and seal tool	11-11	11-13d, 11-13f	Remove needle bearing and seal from crank-case; remove and install needle and seal in pump bearing housing, and install needle bearing in crankcase and pump bearing housing.
Seal assembling plug	11-12	11-13d, 11-13f	Install seals in crankcase, and pump bearing housing.
Seal assembling sleeve	11-13	11-12c, 11-13d	Protect seal when installing crankshaft into crankcase.
Piston pin removal tool	11-14	11-13d	Remove piston pin from piston.

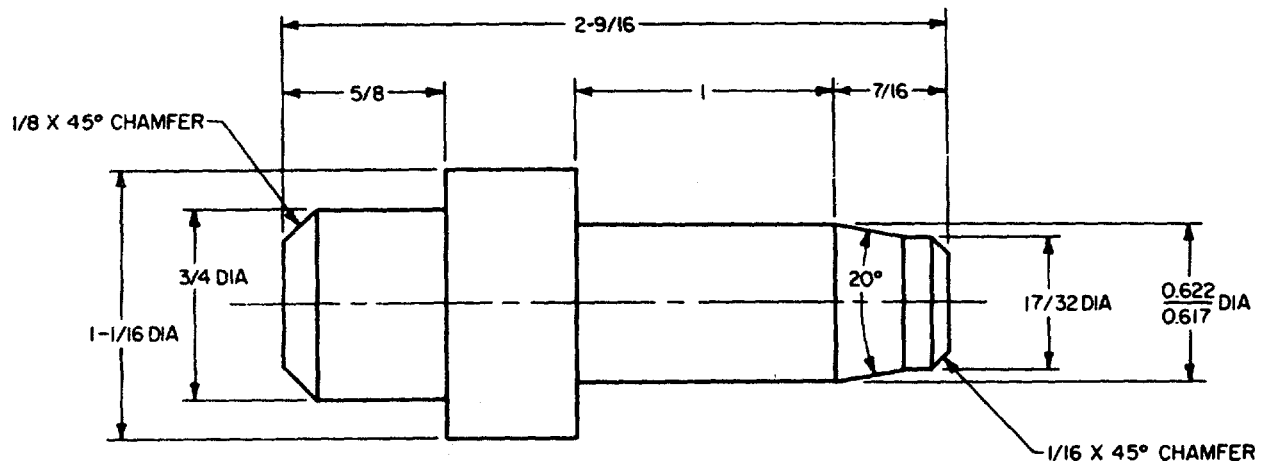

MATERIAL:

COLD ROLLED STEEL AISI B1112-C1117 OR C1018
 ROCKWELL "15N" - 85 MIN.
 CADMIUM PLATE OR ZINC PLATE FINISH
 RELIEVE AT 300° F FOR 4 HOURS MIN. AFTER PLATING.

NOTE:

ALL DIMENSIONS ARE IN INCHES.

ME 3740-211-14/11-12

Figure 11-12. Fabrication of seal assembling plug.

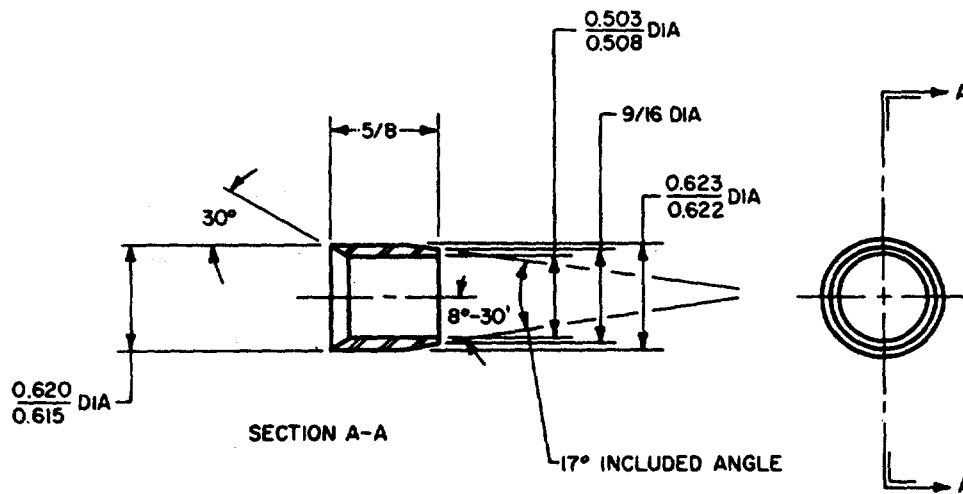

MATERIAL:

COLD ROLLED STEEL AISI B1112-B1113
 CADMIUM PLATE OR ZINC PLATE FINISH

NOTE:

ALL DIMENSIONS ARE IN INCHES.

ME 3740-211-14/11-13

Figure 11-13. Fabrication of seal assembling sleeve.

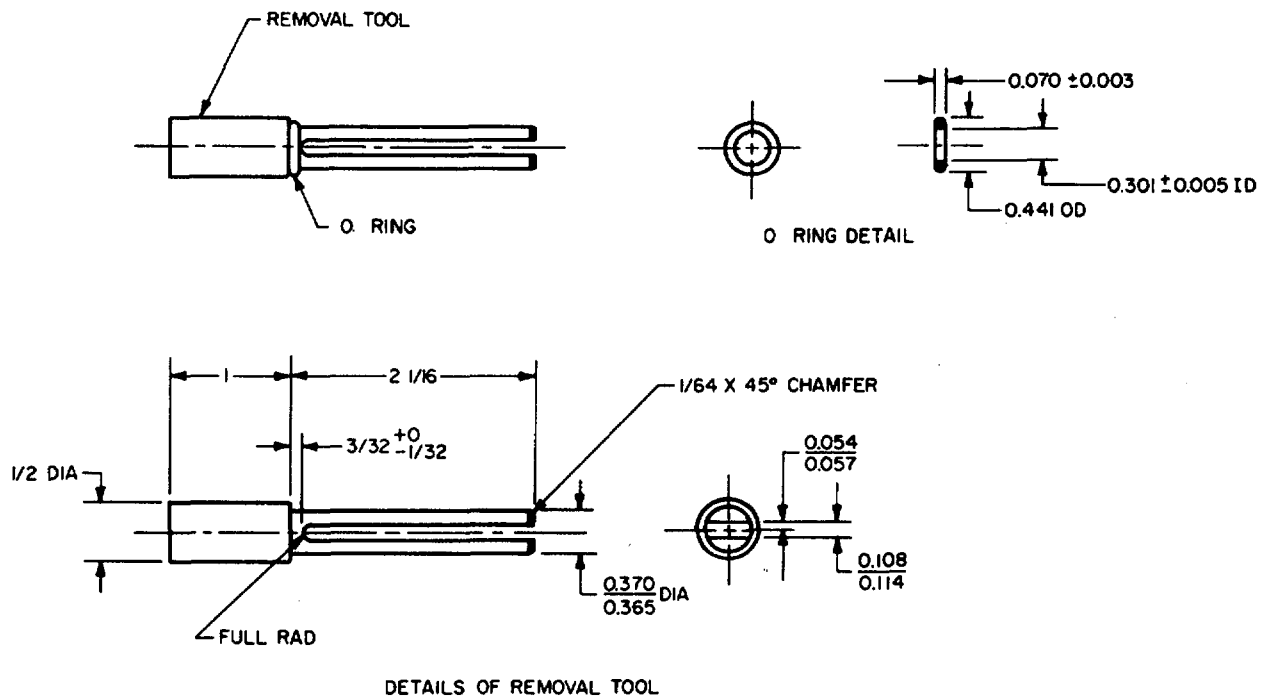

MATERIAL:
 TOOL STEEL
 ROCKWELL "C" 55-60
 O RING-BLACK SYNTHETIC RUBBER
 ASTM SB720 BE₁E₃F₁

NOTE:
 ALL DIMENSIONS ARE IN INCHES.

ME 3740-211-14/11-14

Figure 11-14. Fabrication of piston pin removal tool.

11-11. Troubleshooting

Table 11-7 contains a tabulation of troubleshooting activities pertinent to direct support and general support maintenance. The chart serves only as a guide, and does not preclude the possibility of other troubles existing.

11-12. Removal and Installation of Major Components

a. *General.* The major components which make up the liquid loading system pump, and which can be easily removed as major components, are the starter fan housing, pump, ignition parts, and carburetor.

Note:

The crankshaft, connecting rod, and piston removal and installation are covered in paragraph 11-13d.

Table 11-7. Direct Support and General Support Troubleshooting Chart - Liquid Loading System

Malfunction	Probable cause	Corrective action
1. Engine fails to start or starts with difficulty.	<ul style="list-style-type: none"> a. Breaker points defective or improperly gapped. b. Condenser defective. c. Carburetor dirty or defective. d. Starter binding or defective e. Spark plug overheated (indicated by burned electrode; insulator tip light gray or chalk white). f. Spark plug: wet, fouled indication; insulator tip black, damp oily film over firing end; carbon layer over entire nose. g. Spark plug: oxide fouled indication (electrode covered with ash-like deposits). 	<ul style="list-style-type: none"> a. Regap or replace breaker points (11-13b). b. Replace condenser (11-13b). c. Clean or replace defective carburetor parts (11-12c). d. Check and correct trouble (11-13a). e. Check for: <ul style="list-style-type: none"> 1. Clogged muffler (11-8), or exhaust port or exhaust manifold (11-8d). 2. Air leak in fuel line (11-5c). 3. Ruptured fuel pump diaphragm in carburetor (11-13e). f. Check for incorrect carburetor adjustment (11-8f); air cleaner element clogged (11-5b); wrong fuel mix 11-5d); faulty ignition parts (11-12d and 11-13b). g. Check for excessive combustion chamber deposits (11-13d); Clogged muffler (11-8c); clogged cylinder exhaust port or manifold (11-8d); use of non-recommended oil, or too much oil in fuel mix (11-5d).
2. Engine lacks power.	<ul style="list-style-type: none"> a. Piston rings worn. b. Cylinder worn or scored. c. Damaged bearings. d. Carburetor dirty. e. Parts binding. f. Damaged or leaking crankcase. 	<ul style="list-style-type: none"> a. Replace piston rings (11-13d). b. Replace cylinder (11-13d). c. Replace bearings (11-13d). d. Clean or replace defective carburetor parts (11-13e). e. Check and replace damaged parts (11-13d). f. Check and correct trouble (11-13d).
3. Engine speed erratic or pump output erratic.	<ul style="list-style-type: none"> a. Parts binding or worn in pump. 	<ul style="list-style-type: none"> a. Check and replace damaged parts (11-12c and 11-13f).
4. Ball valve leaking or will not shut off.	<ul style="list-style-type: none"> b. Intermittent magneto coil failure. Worn or damaged parts. 	<ul style="list-style-type: none"> b. Replace magneto coil (11-12d). Check and replace damaged parts (11-13g).
5. Couplers leaking or will not engage or disengage.	<ul style="list-style-type: none"> Worn or damaged parts. 	<ul style="list-style-type: none"> Check and replace damaged parts (11-18g).

b. Starter Fan Housing.

(1) *Removal (fig. 11-15).*

(a) Using a thin-walled 5/16-inch socket wrench or a large screwdriver, remove four housing screws (1 and 2).

(b) Lift the starter fan housing and attached parts (3 through 14) out far enough to clear the end tabs of the left and right legs (2 and 5, fig. 11-22). Continue to lift the starter fan housing out far enough to permit disconnecting the ignition switch electrical lead (11, fig. 11-15) at the ignition coil (50). Pull the lead straight off the terminal.

(c) Remove starter fan housing assembly from pump engine.

(2) *Installation.*

(a) Position the starter fan housing assembly (3) with attached parts close enough to the engine so that the ignition switch lead may be

connected to the ignition coil (50). Slide the quick-disconnect terminal (10) straight onto the coil (50) tab.

(b) Hold the starter fan housing assembly in place with one hand. Pull the starter handle

(5) out a short distance with the other hand until the starter fingers engage properly and the fan housing seats against the engine.

CAUTION

Starter fan housing must seat all around to avoid breaking of housing or starter fingers when screws are installed and tightened.

(c) Install and tighten the four screws (1 and 2). Note that lower two screws also secure tabs of right and left legs (5 and 2, fig. 11-22) to fan housing. Note also that the one shorter screw (5/8-in. long) is to be installed in the upper centrally located screw hole.

1. Screw, hex hd,
12-24 x 5/8
2. Screw, hex hd, 12-24 x
1-11/16 in. (3 reqd)
3. Starter fan housing
assembly
4. Rope retaining insert
5. Starter handle
6. Rope bushing
7. Starter post bushing
8. Starter rope
9. Quick-disconnect
terminal
10. Quick-disconnect
terminal
11. Electrical lead
12. Nut, hex, 15/32-32
13. Plate
14. Toggle switch
15. Inner spring shield
16. Recoil spring
17. Outer spring shield
18. Spring lock bushing
19. Spring lock
20. Starter pulley and cup
assembly
21. Screw. hex hd,
10-32 x M in.
22. Washer, flat. No. 10
23. Nut, hex, 5/16-24
24. Washer, lock, 5/16 in.
25. Washer, flat, 5/16 in.
26. Shouldered stud
(2 reqd)
27. Starter finger (2 reqd)
28. Washer, flat (2 reqd)
29. Torsion spring (2 reqd)
30. Magneto rotor
31. Breaker box cover
32. Breaker box cover gasket
33. Breaker box cover spring
34. Assembled washer and
screw
35. Nut, hex, No. 6-312
36. Washer, lock, No. 6
37. Terminal block
38. Terminal stud
39. Hairpin clip
40. Washer (1 or 2 as reqd)
41. Breaker arm group
42. Fixed contact
43. Shielded ignition cable
(HI-tension lead)
44. Captive screw
45. Condenser clamp
46. Condenser
47. Felt cam wiper
48. Coil ground screw
49. Coil wedge
50. Ignition coil
51. Screw, hex hd, 12-24 x 5/8
in. (3 reqd)
52. Stator plate
53. Felt seal
54. Gasket

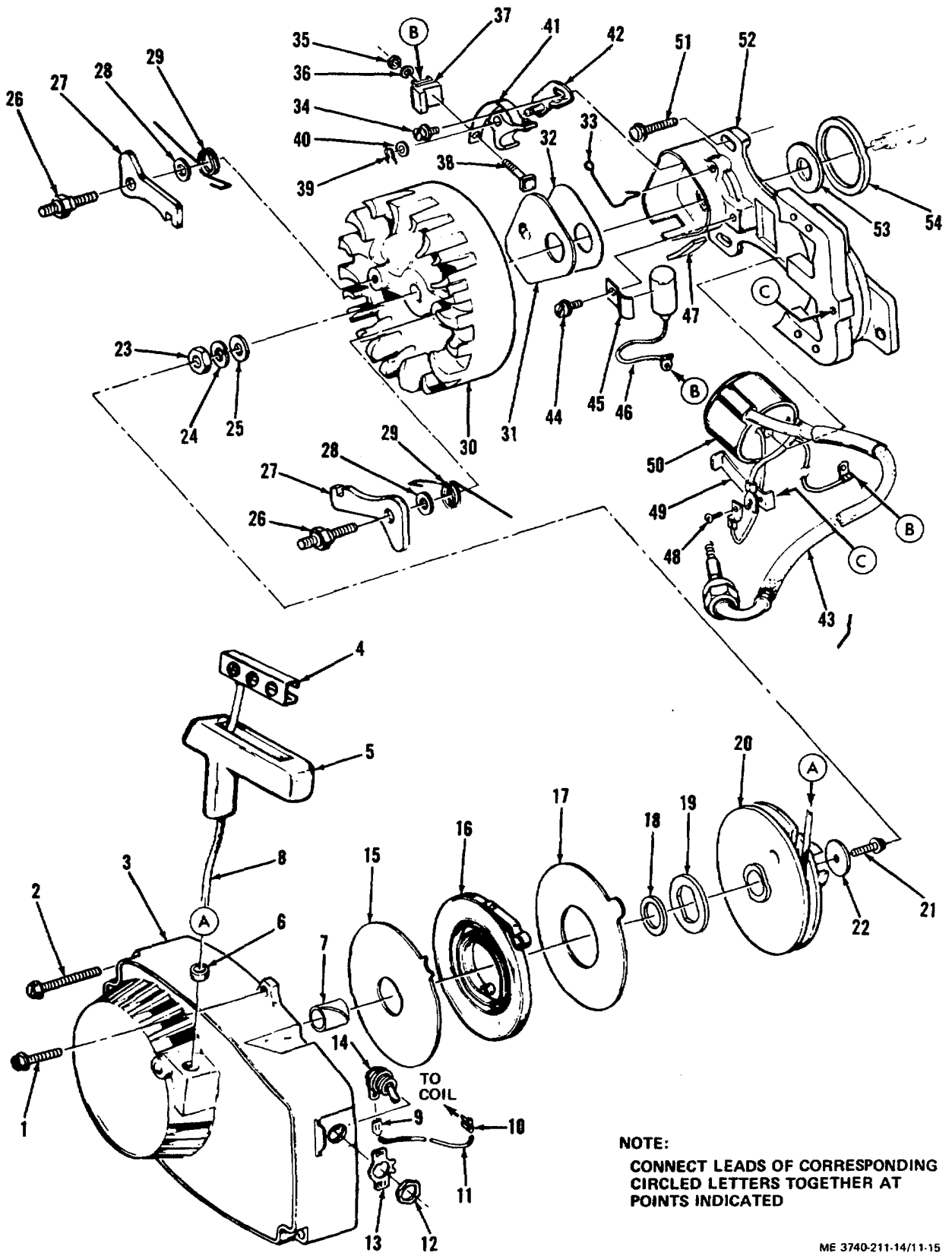

ME 3740-211-14/11-15

Figure 11-15. Starter fan housing and ignition parts - exploded view.

c. Pump.

(1) Removal.

(a) Remove starter fan housing assembly (3, fig. 11-15) as described in step b(l), preceding.

(b) Remove four screws (34 and 35, fig. 11-22) and lock washers (36) holding pump to the vibration mounts (32) on the pump base (31).

(c) Disconnect muffler bracket (22) from pump housing (29) by removing two screws (24) and lock washers (23).

(d) Remove four screws (26) securing pump housing (29) to impeller housing (12). Tap pump housing carefully with a soft mallet to break it loose from the impeller housing. Remove pump housing, two large gaskets (18), one small gasket (25), and the wear plate (19) from impeller housing.

(e) Connect the fabricated rotor locking tool (fig. 11-8) to the magneto rotor as shown in figure 11-16. Use two nuts on shouldered studs

(26, fig. 11-15) to secure tool to rotor.

(f) Use the rotor locking tool to prevent the crankshaft from turning. If the impeller (17, fig. 11-22) is stuck and cannot be turned loose, tap it with a light weight plastic or leather mallet to break it loose, then spin impeller off the shaft.

(g) Remove impeller, seal assembly (16), and shims (15) from end of crankshaft.

Note:

Determine the number and thickness of shims (15) re-moved as an aid to reassembly.

(h) Remove four screws (14) and sealing washers (13) securing impeller housing (12) to bearing housing (7). Remove impeller housing.

(i) Remove slinger (11) from crankshaft.

(j) Remove five screws (10) securing bearing housing (7) to crankcase (22, fig. 11-20). Remove bearing housing (7, fig. 11-22), which carries seal (9) and needle bearing (8). Remove gasket (6). Refer to paragraph 11-31f for instructions for removal of bearing and seal from bearing housing.

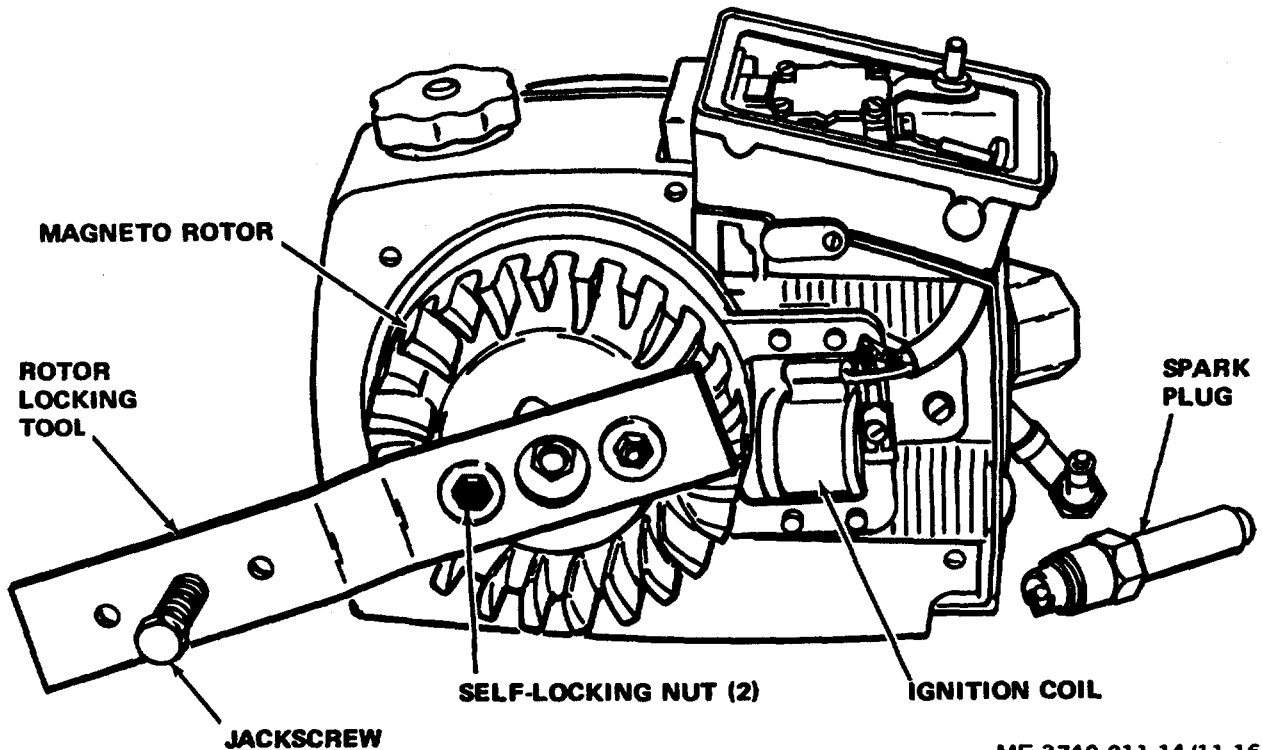

ME 3740-211-14/11-16

Figure 11-16. Using rotor locking tool to hold shaft.

(2) *Installation.*

Note:

When reassembling pump, use all new seals and gaskets.

(a) If engine parts are to be disassembled, do not reassemble pump to engine until engine is completely reassembled.

(b) If needle bearing (8, fig. 11-22) and seal (9) were removed from bearing housing (7), insert new bearing and seal as instructed in paragraph 11-13, step f(3).

(c) Make sure needle thrust bearing (27, fig. 11-20) and thrust bearing race (26) are in place on crankshaft (29). Place fabricated seal assembling sleeve (fig. 11-13) over end of crank-shaft. Lubricate seal assembling sleeve, seal (9, fig. 11-22) and needle bearing (8)., Place crank-case gasket (6) in place, and assemble bearing housing to crankshaft and crankcase (22, fig. 11-20).

CAUTION

Be sure screws used to secure bearing housing to crankcase are 9/16-inch long (not 1/2 or 5/8-inch long). Screw length is critical.

(d) Using new screws (10, fig. 11-22), clean screw threads and apply Loctite to threads before installing screws. Tighten the screws alternately, and remove seal assembling sleeve from crankshaft.

(e) Attach impeller housing (12) to bearing housing (7) using four new sealing washers (13) and screws (14).

(f) Install shims (15) as necessary to provide minimum clearance between impeller (17) and wear plate (19) without causing impeller (17) to rub against wear plate.

(g) Install new seal assembly (16), and then install impeller (17). While installing impeller, hold magneto rotor of engine (30, fig. 11-15) with rotor locking tool (fig. 11-8) as shown in figure 11-16.

(h) Carefully place one new gasket (18, fig. 11-22) into sealing groove of impeller housing (12). Carefully place new gaskets (18 and 25) into sealing grooves in pump housing (29). Secure impeller housing, wear plate (19), and pump housing together with four screws (26).

(i) Secure muffler bracket (22) to pump housing (29) with two lockwashers (23) and screws (24).

(j) Secure engine and pump to vibration mounts (32) on pump base (31). Place a snubbing washer (33) between each engine and pump foot and the vibration mounts. Secure with screws (34 and 35).

(k) Remove the fabricated rotor locking tool from the magneto rotor (30, fig. 11-15).

(l) Replace starter fan housing assembly (3) as described in step b(2), preceding.

d. Ignition Parts.

(1) *Removal.*

(a) Remove the starter fan housing assembly (3, fig. 11-15) as described in step b(1), preceding.

(b) Connect the fabricated rotor locking tool (fig. 11-8) to the magneto rotor in the manner shown in figure 11-16. Use two nuts to secure tool to shouldered studs in rotor.

(c) With rotor blocked, move starter fingers (27, fig. 11-15) aside. Use a 1/2-inch socket wrench through the hole in the rotor locking tool to loosen the rotor nut (23). Remove rotor nut (23), lockwasher (24), and flat washer (25). Screw the rotor nut (23) part way back onto the end of the crankshaft to protect the thread during removal of the rotor. Remove and reposition the rotor locking tool so the jackscrew of the tool is centered over the shaft and lock nut as shown in figure 11-17. Turn the jackscrew down until rotor pops free of crankshaft taper. Remove all tools, fastenings, and rotor.

(d) Disconnect the high-tension lead (43, fig. 11-15) from the spark plug (41, fig. 11-20). Remove the spark plug and gasket (42) from cylinder (43).

(e) Remove three screws (51, fig. 11-15) which hold the stator Plate (52) to the crankcase and cylinder (22 and 43, fig. 11-20).

(f) Remove the complete coil, stator plate, and attached parts. Remove the felt seal (53, fig. 11-15) and gasket (54) from between the stator plate and the crankcase. Do not lose the rotor key which should be in the slot in the crankshaft.

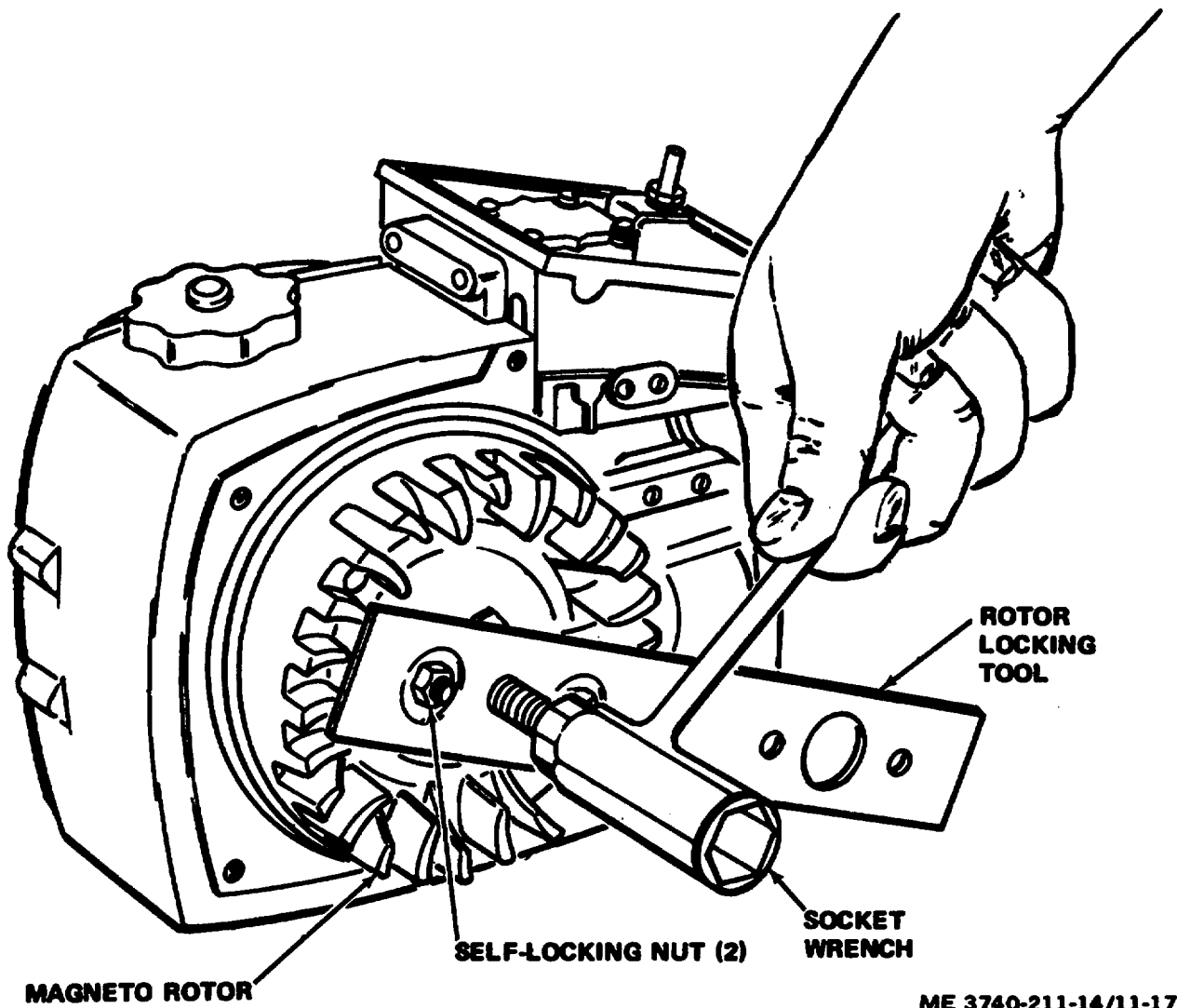

ME 3740-211-14/11-17

Figure 11-17. Removal of magnets rotor.

(2) *Installation.*

(a) Position gasket (54, fig. 11-15) against crankcase (22, fig. 11-20), and felt seal (53, fig. 11-15) on crankshaft.

(b) Secure stator plate (52) to cylinder (43, fig. 11-20) and crankcase with three screws (51, fig. 11-15). Before tightening fully, rotate the stator plate clockwise as far as possible to eliminate any play.

(c) Place gasket (42, fig. 11-20) on spark plug (41). Install spark plug in cylinder (43), and attach high-tension lead (43, fig. 11-15).

(d) Make sure the Woodruff key is installed in the crankcase keyway. Line up the keyway in the magneto rotor (30) with the key and start the rotor onto the shaft. Push the rotor as far as possible by hand, so as to engage the tap-

ered end of the shaft.

(e) Install the flat washer (25), lock washer (24), and nut (23) on the crankshaft.

(f) Secure the fabricated rotor locking tool to the magneto rotor as shown in figure 11-16. Tighten the nut (23, fig. 11-15), to secure magneto rotor (30), with a 1/2-inch socket wrench.

(g) Remove rotor locking tool.

(h) Install starter fan housing assembly

(3) as described in step b (2), preceding.

e. Carburetor Chamber Group.

(1) *Removal.*

(a) Turn captive nut (1, fig. 11-19) counterclockwise and remove the air cleaner element cover (2), air cleaner element (3), and the mounting stud gasket (6).

(b) Remove one cotter pin (13) and un-

hook the choke rod (14) from the carburetor choke shaft and lever (24, fig. 11-21). Pull choke rod out of carburetor chamber (38, fig. 11-19) far enough to clear carburetor, but do not remove completely.

(c) Remove cotter pin (13) from governor link (20) and disengage governor link from carburetor throttle shaft and lever (33, fig. 1-21).

(d) Disconnect governor spring (15, fig. 11-19) from throttle shaft and lever (33, fig. 11-21). Do not remove throttle rod clamp (29, fig. 11-19) from carburetor chamber (38).

(e) Remove two screws (7) and lockwashers (8) which hold the cover mounting bracket (9) and carburetor assembly (32) to the carburetor chamber (38). Remove cover mounting bracket.

(f) Angle or tilt the carburetor from side to side as necessary to remove it. Disconnect the fuel line from the fuel pump inlet fitting on the carburetor by working it off. With a twisting motion, lift the carburetor up on the fuel intake side and lift it out. Remove the carburetor spacer (31) and two gaskets (30).

(g) Remove the fuel line and rubber grommet (33) from carburetor chamber.

(h) Remove five screws (37), four inside carburetor chamber and one outside at the bottom of the chamber. While lifting the carburetor chamber off the engine, free the high-tension lead (43, fig. 11-15) from the clip in the underside of the carburetor chamber.

(2) *Installation.*

(a) Position the carburetor chamber (38, fig. 11-19) on the engine. Push high-tension lead (43, fig. 11-15) into retaining clip located on the underside of the carburetor chamber.

(b) Install rubber grommet (33, fig. 11-19) into carburetor chamber (38), and start fuel line through grommet and into carburetor chamber.

(c) Using five screws (37), secure chamber to engine with four screws, and to fuel tank (at bottom) with the remaining screw.

(d) Angling the carburetor (32) as necessary to place it in position with the adjustment needles fitted through the "LO-HI" grommet (36), push the fuel line onto the carburetor inlet.

(e) Assemble one carburetor gasket (30), carburetor spacer (31), another carburetor gasket (30), the carburetor (32), and the cover mounting bracket (9) to the carburetor chamber. Use two lockwashers (8), and two screws (7) to fasten components. Do not tighten securely at this time.

(f) Install end of governor link (20) into

throttle shaft and lever (33, fig. 11-21). Place through hole nearest unflanged end of throttle lever. Secure with cotter pin (13, fig. 11-19).

(g) Hook end of choke rod (14) to the end hole on the carburetor choke shaft and lever (24, fig. 11-21). Secure with cotter pin (13, fig. 11-19).

Note:

Be sure that choke has been assembled in such a manner that nothing interferes with its operation.

(h) Check alignment of the carburetor, gaskets, and spacer. Tighten the screws (7) to secure carburetor to carburetor chamber.

(i) Install mounting stud gasket (6) over cover mounting bracket (9). Install air cleaner element (3) and air cleaner element cover (2). Secure with captive nut (1).

11-13. **Special Repair Instructions**

a. *Repair of Starter Fan Housing.*

(1) *Disassembly.*

(a) Refer to 11-12, step b (1) for instructions on removing starter fan housing assembly (3, fig. 11-15) from engine.

(b) Place starter fan housing on a bench. Pull the starter rope (8) out to the end. Hold the starter pulley and cup assembly (20) so it cannot rewind, then pry the rope knot from the pulley. Let the pulley rewind slowly to relieve excess tension.

WARNING

The recoil spring (16) is still coiled under tension inside starter fan housing. Use care to protect the hands and face at this point of disassembly because the spring can inflict injury if it flies loose.

(c) Hold the starter pulley and use a 5/32-inch Allen wrench to remove screw (21), and retaining washer (22).

(d) Peer through the knot hole in the pulley while rotating pulley clockwise until you see that the inner loop of the recoil spring (16) is disengaged from the notch in the pulley hub. Carefully lift the pulley straight off without disturbing the spring. Remove spring lock bushing (18), spring lock (19), and starter post bushing (7).

(e) To remove the recoil spring, hold the fan housing, open and down, over a flat work surface. Slap the starter fan housing squarely and sharply down on the work surface to dislodge the recoil spring without its uncoiling.

(f) If starter rope (8) is to be replaced, pry rope retaining insert (4) out of starter handle (5). Cut rope near the insert, and remove the remaining knot end from the insert.

Note:

Do not remove starter rope (8) or rope bushing (6) from starter fan housing (3) unless necessary for replacement.

(g) Remove ground electrical lead (11) with terminals from tab on toggle switch (14). Unscrew nut (12) and remove toggle switch (14) and ON-OFF plate (13).

(2) *Cleaning, inspection, and repair.*

CAUTION

Use solvent in a well-ventilated area. Avoid breathing of fumes and excessive contact with skin. Keep solvent away from open flame. Wash hands before smoking or eating.

(a) Clean all nonelectrical parts with cleaning solvent, Federal Specification P-D-680, or equivalent. Dry parts thoroughly. Apply a film of light oil to all exposed ferrous metal parts as a corrosion preventive.

(b) Inspect all threaded parts for crossed or otherwise damaged threads.

(c) Inspect bearing surfaces and bushings for condition.

(d) Inspect starter rope for worn or frayed condition. Replace if condition is doubtful.

(3) *Assembly (fig. 11-15).*

(a) If rope bushing (6) was removed from starter fan housing (3), insert new bushing.

(b) Lay starter fan housing down so the spring retainer pin is at the 10 o'clock position. Position recoil spring (16) so the outer loop is over the pin and pointing to your left. Push recoil spring down into fan housing.

(c) Place starter post bushing (7) and spring lock bushing (18) over starter post in fan housing.

(d) Place spring lock (19) over end of starter cup shaft on pulley (20), with tang of spring lock facing in counterclockwise direction when looking at pulley from side with rope knot hole (fig. 11-15).

(e) Slide pulley assembly onto starter post bushing (7). Turn pulley clockwise until it engages the recoil spring. Secure pulley on the starter post in the starter fan housing with washer (22) and cap screw (21) using a 5/32-inch Allen wrench.

(f) If a new starter rope is used, thread rope through the hole in starter fan housing. Insert one end of starter rope through starter handle (5), and rope retaining insert (4). Tie a knot in the end of the rope, and harden the knot with liquid cement or by heating. Pull knot tight against inner edge of rope retaining insert, and fit insert into starter handle. Tie and harden a knot in the other end of the rope.

(g) Preload the starter with eight clockwise turns of the pulley. While holding pulley under eight turns tension, slide rope into the pulley

key slot so the knot engages in the key hole. Then let pulley rewind. It will have two turns pretension left when starter handle is drawn up to fan housing.

(h) If ON-OFF plate (13) was removed, install it at ignition switch opening in starter fan housing (3). Install ignition toggle switch (14) and secure with attaching nut (12). Secure one terminal (9) of electrical lead (11) to switch tab.

CAUTION

Starter fan housing must seat all around to avoid breaking housing or starter fingers when screws are installed and tightened. Use only the proper length screws.

(i) Refer to paragraph 11-12, step b(2) for instructions for installing starter fan housing assembly.

b. Repair of Ignition Parts.

(1) *Disassembly (fig. 11-15.)*

(a) Remove ignition parts from engine as instructed in paragraph 11-12, step d(l).

(b) If necessary for parts replacement, unscrew two shouldered studs (26), and remove starter fingers (27), flat washers (28), and torsion springs (29) from magneto roto (30).

Note:

Carefully note position of starter fingers and springs as an aid to reassembly.

(c) Remove breaker box cover (31), cover gasket (32), and cover spring (33).

(d) Remove nut (35), and washer (36) from end of terminal stud (38). Remove black (primary) lead of ignition coil (50) and con-denser (46) lead from terminal stud.

(e) Remove assembled washer and screw (34). Pull entire point set (37 through 42) from breaker box on stator plate (52).

(f) Remove terminal stud (38) and terminal block (37) from spring of breaker arm group (41).

(g) Remove hairpin clip (39) and point washer (40), and separate fixed contact (42) from breaker arm group (41).

(h) Remove captive screw (44), condenser clamp (45), and condenser (46) from stator plate (52).

(i) Remove coil ground screw (48) and ground (white) lead of ignition coil (50) from stator plate (52). Slide ignition coil (50) and coil wedge (49) from armature of stator plate (52).

(j) If necessary for replacement, unscrew high-tension lead (43) from ignition coil.

(k) Remove felt seal (53) from side wall of breaker box portion of stator plate (52).

(2) *Cleaning, inspection, and repair.*

CAUTION

Use solvent in a well-ventilated area. Avoid breathing of fumes and excessive contact with skin. Keep solvent away from open flame. Wash hands before smoking or eating.

(a) Clean all nonelectrical parts with cleaning solvent, Federal Specification P-D-680, or equivalent. Dry parts thoroughly. Apply a film of light oil to all exposed ferrous metal parts (except magneto, points, and electrical contacts) as a corrosion preventive.

(b) Discard breaker point set (39 through 42), condenser (46), and felt seal (53).

(c) Inspect all threaded parts for crossed or otherwise damaged threads.

(d) Inspect high-tension lead (43) and ignition coil (50) for damaged leads, cracked insulation, or other damage. Replace if damaged.

(e) Inspect magneto rotor (30) for cracks or other visible damage. Be sure the rotor keyway and the rotor taper show no wear or damage which could result in a loose or off-center assembly. The rotor must be in perfect shape with no cracks or broken fins.

(f) Inspect starter fingers (27) and torsion springs (29). Worn or broken starter fingers or bent springs should be replaced.

(3) Assembly.

(a) Install a new prelubricated felt seal (53) in the wiper on side wall of breaker box on stator plate (52).

(b) If high-tension lead (43) was removed from ignition coil (50), screw end of high-tension lead into ignition coil.

(c) Slide coil wedge (49) into center of ignition coil (50). Slide ignition coil onto armature of stator plate (52) until tang of coil wedge engages end of armature. Secure coil wedge and coil ground lead (white) to armature with screw (48).

(d) Attach new condenser (46) to stator plate (52) with condenser clamp (45). Secure with captive screw (44).

(e) Insert post of new fixed contact (42) through new breaker arm group (41), and secure with washer (40) and hairpin clip (39).

CAUTION

When installing the breaker arm group, do not bend the tension spring more than necessary to fit the points in place. A change in tension may cause a bouncing motion, which in turn causes improper contact.

(f) Place entire point set (37 through 42) into breaker box of stator plate (52). Start the terminal block (37) into position in the slot of the stator plate breaker box and at the same time en-gage the breaker arm pivot pin in the hole in the floor of the box. Secure the fixed contact (42) to the breaker box with the assembled washer and screw (34). Hook the primary (black) lead of the ignition coil (50) through the lead guide in the floor of the breaker box. Wrap the condenser lead twice around the coil primary lead. Insert terminal stud (38) through spring of breaker arm group (41) and through terminal block (37). Put primary lead on terminal stud, and slip the condenser (46) lead over the primary coil lead. Push terminal block (37) all the way down in the slot and secure with the terminal washer (36) and nut (35).

(g) Set contact point gap at this point.

Note:

The proper contact point setting is 0.015 inch. For emergency repairs, the cover of a paper match book, which is usually about 0.015-inch (1/64-inch) thick may be used as a feeler gage; however, for setting the gap accurately, without fear of scratching the points, a plastic feeler gage should be used.

(h) Rotate the engine crankshaft in a counterclockwise manner until the breaking edge of the actuating cam is 1/8 inch beyond the breaker arm cam follower. This is the highest point of the cam. Loosen the assembled washer and screw (34), and move the fixed contact (42) as necessary to set the gap. Check by moving the feeler gage between the points. When the gap is 0.015 inch, you should feel a slight, steady, smooth friction as you move the gage. After tightening the assembled washer and screw (34), check the gap again to see that it is still 0.015 inch. Readjust if necessary.

(i) Place cover gasket (32) and breaker box cover (31) in place, and secure with cover spring (33).

(j) Install the torsion springs (29), flat washers (28), and starter fingers (27) to magneto rotor (30) with shouldered studs (26). Be sure that the torsion springs are so located between two vanes of the rotor that the springs will be parallel to the flat edges of the starter fingers when the fingers are touching the rotor nut (23) (fig. 11-18). The fingers should have no more spring tension than is necessary to hold them against the rotor nut.

(k) Complete assembly of ignition parts to engine as instructed in paragraph 11-12, step d(2).

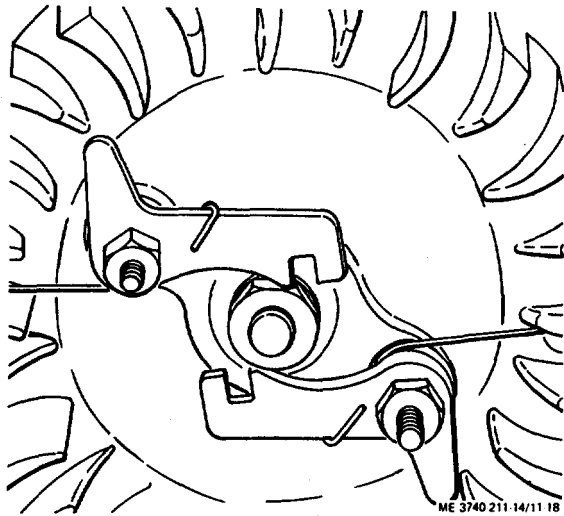

Figure 11-18. Starter finger and torsion spring position.

c. *Repair of Carburetor Chamber.*

Note:

This paragraph contains complete repair instructions for the carburetor chamber, but not for the carburetor assembly. Refer to paragraph 11-13, step e, for carburetor assembly repair instructions.

(1) *Disassembly (fig. 11-19).*

(a) Remove carburetor chamber group from engine as instructed in paragraph 11-12, step e(1).

(b) If necessary for replacement, remove instruction plate (5), retaining ring (4), and captive nut (1) from air cleaner element cover (2).

(c) Remove felt plug (10) from carburetor chamber subassembly (38).

(d) Remove choke button (11) from end of choke rod (14). Remove choke rod and rubber grommet (12) from carburetor chamber.

(e) Remove governor link (20) from air vane governor (19). Remove two screws (18), and air vane governor (19) from beneath carburetor chamber.

(f) Remove and discard two screws (21) securing reed assembly (22 through 24) to carburetor chamber. Remove reed stop (22), reed spring (23), and reed (24).

(g) Remove governor spring (15) from throttle return spring clamp (17). Remove screw (16), and throttle return spring clamp (17).

(h) Remove two throttle rod friction adjust screws (34) and springs (35) from outside of carburetor chamber (38). Remove throttle rod clamp (29) and washers (26).

(i) Remove setscrew (25) from throttle rod collar (27). Slide throttle rod (28) from throttle rod collar, and from carburetor chamber. Remove throttle rod collar from carburetor chamber.

(j) Remove rubber grommet (36) from carburetor chamber.

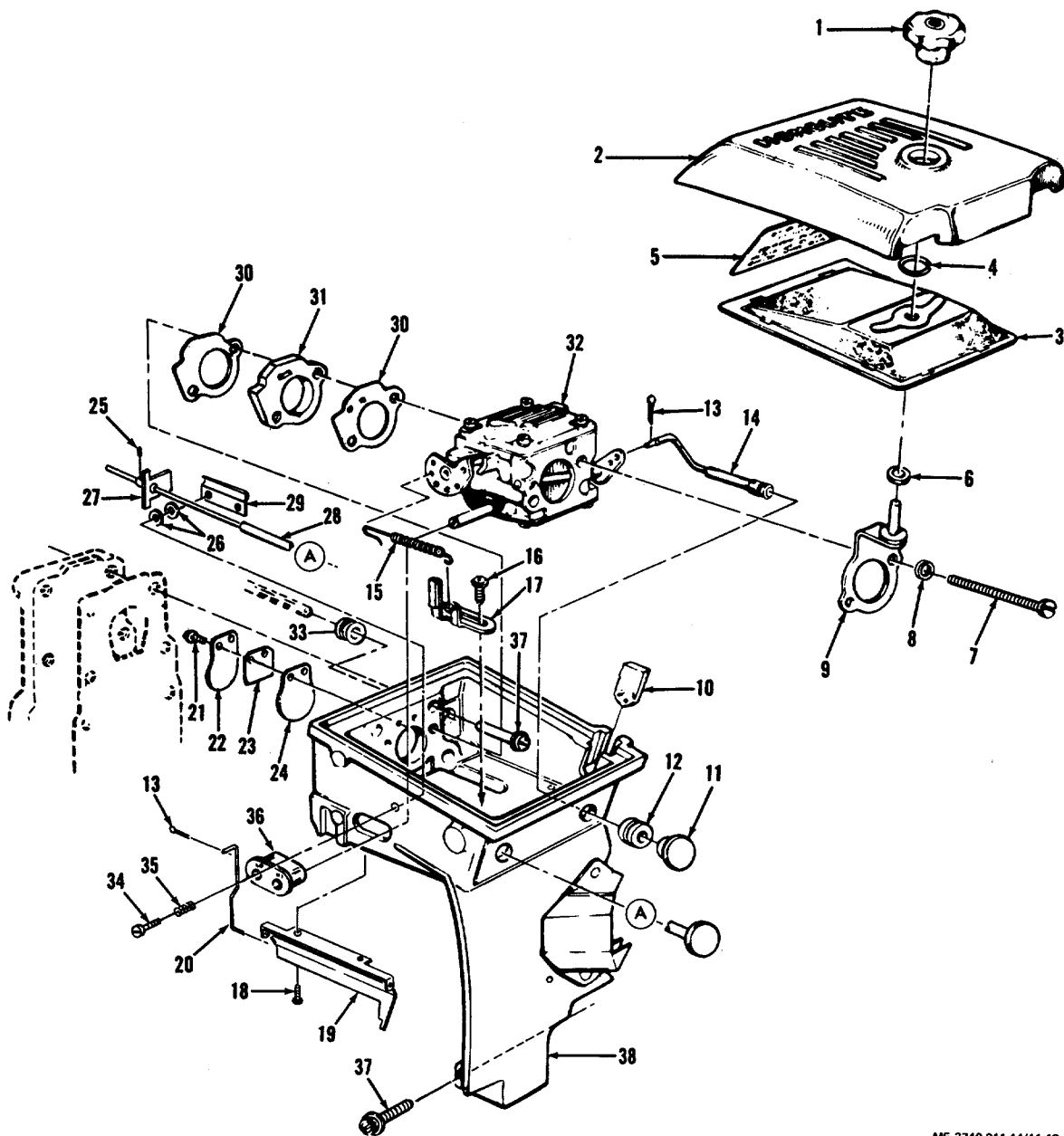

ME 3740-211-14/11-19

- | | | | |
|--|---|---|---|
| 1. Captive nut | 11. Choke button | 21. Screw, pan hd, 4-40 x 3/16 in. (2 reqd) | 31. Carburetor spacer |
| 2. Air cleaner element cover | 12. Rubber grommet | 22. Reed stop | 32. Carburetor assembly |
| 3. Air cleaner element | 13. Cotter pin | 23. Reed spring | 33. Rubber grommet |
| 4. Retaining ring | 14. Choke rod | 24. Reed | 34. Screw, pan hd, 8-32 x 3/8 in. (2 reqd) |
| 5. Instruction plate | 15. Governor spring | 25. Setscrew, 4-40 x 1/8 in. | 35. Spring (2 reqd) |
| 6. Gasket | 16. Screw, pan hd 8 32 x 1/4 in. (2 reqd) | 26. Washer, flat, no. 8 (2 reqd) | 36. Rubber grommet |
| 7. Screw, hex hd. 10-32 x 2 1/4 in. (2 reqd) | 17. Throttle return spring clamp | 27. Throttle rod collar | 37. Screw, hex hd, 12-24 x 7/8 in. (5 reqd) |
| 8. Washer, lock no. 10 (2 reqd) | 18. Screw, pan hd, 4-40 x 3/16 in. (2 reqd) | 28. Throttle rod | 38. Carburetor chamber subassembly |
| 9. Cover mounting bracket | 19. Air vane governor | 29. Throttle rod clamp | |
| 10. Felt plug | 20. Governor link | 30. Carburetor gasket (2 reqd) | |

Figure 11-19. Carburetor chamber - exploded view.

(2) *Inspection and repair (fig. 11-19).*

(a) Inspect all parts for visible damage, and replace those parts which do not meet minimum inspection requirements.

(b) Inspect reed (24) to be sure it is not cracked, warped, or ragged.

(c) Inspect the surface of carburetor chamber (38) on which the reed seats. There must be no gouges or wear indicated.

(d) Inspect all threaded parts for crossed or otherwise damaged threads.

(e) Inspect condition of rubber grommets (12, 33, and 36) and felt plug (10).

(f) Inspect air cleaner element (3) and gasket bonded to air cleaner element. If either gasket or element is damaged, discard and install new air cleaner element.

(g) Inspect condition of fuel line. Replace if it is damaged or considered doubtful.

(3) *Assembly (fig. 11-19).*

(a) Insert grommet (36) into carburetor chamber (38).

(b) Insert throttle rod (28) into carburetor chamber and through throttle rod collar (27). Secure with setscrew (25).

(c) Place springs (35) on two screws (34). Insert screws into holes in side of carburetor chamber. Place a washer (26) over each screw, and attach screws to throttle rod clamp (29). Place throttle rod clamp with holes down, and concave surface adjacent to throttle rod (28). Tighten screws only as required to keep throttle rod from slipping during pump operation.

(d) Place throttle return spring clamp (17) in position. Use the marks left by previous screw heads to locate proper position of clamp. Secure with two screws (16).

(e) Hook short end of governor spring (15) in hole in tab of throttle return spring clamp (17). Hook long end of governor spring (15) in second hole from unflanged end of throttle shaft and lever (33, fig. 11-21).

(f) Install air vance governor (19, fig. 11-19) to bottom of carburetor chamber (38). Secure with screws (18). Slip end of governor link (20) through hole in bottom of carburetor chamber. Fasten governor link (20) to air vance governor (19).

(g) Install reed (24), reed spring (23), and reed stop (22) to carburetor chamber with two screws (21). Be sure the reed components are perfectly centered on the valve face before tightening screws.

(h) Install grommet (12) in carburetor chamber (38). Slide choke rod (14) into carbure-

tor chamber. Screw choke button (11) on choke rod.

(i) If removed, install instruction plate (5) in underside of air cleaner element cover (2). Place captive nut (1) through air cleaner element cover (2) and secure with retaining ring (4).

(j) Install carburetor assembly (32) in carburetor chamber as instructed in paragraph 11-12, step e(2).

d. Repair of Engine (fig. 11-20).

(1) *Disassembly.*

(a) Remove starter fan housing as instructed in paragraph 11-12, step b (1).

(b) Remove muffler as instructed in paragraph 11-8, steps c(1) and c(2).

(c) Remove pump as instructed in paragraph 11-12, step c(1).

(d) Remove ignition assembly as instructed in paragraph 11-12, step d(1).

(e) Remove carburetor chamber group as instructed in paragraph 11-12, step e(1).

(f) Remove two screws (37), and remove manifold (40).

(g) Using a thin walled, 7/16-inch offset wrench (fig. 11-9), remove the two innermost cylinder nuts (39, fig. 11-20) and lock washers (38). Using a 7/16-inch deep socket with a short extension, remove the remaining two cylinder nuts (39) and lockwashers (38).

(h) Grasp the cylinder (43) firmly and lift it straight off the piston and pin (34). Pack rags around the piston to prevent damage.

(i) Remove crankcase gasket (21) from crankcase (22). Do not remove studs (25) from crankcase unless replacement is necessary.

(j) Use a 9/64-inch Allen wrench to loosen socket head screws (32). Discard the screws. Remove both halves of connecting rod (30) and all 28 needle rollers (33).

(k) Using fabricated needle bearing assembly tool (fig. 11-10), press needle bearing (31, fig. 11-20) out of connecting rod (30).

(l) Using a pair of retaining ring pliers, remove retaining ring (35) from piston and pin (34).

CAUTION

Do not press piston pin removal tool too far into piston or the spirol pin will shear off.

(m) Insert fabricated piston pin removal tool (fig. 11-14) past the spirol pin in piston (34, fig. 11-20). Press or tap out piston pin.

(n) Starting from the top of the piston (34), carefully expand piston rings (36) to clear the piston, and remove them.

(o) Slide crankshaft (29) straight out of crankcase (22). Remove thrust bearing race (26) and needle thrust bearing (27) from each end of the crankshaft. Remove rotor key (28).

(p) Using fabricated bearing and seal tool (fig. 11-11), remove needle bearing (24, fig. 11-20) and seal (23) from crankcase (22). Insert the longer shouldered end of the tool from inside the crankcase and press the parts out.

(q) Remove fuel filter cap (8) and fuel cap gasket (9) from fuel and oil tank (6).

(r) Remove three screws (7) and remove fuel oil tank (6) from crankcase (22).

(s) Remove flexible fuel line (19) from fuel line elbow (20), and remove fuel line elbow from fuel and oil tank.

(t) Remove all 16 cover-to-tank screws (18). Remove cover (1) from fuel and oil tank (6).

(u) Remove nut (11), flat washer (12), spring (13), wick washer (14), felt washer (4), gasket (15) and fuel pickup wick (16) from wick stud (17). Remove wick stud from fuel tank cover (1).

(v) Do not remove pipe plug (5), or drain and filler cap (2) and gasket (3) unless necessary for replacement.

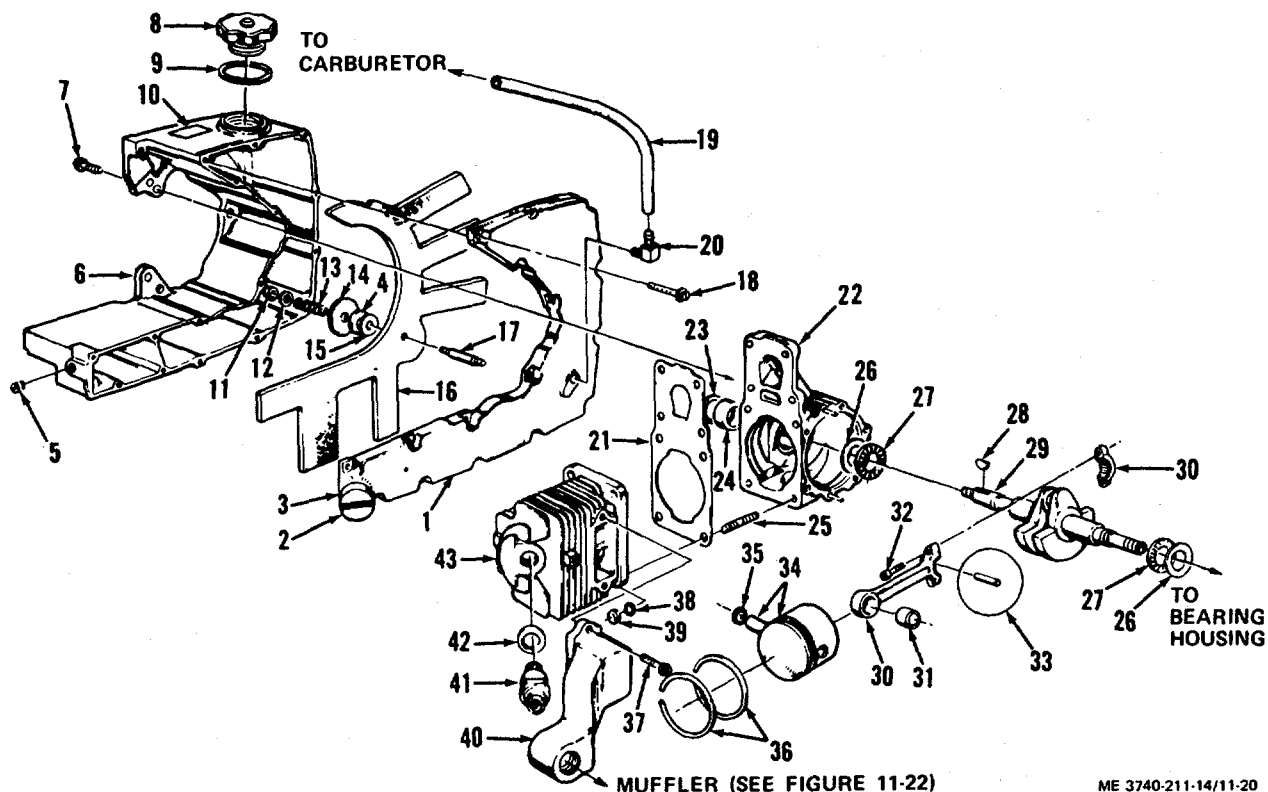

ME 3740-211-14/11-20

- | | | | |
|--|--|---|--|
| 1. Fuel tank cover | 13. Spring | 24. Bearing | 33. Rollers - set of 28 |
| 2. Drain and filler cap | 14. Wick washer | 25. Stud (4 reqd) | 34. Piston and pin |
| 3. Gasket | 15. Gasket | 26. Thrust bearing race
(2 reqd) | 35. Retaining ring |
| 4. Felt Washer | 16. Fuel pickup wick | 27. Needle thrust bearing
(2 reqd) | 36. Piston ring (2 reqd) |
| 5. Pipe plug | 17. Wick stud | 28. Rotor key | 37. Screw, hex hd, 12-24 x
3/4 (2 reqd) |
| 6. Fuel and oil tank | 18. Screw, rd hd, No. 6 x 1/2
(16 reqd) | 29. Crankshaft | 38. Washer, lock, 1/4 (4
reqd) |
| 7. Screw, shoulder, 1/4-20 x
3/4 (3 reqd) | 19. Flexible fuel line | 30. Connecting rod | 39. Nut, 1/4-28 (4 reqd) |
| 8. Fuel filler cap | 20. Fuel line elbow | 31. Bearing | 40. Manifold |
| 9. Gasket | 21. Crankcase gasket | 32. Screw, socket, 8-36 x 1/2
(2 reqd) | 41. Spark plug |
| 10. Decal | 22. Crankcase | | 42. Gasket |
| 11. Nut, lock, 10-32 | 23. Seal | | 43. Cylinder |
| 12. Washer, flat, No. 10 | | | |

Figure 11-20. Engine - exploded view.

(2) *Inspection and repair (fig. 11-20).*

(a) Discard socket head screws (32), 28 needle rollers (33), and retaining ring (35) each time they are removed.

(b) Discard seal (23) whenever it is removed from crankcase (22). Discard fuel pickup wick (16) whenever it is removed from fuel and oil tank (6).

(c) Inspect and clean or replace spark plug (41) as required. Reset gap to 0.035 inch.

(d) Clean and inspect cylinder (43) for worn chrome plating. Replace if more than three of the cooling fins are cracked or broken off or if cylinder walls are badly worn or scored.

(e) Inspect cylinder (43), crankshaft (29), and crankcase (22) for cracks, porous spots, and scored sealing surfaces.

(f) Inspect needle bearings (24, and 31) by trying to separate the needles at one end. If the needles can be separated more than the width of one needle, replace the bearing.

CAUTION

Do not clean varnish-like deposits from piston skirt or side walls of cylinder (43). Use extreme care so as not to scratch polished chrome surfaces.

(g) Scrape heavy deposits from the top of piston (34) and clean by carefully wire-brushing only the dome area.

(h) Using the butt end of a discarded piston ring, carefully clean piston ring grooves in piston (34). Wash the piston in an approved cleaning solvent.

(i) Inspect piston rings (36) for wear. Replace if they are scored, have excessively round wear pattern, or have machining marks worn away.

(3) *Assembly.*

(a) *Assemble fuel and oil tank.*

1. Install wick stud (17) into fuel tank cover (1). Place new fuel pickup wick (16) over stud. Secure with gasket (15), felt washer (4), wick washer, (14), spring (13), flat washer (12), and nut (11).

2. Apply cement (Homelite part number 22788, or equivalent; no known service specification) to the sealing surfaces of the tank and cover.

3. Lay out fingers of fuel pickup wick in the fuel and oil tank while installing the cover. Secure fuel tank cover (1) to fuel and oil tank (6) using 16 screws (18).

4. Install pipe plug (5) and drain and filler cap (2) and gasket (3), if they were re-moved.

5. Screw fuel line elbow (20) into fuel tank cover (1). Slip end of flexible fuel line (19) over fuel line elbow.

Note:

If a new fuel line is being installed, place end of fuel line in boiling water until soft. Then install. Once stretched, the fuel line may be reinstated without further heating.

(b) *Assemble engine.*

1. Using fabricated bearing and seal tool (fig. 11-11), install needle bearing (24, fig. 11-20) in crankcase (22). Use the shorter shouldered end of the tool (from the interior of the crankcase), pressing against the lettered side of the needle bearing only.

2. Using a new seal (23), greased to protect it from damage, place the seal on the long end of fabricated seal assembling plug (fig. 11-12), with the open end of the seal facing the needle bearing (24, fig. 11-20). Install the seal from the outer surface of crankcase.

3. Install thrust bearing (27) and bearing race (26) on each side of the crankshaft (29).

4. Making sure the rotor key (28) is not in place, install fabricated seal assembling sleeve (fig. 11-13) with beveled end out onto the key end of crankshaft. Lubricate the sleeve and end of the crankshaft to prevent damage.

5. Carefully insert crankshaft (29, fig. 11-20) into crankcase (22). Remove seal assembling sleeve and install it on the opposite end of the crankshaft. Lubricate the sleeve and shaft as in step 4, preceding. Install rotor key (28) in key-way of crankshaft (29).

CAUTION

Be sure screws used to secure bearing housing to crankcase are 9/16-inch long (not 1/2-inch or 5/8-inch long). Screw length is critical.

6. Place bearing housing (7, fig. 11-22) in position. Secure with five new screws (10), prepared by cleaning threads and applying a coat of sealant (Loctite screw-lock), to threads. Tighten screws alternately. Remove seal assembling sleeve from crankshaft after assembly.

7. Using fabricated needle bearing assembly tool (fig. 11-10), install needle bearing (31, fig. 11-20) into connecting rod (30). Press bearing only on lettered side.

8. Carefully install piston rings (36) on piston (34). Open ends of piston rings must be adjacent to piston ring locating pin.

Note:

Piston ring retaining pin is permanently installed in piston. It may be seen at top edge of piston, and extends through both piston ring grooves.

9. Insert connecting rod (30) into piston (34). Start blunt end of piston pin through

piston from same side as piston ring locating pin (ref step 8, preceding). Insert a rod of approximately 3/16-inch diameter into the open end of the piston pin, and press or tap pin into position flush against the spirol pin (located in piston pin bore in piston).

10. Using a pair of retaining ring pliers, install a new retaining ring (35) into groove in piston. Be sure the square edge of the ring faces outward. Rotate the ring to be sure it is installed properly. Align the open end of the ring parallel with the connecting rod (either up or down).

CAUTION

When installed in the engine, piston must be oriented so that open end of piston rings, and open end of piston pin are on side toward starter assembly. Match marks on mating flanges of upper and lower connecting rod halves must be in alignment.

11. Using bearing grease or beeswax to lay out the rollers (33) lay out two strips, each of 14 new rollers. Stick on strip into each of the connecting rod (30) halves. Determine the direction in which the piston (34) must be placed in the engine (open ends of piston rings and open end of piston pin toward starter assembly side of the engine). Align the match marks on the connecting rod (30) halves.

12. Place the lower half of the connecting rod into position in the crankcase under the crankshaft (29) journal. Hold these parts in place with a strip of metal or wire bent beneath the lower half of the connecting rod. Lower the upper half of the connecting rod into position in crank-case (22). Use two new socket head screws (32) to fasten the halves of the connecting rod together. Before securing the screws completely, be sure none of the rollers are out of place. Tighten screws (32) with a 9/64-inch Allen wrench to 60 inch-pounds torque. Rotate crankshaft to see that bearing works smoothly.

13. Place the crankcase gasket (21) on the crankcase studs. Be sure the holes in the gasket are aligned with the mounting holes in the fuel intake section of the casting.

14. If a piston ring compressor is not available, make one out of a tin can or strip of metal bent to the outside diameter of the piston (34). Squirt oil into the cylinder (43) and oil the piston. Compress the piston rings with the piston ring compressor, and push the cylinder straight down onto the piston. When both rings have started into the cylinder, see that the cylinder exhaust ports are on the pump side of the crank-

case. Remove piston ring compressor, and secure cylinder (43) and gasket (21) to crankcase with four lockwashers (38) and cylinder nuts (39). Tighten nuts alternately with the fabricated off-set wrench (fig. 11-9).

e. *Repair of Carburetor (fig. 11-21).*

(1) *Disassembly.*

(a) Remove carburetor from engine as instructed in paragraph 11-12, step e(1).

(b) Remove four screws (1) and lockwashers (2) from the pump cover (3). Lift the fuel pump cover, gasket (4), and pump diaphragm (5) from the carburetor body (35). Re-move the inlet screen (6) by picking it out carefully with a sharp pointed instrument.

(c) Remove four screws (7) and lockwashers (8) from the diaphragm cover (9), and lift off the diaphragm cover, the diaphragm (10), and the diaphragm gasket (11).

(d) Remove the fulcrum pin retaining screw (12), the fulcrum pin (13), inlet valve control lever (14), control lever comparison spring (15), and the inlet needle (16).

Note:

During servicing be very careful not to stretch the control lever compression spring. It is made to a predetermined length by the manufacturer.

(e) If necessary, remove expansion plug (17) (ref step (2) (c), following). Remove plug (18) with screen (19) and retaining ring (20) from body (35).

(f) Remove screw (28) and lockwasher (29) from throttle shaft and lever (33). Remove throttle shutter (31) from throttle shaft and lever (33).

(g) Remove screw (28) and lockwasher (29) from throttle shaft clip (30). Remove throttle shaft clip and spring pin (32) from throttle shaft and lever (33), and pull throttle shaft from the body (35).

(h) Close the choke and tap the large center section of the choke shutter (25) just above the top of the shaft to bend it back in line with the remainder of the shutter. Open the choke, and pull the shutter out of the slot in the choke shaft and lever (24) with pliers. While pulling the choke shaft out, hold a hand over the rear of the body (35) to catch the choke friction ball bearing (26) and spring (27). These parts are installed inside of barrel opposite choke lever and are ejected when the shaft is removed.

(i) Remove the main and idle adjustment screws (21 and 22), springs (23), and connector elbow (34) from body (35).

- | | | | |
|---|--|---|----------------------------------|
| 1. Screw, fil hd, 6-32 x ½ in. (4 reqd) | 9. Diaphragm cover | 19. Screen | 29. Washer, lock, No. 4 (2 reqd) |
| 2. Washer, lock, No. 6 (4 reqd) | 10. Diaphragm | 20. Retaining ring | 30. Throttle shaft clip |
| 3. Pump cover | 11. Diaphragm gasket | 21. Main adjustment screw | 31. Throttle shutter |
| 4. Fuel pump gasket | 12. Screw, thread cutting, 4-40 x 5/16 in. | 22. Idle adjustment screw | 32. Spring pin |
| 5. Fuel pump diaphragm | 13. Fulcrum pin | 23. Compression spring (2 reqd) | 33. Throttle shaft and lever |
| 6. Screen | 14. Inlet valve control lever | 24. Choke shaft and lever | 34. Connector elbow |
| 7. Screw, round hd, 4-40 x 1/4 in. (4 reqd) | 15. Compression spring | 25. Choke shutter | 35. Body |
| 8. Washer, lock, No. 4 (4 reqd) | 16. Inlet needle | 26. Ball bearing | |
| | 17. Expansion plug | 27. Compression spring | |
| | 18. Plug | 28. Screw, round hd, 4-40 x 3/16 in. (2 reqd) | |

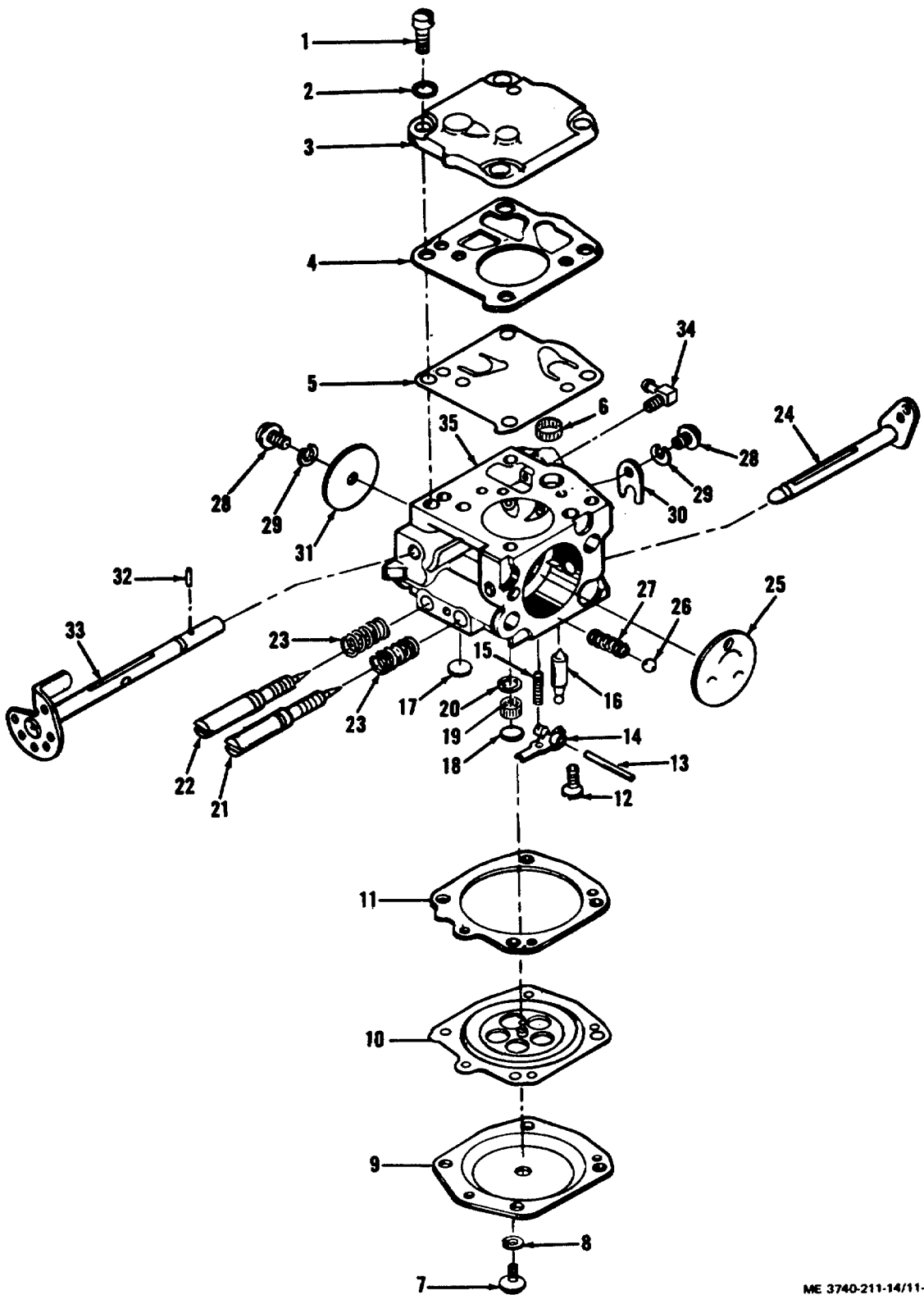

ME 3740-211-14/11-21

Figure 11-21. Carburetor assembly - exploded view.

(2) *Cleaning, inspection, and repair.*

(a) Soak the carburetor body (35) and all parts to be retained in the rebuilt assembly, except diaphragms and gaskets, in carburetor cleaning solvent. Blow all passages clean with an air hose. Clean the small hole running from the spring cavity within the carburetor body to the venturi with a 0.010-inch diameter wire.

(b) Inspect all parts of the carburetor for serviceability. Make the following specific checks: 1. Inspect fuel pump diaphragm (5) and diaphragm (10) for breaks or punctures. Replace if damaged.

2. Inspect all threaded parts for crossed or otherwise damaged threads.

(c) In extreme cases of clogged channels and discharge ports, it may be necessary to remove expansion plug (17). If required, drill a 1/16-inch hole through the plug just deep enough to break through the plug. Carefully pry out the plug and discard. Clean channels and discharge ports. Install a new plug by placing the plug in well, convex side out. Flatten with a tool slightly larger than the plug.

(3) *Assembly.*

(a) Place spring (23) over main and idle adjustment screws (21 and 22). Install adjustment screws into body (35), in positions shown in figure 11-21.

(b) Insert choke friction spring (27) and ball bearing (26) in spring cavity inside barrel.

Hold these parts in place while sliding the choke shaft and lever (24) into the body (35). Slide choke shutter (25) into slot in choke shaft and lever.

(c) Slide throttle shaft and lever (33) into body (35). Secure with spring pin (32). Place throttle shaft clip (30) over end of throttle shaft and lever and secure with lockwasher (29) and screw (28).

(d) Slide throttle shutter (31) into slot in throttle shaft and lever (33) and secure with lockwasher (29) and screw (28).

(e) Turn body over, and install inlet needle (16) and control lever compressor spring (15) into their respective positions in body (35).

Place inlet valve control lever (14) into position, and slide fulcrum pin (13) through holes in inlet valve control lever and body. Secure components in place with screw (12). Be sure that spring rests in the well of body and is located on the dimple of the control lever.

Note:

The valve control lever is properly set when flush with the floor of the diaphragm chamber.

If diaphragm end of lever is low, pry it up. If lever is high, depress diaphragm end and push on inlet needle for proper adjustment.

(f) Install diaphragm gasket (11), diaphragm (10), and diaphragm cover (9) on bottom of body. Be sure to align parts properly with pins cast in body. Secure with lockwashers (8) and screws (7). Tighten screws evenly.

(g) Insert inlet screen (6) into well in top of body (35).

(h) Install fuel pump diaphragm (5), fuel pump gasket (4), and pump cover (3) on top of body. Be sure to align parts properly with pins cast in body. Secure with lockwashers (2) and screws (1). Tighten screws evenly.

f. Repair of Pump (fig. 11-22).

(1) *Disassembly.*

(a) Remove pump from engine as instructed in paragraph 11-12, step c(1).

(b) Using fabricated bearing and seal tool (fig. 11-11), press both the needle bearing (8, fig. 11-12) and seal (9) from bearing housing (7). Press from outside of bearing housing.

(c) Remove drain and filler caps (27) and gaskets (28) from pump housing (29).

(d) Using a strap wrench to prevent damage to threads, remove inlet fitting (30) from pump housing (29).

(2) *Inspection and repair.*

(a) Inspect all parts for damage and serviceability. Replace any parts considered doubtful.

(b) Check all threaded parts for crossed or otherwise damaged threads.

(c) Check all seals and gaskets for breaks, cracks, elasticity, and shape. Replace any defective parts.

(d) Check condition of needle bearing (8).

Try to separate the needles in the bearing. If needles have flat spots, or can be separated more than the width of one of the needles in the caged assembly, replace the bearing.

(e) Replace seal (9) each time it is removed from bearing housing (7).

(f) Check all castings for evidence of breaks, cracks, porosity, scored sealing surfaces, and for stripped, enlarged, or cross-threaded screw holes. Replace unserviceable castings.

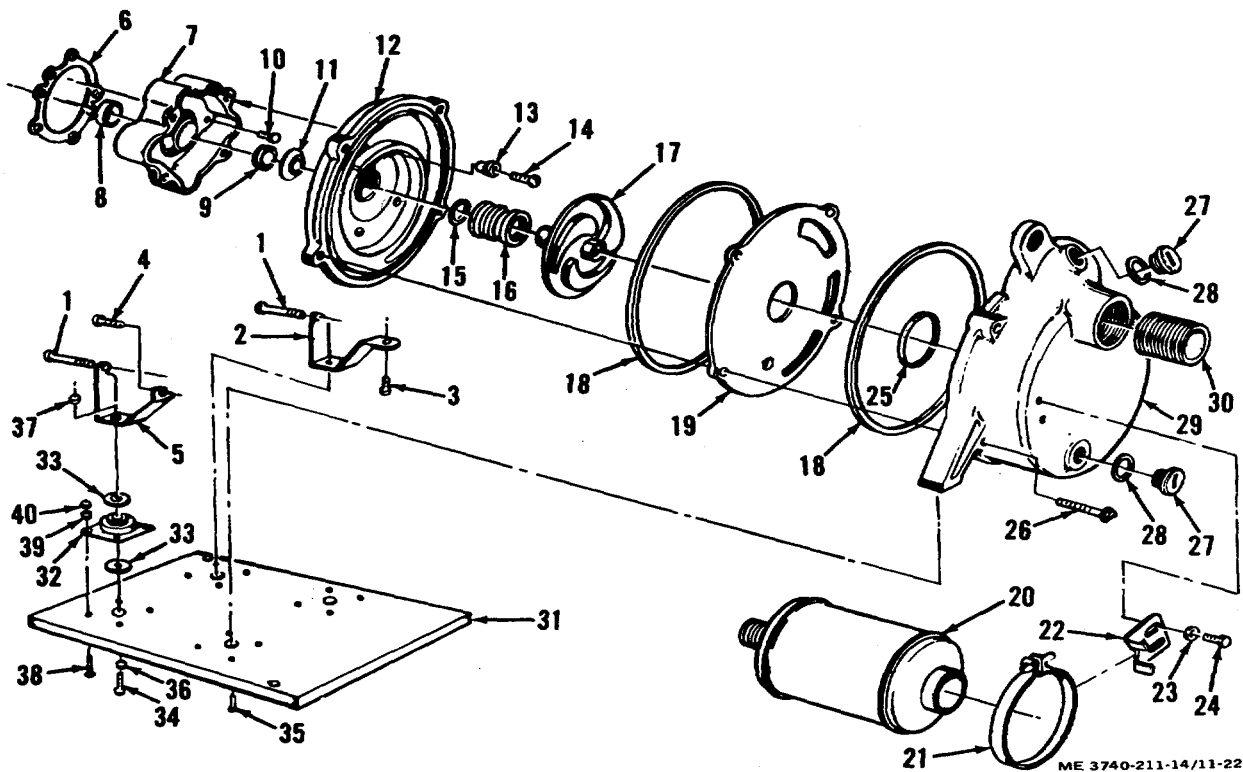

- | | | | |
|--|---|--|--------------------------------------|
| 1. Screw, hex hd, 12-24 x 1-11/16 (2 reqd) | 12. Impeller housing | 23. Lock washer (2 reqd) | 33. Snubbing washer (8 reqd) |
| 2. Left leg | 13. Sealing washer (4 reqd) | 24. Screw, hex hd, 1-20 x 1/2 (2 reqd) | 34. Screw, Y4-20 x 1-24 (2 reqd) |
| 3. Screw, hex hd, 12-24 x 3/8 | 14. Screw, pan hd, 12-24 x 1/2 (4 reqd) | 25. Gasket | 35. Screw, Y4-20 x 1 (2 reqd) |
| 4. Screw, hex hd, 12-24 x 3/7 | 15. Shim (as reqd) | 26. Screw, hex hd, 1/2-20 x 1/2 (4 reqd) | 36. Lock washer, 1Y in. (4 reqd) |
| 5. Right leg | 16. Seal assembly | 27. Drain and filler cap (2 reqd) | 37. Nut, 1/2-20 (2 reqd) |
| 6. Gasket | 17. Impeller | 28. Gasket (2 reqd) | 38. Screw, flat hd, No. 10 (16 reqd) |
| 7. Bearing housing | 18. Gasket, 6-3/8 in. ID (2 reqd) | 29. Pump housing | 39. Lock washer, No. 10 (16 reqd) |
| 8. Needle bearing | 19. Wear plate | 30. Fitting, 1-1/2 in | 40. Nut, hex No. 10 (16 reqd) |
| 9. Seal | 20. Muffer | 31. Pump base | |
| 10. Screw, hex hd, 12-24 x 9/16 (5 reqd) | 21. Muffer strap with screw | 32. Vibration mount (4 reqd) | |
| 11. Slinger | 22. Muffer bracket | | |

Figure 11-22. Pump assembly - exploded view.

(3) Assembly.

(a) Install inlet fitting (30) in pump housing (29). Use Military Specification MILT27730 teflon tape on pipe threads.

(b) Install gaskets (28), and drain and filler caps (27) in pump housing (29).

(c) Using the short shoulder end of fabricated bearing and seal tool (fig. 11-11), press bearing (8, fig. 11-22) into bearing housing (7).

Press against lettered end of bearing only, from outside of bearing housing.

(d) Using a new seal (9), greased to protect it from damage, place the seal on the long

end of fabricated seal assembling plug (fig. 1112), with the open end of the seal facing the needle bearing. Install the seal from the interior of the bearing housing.

(e) Complete installation of pump assembly as instructed in paragraph 11-12, step c(2).

g. Repair of Ball Shutoff Valve.

(1) Disassembly (fig. 11-23).

(a) Remove two nuts (1) and handle (2) from stem (12).

(b) Remove bell washer (3), follower (4), and stem seal (5) from stem (12).

(c) Remove four nuts (6) and four bolts

(7) attaching valve ends (8) from body (14).

(d) Remove two body seals (9) and two seats (10) from body (14).

(e) Remove ball (11) and stem (12) with thrust bearing (13) from body. Separate stem and thrust bearing.

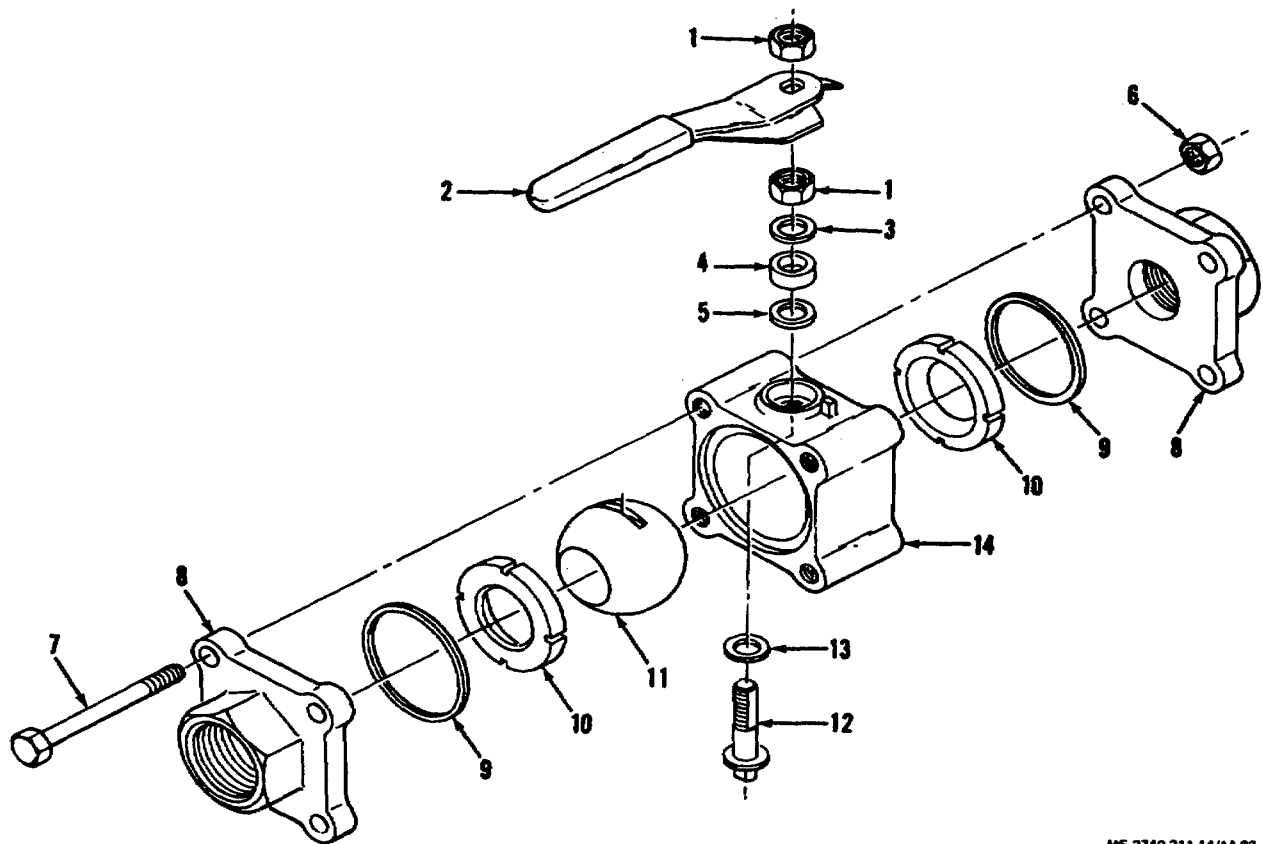

ME 3740-211-14/11-23

1. Nut (2 reqd)
2. Handle
3. Bell washer
4. Follower

5. Stem seal
6. Nut (4 reqd)
7. Bolt (4 reqd)
8. Valve end (2 reqd)

9. Body seal (2 reqd)
10. Seat (2 reqd)
11. Ball
12. stem

13. Thrust bearing
14. Body

Figure 11-23. Ball shutoff valve -- exploded view.

(2) Cleaning and inspection.

(a) Each time ball valve is disassembled for repair, discard stem seal (5), body seals (9), two seats (10), and thrust bearing (13). Replace with new items.

(b) Clean all portions of the ball valve thoroughly to remove spray fluid residue, dirt, lubricants, and contaminants.

(c) Inspect condition of all parts, and replace any part not considered serviceable. Make the following specific checks: 1. Check threaded parts for crossed or otherwise damaged threads.

2. Check condition of all parts to ensure proper function.

(3) Repair and assembly (fig. 11-23).

(a) Repair of the ball valve consists of replacing any parts not considered serviceable. Assemble the ball valve using figure 11-23 and the following steps as a guide:

1. Install thrust bearing (13) on stem (12). Insert threaded end of stem into body (14) and through mating hole. Hold stem in position and insert ball (11) into valve body. Align slot on ball to engage stem (12).

2. Place new seats (10)in valve body so that concave surfaces are against ball (11).

3. Install new body seals (9) in body and against seats (10).

4. Hold installed parts in position in body while placing valve ends (8) on two sides of body.

5. Secure assembled valve parts with four bolts (7), through valve ends (8) and body (14), and nuts (6).

6. Place new stem seal (5), follower

(4), and bell washer (3) over stem. Seat stem seal by pressing on parts. Secure parts in place with one nut (1). Tighten snugly.

7. Place valve handle (2) over stem.

With ball in open position (hole in-line with valve ports), handle must point toward valve ends (8).

Secure handle with second nut (1). Tighten snugly.

(b) Test valve for actuation by opening and closing handle. Valve shall operate smoothly and positively.

CHAPTER 12
ADMINISTRATIVE STORAGE AND INSTRUCTIONS FOR DESTRUCTION
OF MATERIEL TO PREVENT ENEMY USE

Section I. ADMINISTRATIVE STORAGE

Refer to technical manual TM 740-90-1 for information regarding administrative storage applicable to the aircraft-mounted insecticide sprayer.

Section II. DESTRUCTION OF MATERIEL TO PREVENT ENEMY USE

Refer to technical manual TM 750-244-3, dated 23 September 1969, for instructions regarding destruction of Army materiel to prevent enemy use.

APPENDIX A REFERENCES

A-1. Painting

TM 9-213

Painting instructions for Field Use

A-2. Radio Suppression

TM 11-483

Radio Interference Suppression

A-3. Maintenance

TM 38-750

TM 5-3740-211-24P

The Army Maintenance Management Systems
Repair Parts and Special Tools List

A-4. Shipment and Storage

TB 740-97-2

for Shipment and Storage

TM 740-90-1

Preservation of USAMEC Mechanical Equipment

Administrative Storage of Equipment

A-5. Destruction to Prevent Enemy Use

TM 750-244-3

Procedures for Destruction of Equipment to Prevent
Enemy Use

**APPENDIX B
MAINTENANCE ALLOCATION CHART**

Section I. INTRODUCTION

B-1. General

a. Section I provides a general explanation of all maintenance and repair functions authorized at various maintenance levels.

b. Section II designates overall responsibility for the performance of maintenance operations on the identified end item or component. The implementation of the maintenance tasks upon the end item or component will be consistent with the assigned maintenance operations.

c. Section III-special tool and test equipment requirements, (not applicable) and Section IV-supplemental instructions, explanatory notes, and/or illustrations required for a particular maintenance function, are not required for the aircraft-mounted insecticide sprayer.

B-2. Explanation of Columns in Section II

a. Group Number. The functional group is a numerical group set up on a functional basis. The applicable functional grouping indexes (obtained from TB 750-93-1 Functional Grouping Codes) are listed on the MAC in the appropriate numerical sequence. These indexes are normally set up in accordance with their function and proximity to each other.

b. Assembly Group. This column contains a brief description of the components of each functional group.

c. Maintenance Functions. This column lists the various maintenance operations ("A" through "K") and indicates the lowest maintenance level authorized to perform these operations. The symbol designations for the various maintenance levels are as follows:

- C - Operator or crew
- O - Organizational maintenance
- F - Direct support maintenance
- H - General support maintenance

The Maintenance operations are defined as follows:

A - INSPECT: Verify serviceability and detect incipient electrical or mechanical failure by close visual examination.

B TEST: Verify serviceability and detect incipient electrical or mechanical failure by measuring the mechanical or electrical characteristics of the item and comparing those characteristics with authorized standards. Tests will be made commensurate with test procedures and with calibrated tools and/or test equipment referenced in the MAC.

C SERVICE: Operations required periodically to keep the item in proper operating condition, i.e., to clean, preserve, drain, paint, and replenish fuel, lubricants, hydraulic, and deicing fluids, or compressed air supplies.

D ADJUST: Regulate periodically to prevent malfunction. Adjustments will be made commensurate with adjustment procedures and associated equipment specifications.

E ALIGN: Adjust two or more components of an electrical or mechanical system so that their functions are properly synchronized or adjusted.

F CALIBRATE: Determine, check, or rectify the graduation of an instrument, weapon, or weapons system or components of a weapons system.

GINSTALL: To set up for use in an operational environment such as an emplacement, site, or vehicle.

H REPLACE: Substitute serviceable components, assemblies, and subassemblies for unserviceable counterparts or remove and install the same item when required for the performance of other maintenance operations.

I REPAIR: Restore to a serviceable condition by replacing unserviceable parts or by any other action required using available tools, equipment, and skills-to include welding, grinding, riveting, straightening, adjusting, and facing.

J OVERHAUL: Restore an item to a completely serviceable condition (as prescribed by serviceability standards developed and published by the commodity commands) by employing techniques of "Inspect and Repair Only as Necessary" (IROAN). Maximum use of diagnostic and test equipment is combined with minimum disassembly during overhaul. "Overhaul" may be assigned to any level of maintenance except organizational, provided the time, tools, equipment, repair parts authorization, and technical skills are available at that level.

Normally, overhaul as applied to end items, is limited to depot maintenance level.

K REBUILD. Restore to a condition comparable to new by disassembling to determine the condition of each component part and reassembling using serviceable, rebuilt, or new assemblies, subassemblies, and parts.

d. Tools and Equipment, and Remarks. These columns, numbered (4) and (5), are provided for referencing the Special Tool and Test Equipment Requirements (sec. III) and Remarks (sec. IV) that may be associated with maintenance operations (sec. II).

SECTION II. MAINTENANCE ALLOCATION CHART

(1) Group No.	(2) Functional Group	(3) Maintenance functions											(4) Tools and equipment	(5) Remarks			
		A	B	C	D	E	F	G	H	I	J	K					
		Inspect	Test	Service	Adjust	Align	Calibrate	Install	Replace	Repair	Overhaul	Rebuild					
01	FRAME ASSEMBLY																
	Tank Support	C											F	F			
	Tank Straps, Cables, Struts & Tiedown Lugs.....	C			O								O	F			
02	TANK, HOSES, COUPLINGS AND STRAINERS																
	Tank	C		O									F	F			
	Hoses	C											O	F			
	Couplings	C											O	F			
	Strainers			O									O				
	Valves.....			O									F	F			
03	BOOM SPRAY SYSTEM																
	Spray Booms	C			O							O		F			
	Nozzles	C											O				
	Tee Boom												F				
	Tee Boom Strainer	O		O									F				
04	PUMP ASSEMBLY																
	Pump.....	C											F	F			
	Impeller												F				
	Bearings												F				
	Shafts												F				
	Brake Assy												F				
	Drum, Brake													F			
	Shoe, Brake												F				
	Cable Brake				O								O				
	Windmill Assy												O	O			
	Blade, Propeller	C			O								O				
	Hub & Actuator												O	F			
05	CONTROL SYSTEM																
	Support Assy				O								F	F			
	Levers.....				O								O				
	Rods, Connecting				O								O				
	Gage, Pressure												O				
	Plates, Instruction												O				
06	GROUND LOADING UNIT																
	Engine Assy	C		C	O							O	F	H			
	.. Head, Gaskets & Valves												F				
	Pistons, Rings & Crankshaft	F											F				
	Point, Set, Ignition	F			F								F				
	Plug, Spark	O			O								O				
	Cable, Ignition	C											F				
	Carburetor			O	O								F				
	Starter, Recoil				F								F	F			
	Pump Assembly	C										O	F				
	Impeller				F								F				
	Bearing & Shaft.....												F				
	Seals & Gaskets												F				
	Hose, Couplings and Strainers	C										O	F				

APPENDIX C
BASIC ISSUE ITEMS LIST AND MAINTENANCE AND OPERATING SUPPLIES

Section I. INTRODUCTION

C-1. Scope

This appendix lists items which accompany the aircraft-mounted insecticide sprayer or are required for installation, operation, or maintenance.

Section II lists the accessories, tools and publications required for the maintenance and operation, initially issued or authorized with the equipment.

Section III lists the maintenance and operating supplies required for initial operation.

C-2. Explanation of Columns

The following provides an explanation of columns in the tabular list in section II:

a. Source, Maintenance, and Recoverability Codes (Column (1)).

(1) Source code, column 1a, indicates the selection status and source for the listed item.

Source Codes are:

Code Explanation

P Applies to repair parts which are stocked in or supplied from the GSA/DSA Army supply system, and authorized for use at indicated maintenance categories.

M Applied to repair parts which are not procured or stocked but are to be manufactured at indicated maintenance categories.

X2 Applied to repair parts which are not stocked. The indicated maintenance category requiring such repair parts will attempt to obtain them through cannibalization. If not obtainable through cannibalization, such repair parts will be requisitioned with supporting justification through normal supply channels.

(2) Maintenance code, column 1b, indicates the lowest category of maintenance authorized to install the listed item. The maintenance level codes are:

Code Explanation

C Operator or crew

O Organizational maintenance

F Direct support maintenance

H General support maintenance

(3) Recoverability code, column 1c, indicates whether unserviceable items should be returned for recovery or salvage. Items not coded are expendable. Recoverability codes are:

Code Explanation

R Applied to repair parts and assemblies which are economically repairable at DSU and GSU activities and are normally furnished by supply on an exchange basis.

Code Explanation

T Applied to high dollar value recoverable parts which are subject to special handling and are issued on an exchange basis. Such repair parts are normally repaired or overhauled at depot maintenance activities.

U Applied to repair parts specifically selected for salvage by reclamation units because of precious metal content, critical materials, high dollar value reusable casings and castings, etc.

b. Federal Stock Number (col. (2)). Indicates the Federal Stock Number for the item.

c. Description (col. (3)). Indicates the Federal Item Name and any additional description required. A five-digit manufacturer's or other service code is shown in parentheses followed by the manufacturer's part number. Repair parts quantities included in kits, sets, and assemblies that differ from the actual quantity used in the specific item are listed in parentheses following the repair part name.

d. Unit of Issue (col. (4)). Indicates the unit used as a basis for issue, e.g., ea, pr, ft, yd, etc.

e. Quantity Authorized (col. (5)). Indicates the total quantity of an item required to be on hand and necessary for operation and maintenance of the equipment. Items to be requisitioned as required are indicated by an asterisk.

f. Illustration (col. (6)).

(1) Figure number, column 6a, indicates the figure number of the illustration in which the item is shown.

(2) Item number, column 6b, indicates the callout number used to reference the item in the illustration.

C-3. Explanation of Columns Contained in Section III

a. Item. This column contains numerical sequence item numbers assigned to each component application to facilitate reference.

b. Component Application. This column identifies the component application of each maintenance or operating supply item.

c. Federal Stock Number. The Federal Stock Number will be shown in this column and will be used for requisitioning purposes.

d. Description. The item and a brief description are shown.

e. Quantity Required for Initial Operation. This column lists the quantity of each maintenance item.

nance or operating supply item required for initial operation of the equipment.
 f. Quantity Required for 8 Hours Operation.
 Quantities listed represent the estimated requirements for an average eight hours of operation.

C-4. Federal Supply Code/Manufacturer

Federal Supply Code Manufacturer
 22065 Agrinautics
 29201 Homelite Division of Textron, Inc.
 78357 Snap-Tite, Inc.
 98991 Worcester Valve Co., Inc.

Section II. BASIC ISSUE ITEMS LIST

(1) Source codes			(2) Federal stock number	(3) Description	(4) Unit of Issue	(5) Quantity Auth	(6) Illustration	
(a) Source	(b) Main tenance	(c) Recover ability					(a) Figure	(b) Item

Group 31 -- Basic Issue Items, Manufacturer installed 3100 -- Basic Issue Items Manufacturer or depot installed
 Group 312 -- Basic Issue Items, Manufacturer installed 3100 -- Basic Issue Items Manufacturer or depot installed
 None
 Group 32 - Basic Issue Items, Troop Installed
 3200 - Basic Issue Items
 Troop installed or authorized
 None

Section III. MAINTENANCE AND OPERATING SUPPLIES

Item (1)	Component Application	Federal stock number	Description	Quantity required for initial operation	Quantity required for 8-hours operation	Notes
	0101-Crankcase		Oil Lubricating 1 qt. can as follows: OE-30 (sae-30)	1/4 pint		(1) includes quantity of oil to be mixed with fuel system as follow: ¼ pint or (4) oz. To 1 gal. Of gasoline. See FSC C9100-IL addition data for requisitioning procedures
	0306-Fuel Tank	9131-160-11818	Fuel, gasoline Bulk as follows Gasoline: 91A	18 ounces		(2) tank capacity Average fuel consumption is 1/100 gal. Per hour of continuous operation

INDEX

	Paragraph	Page
A		
Administrative storage	12-1	12-1
Alteration of spray pattern.....	A-5	A-1
Applicable publications	A-1	A-1
Assembly procedures (see specific component)		
B		
Ball shutoff valve	11-12	11-19
Basic issue items	3-1, C1	3-1, C-1
Boom, center		
Maintenance	4-21	4-23
Removal and installation.....	5-13	5-4
Boom, spray		
Maintenance and adjustment.....	4-20	4-22
Removal.....	6-2	6-1
Disassembly	6-3	6-1
Cleaning.....	6-4	6-4
Inspection	6-5	6-4
Assembly	6-6	6-4
Brake assembly		
Removal.....	7-8	7-3
Cleaning, inspection, repair.....	7-9	7-5
Assembly	7-10	7-5
Brake cable, pump	4-22	4-23
Bypass valve		
Maintenance and adjustment.....	4-19	4-22
Removal.....	5-18,8-2	5-4, 8-1
Disassembly	8-3	8-1
Cleaning, inspection, repair.....	8-4	8-4
Assembly	8-5	8-4
C		
Cable, pump brake	4-22	4-23
Carburetor chamber group	11-12	11-25
Carburetor repair	11-13	11-29
Center boom		
Maintenance	4-21	4-23
Removal and installation	6-13	5-4
Cleaning	3-7	31
Components, removal of		
Insecticide sprayer.....	5-5	5-1
Liquid loading system.....	11-12	11-19
Control panel		
Maintenance and adjustment	4-24	4-25
Removal.....	517,10-2	5-6,10-1
Disassembly	4-24,103	4-25,10-1
Cleaning.....	4-24,10-4	4-28,10-1
Inspection	4-24,10- 5	4-28,10-1
Assembly	10-7	10-1
Installation.....	5-17,10-8	5-6,10-1
Controls and instruments.....	2-3	2-2
Control valve		
Maintenance and adjustment	4-18	4-22
Removal and installation	5-9	5-3
Conversion of equipment	4-5	4-11
D		
Description	1-4	1-1
Destruction to prevent enemy use	12-2	12-1
Differences between models.....	1-5	1-5
Dismantling for movement.....	4-6	414
Drip pan	5-7	5-2
Dust cap	4-16	4-21
E		
Engine repair.....	11-12	11-19
Equipment conversion	4-5	4-11

	F	Paragraph	Page
Flow control valve			
Removal.....		8-2	8-1
Disassembly		8-3	8-1
Cleaning, inspection, repair.....		8-4	8-4
Assembly		8-5	8-4
Forms and records		1-2	1-1
	G		
Gage, liquid level.....		5-14	5-5
	H		
Hoses, insecticide sprayer.....		4-15, 5-6	4-21, 5-1
	I		
Identification and tabulated data		1-6	1-5
Ignition parts, liquid loading system		11-12, 11-13	11-24
In flight checkout.....		2-7	2-4
Insecticide sprayer			
Assembly		4-2	4-3
Installation.....		4-3	4-6
Removal from helicopter		4-4	4-10
Inspecting and servicing the equipment			
Operator.....		2-1	2-1
Organizational.....		4-1	4-1
	L		
Liquid level gage.....		5-14	5-5
Liquid loading system			
Assembly		4-2	4-6
Operator maintenance		11-5	11-5
Organizational maintenance.....		11-8	11-8
Liquid loading tube.....		5-10	5-3
Loading procedure.....		2-7	2-3
Lubrication			
Insecticide sprayer		3-3	3-1
Liquid loading system.....		11-3	11-5
	M		
Maintenance allocation chart.....		B-1	B-1
Manual control panel		4-24	4-25
Movement to a new worksite			
Dismantling		4-6	4-14
Reinstallation		4-7	4-14
	O		
Operation under unusual conditions			
General.....		2-8	2-5
Procedures in cold weather.....		2-9	2-5
Procedures in dusty areas		2-9	2-5
Procedures in extreme heat.....		2-9	2-5
Procedures in freezing weather.....		2-9	2-5
Procedures in high altitudes.....		2-9	2-5
Procedures in salt water areas.....		2-9	2-5
Operation under usual conditions			
General.....			2-4
Starting		2-5	2-2
Operation.....		2-7	2-3
Stopping.....		2-6	2-3
Post flight operation		2-7	2-4
	P		
Preventive maintenance checks and services			
Insecticide sprayer			
Operator.....		3-5	3-1
Organizational.....		4-12	4-15
Liquid loading system			
Operator.....		11-4	11-5
Organizational.....		11-7	11-8
Pump and brake assembly		5-8	5-2
Pump assembly			
Removal.....		5-8, 7-12	5-2, 7-5
Disassembly		7-13	7-5

P - Continued

	Paragraph	Page
Cleaning, inspection, repair.....	7-14	7-7
Assembly.....	7-15	7-7
Installation.....	5,8, 7-16	5-2, 7-8
Pump brake cable.....	4-22	4-23
Pump inlet tube.....	5-11	5-3
Pump, liquid loading system.....	11-12	11-23
R		
Reinstallation after movement.....	4-7	4-14
Removal of components		
Insecticide sprayer.....	5-5	5-1
Liquid loading system.....	11-12	11-19
Removal from helicopter 4-4 4-10		
Repair and replacement standards.....	11-9	11-13
Repair parts and special tools list.....	3-2	3-1
Reporting of errors.....	1-3	1-1
Reporting of errors.....	1-3	1-1
S		
Scope.....	1-1	1-1
Service upon receipt of materiel		
Operator.....	3-1	3-1
Organizational.....	4-1	4-1
Special tools and equipment		
Insecticide sprayer.....	4-9, -2	4-15, 5-1
Liquid loading system.....	11-6, 11-10	11-7, 11-13
Spray boom		
Maintenance and adjustment.....	4-20	4-22
Removal.....	6-2	6-1
Disassembly.....	6-3	6-1
Cleaning.....	6-4	6-4
Inspection.....	6-5	6-4
Assembly.....	6-6	6-4
Spray pattern, alteration.....	4-5	4-11
Starter fan housing repair.....	1 11-13	11-26
Starting the equipment.....	2-5	2-2
Stopping the equipment.....	2-6	2-3
Strainer.....	4-17	4-21
Sump.....	5-15	5-5
Synchromatic windmill assembly		
Maintenance and adjustment.....	4-23	4-24
Removal.....	7-2	7-1
Disassembly.....	7-3	7-1
Cleaning, inspection, repair.....	7-4	7-3
Assembly.....	7-5	7-3
Installation.....	7-6	7-3
T		
Tabulated data		
Insecticide sprayer.....	1-6	1-5
Liquid loading system.....	11-1	11-1
Tank assembly		
Maintenance and adjustment.....	4-14	4-16
Removal.....	5-16, 8-10	5-5, 8-6
Disassembly.....	8-11	8-6
Cleaning, inspection, repair.....	8-12	8-6
Assembly.....	8-13	8-6
Installation.....	5-16, 8-14	5-6, 8-6
Tank straps, struts and tiedown lugs		
Removal.....	9-6	9-2
Cleaning, inspection, repair.....	9-7	9-2
Installation.....	9-8	9-2
Tank support assembly		
Disassembly.....	9-2	9-1
Cleaning, inspection, repair.....	9-3	9-1
Installation.....	9-4	9-2
Tools and equipment.....	4-8, 5-1	4-15, 5-1
Troubleshooting chart		
Insecticide sprayer		
Operator.....	3-6	3-1

	Paragraph	Page
T - Continued		
Organizational.....	4-13	4-15
Direct and general support.....	5-4	5-1
Liquid loading system		
Operator.....	11-4	11-5
Organizational.....	11-7	11-8
Direct and general support.....	11-11	11-19
Tube, liquid loading.....	5-10	5-3
Tube, pump inlet.....	5-11	5-3
V		
Valve, ball shutoff.....	11-12	11-9
Valve, bypass		
Maintenance and adjustment.....	4-19	4-22
Removal.....	5-12, 8-2	5-4, 8-1
Disassembly.....	8-3	8-1
Cleaning, inspection, repair.....	8-4	8-4
Assembly.....	8-5	8-4
Valve, control		
Maintenance and adjustment.....	4-18	4-22
Removal and installation.....	5-9	5-3
Valved nipple.....	4-16	4-21
Valved quick-disconnect coupling		
General.....		8-6 8-5
Removal.....	8-7	8-5
Cleaning and inspection.....	8-8	8-5
Valves, fuel control and bypass		
Removal.....	8-2	8-1
Disassembly.....	8-3	8-1
Cleaning, inspection, repair.....	8-4	8-4
Assembly.....	8-5	8-4
W		
Windmill assembly, synchromatic		
Adjustment of blade angle.....	4-5	4-12
Maintenance and adjustment.....	4-23	4-24
Removal.....	7-2	7-1
Disassembly.....	7-1	7-3
Cleaning, inspection, repair.....	7-4	7-3
Assembly.....	7-5	7-3
Installation.....	7-6	7-3

By Order of the Secretary of the Army:

Official:

VERNE L. BOWERS
*Major General, United States Army,
The Adjutant General.*

W. C. WESTMORELAND,
*General, United States Army,
Chief of Staff.*

Distribution:

To be distributed in accordance with DA Form 12-25A, (qty rqr block No. 149) Operator maintenance requirements for Insect and Pest Control Equipment.

U.S. GOVERNMENT PRINTING OFFICE : 1985 0 - 461-202 (20237)

RECOMMENDED CHANGES TO EQUIPMENT TECHNICAL PUBLICATIONS



SOMETHING WRONG WITH THIS PUBLICATION?

THEN... JOT DOWN THE DOPE ABOUT IT ON THIS FORM, CAREFULLY TEAR IT OUT, FOLD IT AND DROP IT IN THE MAIL!

FROM: (PRINT YOUR UNIT'S COMPLETE ADDRESS)

DATE SENT

PUBLICATION NUMBER

PUBLICATION DATE

PUBLICATION TITLE

BE EXACT... PIN-POINT WHERE IT IS				IN THIS SPACE TELL WHAT IS WRONG AND WHAT SHOULD BE DONE ABOUT IT:
PAGE NO.	PARA-GRAPH	FIGURE NO.	TABLE NO.	

PRINTED NAME, GRADE OR TITLE, AND TELEPHONE NUMBER

SIGN HERE:

TEAR ALONG PERFORATED LINE

DA FORM 1 JUL 79 **2028-2**

PREVIOUS EDITIONS ARE OBSOLETE.

P.S.—IF YOUR OUTFIT WANTS TO KNOW ABOUT YOUR RECOMMENDATION MAKE A CARBON COPY OF THIS AND GIVE IT TO YOUR HEADQUARTERS.

THE METRIC SYSTEM AND EQUIVALENTS

WEIGHT MEASURE

1 Centimeter = 10 Millimeters = 0.01 Meters = 0.3937 Inches
 1 Meter = 100 Centimeters = 1000 Millimeters = 39.37 Inches
 1 Kilometer = 1000 Meters = 0.621 Miles

WEIGHTS

1 Gram = 0.001 Kilograms = 1000 Milligrams = 0.035 Ounces
 1 Kilogram = 1000 Grams = 2.2 lb.
 1 Metric Ton = 1000 Kilograms = 1 Megagram = 1.1 Short Tons

LIQUID MEASURE

1 Milliliter = 0.001 Liters = 0.0338 Fluid Ounces
 1 Liter = 1000 Milliliters = 33.82 Fluid Ounces

SQUARE MEASURE

1 Sq. Centimeter = 100 Sq. Millimeters = 0.155 Sq. Inches
 1 Sq. Meter = 10,000 Sq. Centimeters = 10.76 Sq. Feet
 1 Sq. Kilometer = 1,000,000 Sq. Meters = 0.386 Sq. Miles

CUBIC MEASURE

1 Cu. Centimeter = 1000 Cu. Millimeters = 0.06 Cu. Inches
 1 Cu. Meter = 1,000,000 Cu. Centimeters = 35.31 Cu. Feet

TEMPERATURE

$5/9(^{\circ}\text{F} - 32) = ^{\circ}\text{C}$
 212° Fahrenheit is equivalent to 100° Celsius
 90° Fahrenheit is equivalent to 32.2° Celsius
 32° Fahrenheit is equivalent to 0° Celsius
 $9/5^{\circ}\text{C} + 32 = ^{\circ}\text{F}$

APPROXIMATE CONVERSION FACTORS

TO CHANGE	TO	MULTIPLY BY
Inches	Centimeters	2.540
Feet	Meters	0.305
Yards	Meters	0.914
Miles	Kilometers	1.609
Square Inches	Square Centimeters	6.451
Square Feet	Square Meters	0.093
Square Yards	Square Meters	0.836
Square Miles	Square Kilometers	2.590
Acres	Square Hectometers	0.405
Cubic Feet	Cubic Meters	0.028
Cubic Yards	Cubic Meters	0.765
Fluid Ounces	Milliliters	29.573
its	Liters	0.473
arts	Liters	0.946
allons	Liters	3.785
Ounces	Grams	28.349
Pounds	Kilograms	0.454
Short Tons	Metric Tons	0.907
Pound-Feet	Newton-Meters	1.356
Pounds per Square Inch	Kilopascals	6.895
Miles per Gallon	Kilometers per Liter	0.425
Miles per Hour	Kilometers per Hour	1.609

TO CHANGE	TO	MULTIPLY BY
Centimeters	Inches	0.394
Meters	Feet	3.280
Meters	Yards	1.094
Kilometers	Miles	0.621
Square Centimeters	Square Inches	0.155
Square Meters	Square Feet	10.764
Square Meters	Square Yards	1.196
Square Kilometers	Square Miles	0.386
Square Hectometers	Acres	2.471
Cubic Meters	Cubic Feet	35.315
Cubic Meters	Cubic Yards	1.308
Milliliters	Fluid Ounces	0.034
Liters	Pints	2.113
Liters	Quarts	1.057
ers	Gallons	0.264
ms	Ounces	0.035
ograms	Pounds	2.205
Metric Tons	Short Tons	1.102
Newton-Meters	Pounds-Feet	0.738
Kilopascals	Pounds per Square Inch	0.145
ometers per Liter	Miles per Gallon	2.354
ometers per Hour	Miles per Hour	0.621



PIN: 005452-001